



**OPERATING INSTRUCTIONS**

## **NETWORK INTERCOM SYSTEM**

### **AN-8000 SERIES**

Thank you for purchasing AIPHONE's Network Intercom system.  
Please carefully follow the instructions in this manual to ensure long, trouble-free use of your equipment.

# TABLE OF CONTENTS

<b>SAFETY PRECAUTIONS (For AN-8000EX and AN-8000MI)</b> .....	11
<b>OPERATING INSTRUCTIONS CONFIGURATION</b> .....	13

<b>Chapter 1: GENERAL DESCRIPTION</b>
---------------------------------------

<b>1. GENERAL DESCRIPTION</b> .....	1-2
<b>2. FEATURES</b> .....	1-2
<b>3. HANDLING PRECAUTIONS</b> .....	1-2
<b>4. SPECIFICATIONS</b> .....	1-3
<b>5. SYSTEM CONFIGURATION</b>	
5.1. System Configuration Example .....	1-4
5.1.1. Exchange .....	1-5
5.1.2. Peripheral components .....	1-5
5.1.3. IP Stations .....	1-5
5.1.4. Stations .....	1-5
5.1.5. Others .....	1-5
5.2. Component Description	
5.2.1. Exchange .....	1-5
5.2.2. Peripheral components .....	1-6
5.2.3. IP Stations .....	1-6
5.2.4. Stations .....	1-7
5.2.5. Others .....	1-7
5.3. Rack Mounting Examples for Exchanges	
5.3.1. A 128-line exchange system .....	1-8
5.3.2. A 192-line exchange system .....	1-8
5.3.3. A 256-line exchange system .....	1-8
5.3.4. A 1280-line exchange system .....	1-9
<b>6. NOMENCLATURE AND FUNCTIONS</b>	
6.1. AN-8000EX IP Intercom Exchange	
[Front] .....	1-10
[Rear] .....	1-10
6.2. AN-8000MI Multi Interface Unit	
[Front] .....	1-11
[Rear] .....	1-11
6.3. AN-8500MS IP Multifunctional Master Station	
[Top] .....	1-12
[Rear] .....	1-13
[Bottom] .....	1-14
6.4. AN-8540DS IP Door Station	
[Front] .....	1-15
[Side] .....	1-15
[Rear] .....	1-15
[Top] .....	1-15

6.5. AN-8000MS Multifunctional Master Station	
[Top] .....	1-16
[Rear] .....	1-17
[Bottom] .....	1-18
6.6. AN-8010MS Standard Master Station	
[Top] .....	1-19
[Rear] .....	1-20
[Bottom] .....	1-20
6.7. AN-8011MS Standard Hands-free Master Station	
[Top] .....	1-21
[Rear] .....	1-22
[Bottom] .....	1-22
6.8. AN-8020MS Industrial-Use Master Station	
[Top] .....	1-23
[Rear] .....	1-24
[Bottom] .....	1-24
6.9. AN-8031MS Flush-Mount Master Station	
[Front] .....	1-25
[Rear] .....	1-25
6.10. AN-8050DS Door Station	
[Front] .....	1-26
[Rear] .....	1-26

## 7. SYSTEM FUNCTION TABLE

7.1. Basic Functions .....	1-27
7.2. Multi Interface Unit's Functions .....	1-30

## 8. PAGING FUNCTION OUTLINES

8.1. Paging Types	
8.1.1. PA paging .....	1-31
8.1.2. Station paging .....	1-31
8.2. Paging Functions	
8.2.1. Zone paging .....	1-32
8.2.2. Selectable paging .....	1-32
8.2.3. All-call paging .....	1-32
8.3. Station Paging Receiving Mode	
8.3.1. Conversation priority mode .....	1-32
8.3.2. Paging priority mode .....	1-32
8.4. Responding to Paging	
8.4.1. Automatic response .....	1-33
8.4.2. Zone number dialing .....	1-33

## 9. MULTI INTERFACE FUNCTION OUTLINES

9.1. External Input Paging .....	1-34
9.2. PA paging .....	1-34
9.3. PBX Interface (E and M Interface) .....	1-34
9.4. BGM .....	1-35
9.5. Contact Input and Output Functions	
9.5.1. External equipment control .....	1-36
9.5.2. Contact bridge function (external contact interlock) .....	1-36
9.5.3. Paging busy input .....	1-36

## **Chapter 2: FUNCTIONS AND OPERATION**

### **1. BASIC USAGE**

1.1. Calling from a Master Station .....	2-2
1.2. Calling from a Door Station .....	2-3
1.3. Receiving a Call	
1.3.1. Receiving a call at the master station .....	2-4
1.3.2. Receiving a call at the door station .....	2-4
1.4. Station Speaker Volume .....	2-4

### **2. CONVERSATION FUNCTIONS AND OPERATION**

2.1. Conversation	
2.1.1. Hands-free conversation .....	2-5
2.1.2. Handset conversation .....	2-5
2.1.3. PTT conversation .....	2-6
2.2. Calling	
2.2.1. Individual calls .....	2-6
2.2.2. Master station calls .....	2-6
2.2.3. Redialing .....	2-6
2.2.4. Recall .....	2-7
2.2.5. Voice callings .....	2-7
2.2.6. Group calls .....	2-8
2.3. Setting Call Receiving Modes	
2.3.1. Automatic connection .....	2-8
2.3.2. Continuous call .....	2-8
2.4. Speed Dialing	
2.4.1. Auto-dialing (AN-8000MS/8500MS only) .....	2-9
2.4.2. One-touch dialing .....	2-10
2.5. Hold	
2.5.1. Mic off .....	2-11
2.5.2. Call hold .....	2-11
2.6. Call Transfer .....	2-12
2.7. Automatic Transfer	
2.7.1. Group hunting .....	2-14
2.7.2. Absence transfer .....	2-16
2.7.3. Call forwarding .....	2-17
2.8. Remote Response .....	2-19
2.9. Executive Priority .....	2-21
2.10. Time-Out .....	2-21
2.11. Group Blocking .....	2-22

### **3. PAGING FUNCTION AND OPERATION**

3.1. Paging	
3.1.1. Zone paging .....	2-23
3.1.2. Selectable paging .....	2-24
3.1.3. All-call paging .....	2-25
3.1.4. Paging priority .....	2-25
3.2. External Input Paging (only when the AN-8000MI is used) .....	2-26
3.3. Responding to Paging	
3.3.1. Automatic response .....	2-27
3.3.2. Zone number designation response .....	2-28



## 4. OTHER FUNCTION AND OPERATION

4.1. Scan Monitor .....	2-29
4.2. PBX Connection (only when the AN-8000MI is used)	
4.2.1. Calling the PBX extension telephone .....	2-30
4.2.2. Being called from a PBX extension telephone .....	2-31
4.2.3. Being paged from a PBX extension telephone .....	2-31
4.3. BGM (only when the AN-8000MI is used) .....	2-32
4.4. External Equipment Control (only when the AN-8000MI is used) .....	2-33
4.5. Calling Station Indication/CCTV Interlock (only when the AN-8000MI is used) .....	2-35
4.6. Door Remote Control (only when the AN-8050DS/8540DS/8000MI is used) .....	2-36
4.7. Contact Bridge (only when the AN-8000MI is used) .....	2-37
4.8. Paging Busy Input (only when the AN-8000MI is used) .....	2-37

## 5. MASTER STATION OPERATION TABLE .....

2-38

## 6. MULTIFUNCTIONAL MASTER STATION'S LCD DISPLAY TABLE .....

2-39

### **Chapter 3: INSTALLATION & WIRING**

#### 1. INSTALLATION OF THE EXCHANGE

1.1. Equipment Rack Mounting	
1.1.1. Setting space .....	3-2
1.1.2. Caution when installing the unit .....	3-2
1.1.3. Exchange mounting .....	3-3
1.2. Desk-Top Installation .....	3-3
1.3. Wall Mounting .....	3-4

#### 2. INSTALLATION OF THE MULTI INTERFACE UNIT

2.1. Equipment Rack Mounting	
2.1.1. Setting space .....	3-5
2.1.2. Caution when installing the unit .....	3-5
2.1.3. AN-8000MI mounting .....	3-6
2.2. Desk-Top Installation .....	3-6
2.3. Wall Mounting .....	3-7

#### 3. INSTALLATION OF STATIONS

3.1. When Mounting the Station on a Wall	
3.1.1. AN-8000MS/8010MS/8500MS .....	3-8
3.1.2. AN-8020MS .....	3-8
3.2. On-Wall Mounting	
3.2.1. AN-8000MS/8010MS/8020MS/8500MS .....	3-9
3.2.2. AN-8011MS .....	3-11
3.3. Desk-Top Installation	
3.3.1. AN-8000MS/8010MS/8020MS/8500MS .....	3-13
3.3.2. AN-8011MS .....	3-14
3.4. In-Wall Mounting Using an Electrical Box	
3.4.1. AN-8031MS .....	3-15
3.4.2. AN-8050DS/8540DS .....	3-16
3.5. On-Wall Mounting Using a Wall-Mount Box	
3.5.1. AN-8031MS .....	3-17
3.5.2. AN-8050DS/8540DS .....	3-18

## 4. WIRING

4.1. Exchange Connection .....	3-19
4.2. Station Connection	
4.2.1. Station and Exchange connection .....	3-21
4.2.2. Headset plug connection (AN-8000MS only) .....	3-22
4.2.3. External speaker terminals and control output terminals connections .....	3-23
4.2.4. AN-8031MS and RS-191 connections .....	3-24
4.2.5. AN-8031MS and external switch connections .....	3-25
4.2.6. AN-8050DS and external relay connections .....	3-25
4.3. Multi Interface Unit Connection .....	3-26
4.4. IP Station Connection	
4.4.1. AN-8500MS connections .....	3-29
4.4.2. AN-8540DS connections .....	3-30
4.5. Type of Cable .....	3-31
4.6. Relations Between Core Diameter of Cable and Maximum Cable Length .....	3-31
4.7. Connector Connection	
4.7.1. Mini-clamp connector connection .....	3-32
4.7.2. Terminal plug connection .....	3-32
4.8. E-7000TB Terminal Board Wiring .....	3-34

### **Chapter 4: BEFORE PERFORMING SYSTEM SETTINGS...**

## 1. SYSTEM SETTING ITEMS AND DEFAULT

1.1. General System .....	4-2
1.2. Exchange	
1.2.1. Network settings .....	4-3
1.2.2. Sampling frequency correction .....	4-3
1.2.3. Function settings .....	4-4
1.3. Multi Interface Unit	
1.3.1. Network settings .....	4-5
1.3.2. Sampling frequency correction .....	4-5
1.3.3. Function settings .....	4-5
1.3.4. Audio I/O .....	4-6
1.3.5. Contact I/O .....	4-6
1.4. IP Stations	
1.4.1. Network settings .....	4-7
1.4.2. Function settings 1 .....	4-7
1.4.3. Function settings 2 .....	4-8
1.4.4. Speed dialing .....	4-8
1.4.5. Scan monitor .....	4-9
1.5. Stations	
1.5.1. Function settings .....	4-9
1.5.2. Speed dialing .....	4-10
1.5.3. Scan monitor .....	4-10
1.5.4. Paging .....	4-10
1.5.5. Group .....	4-10

## 2. TURNING THE SYSTEM'S POWER SWITCH ON

2.1. Caution When Turning the Power Switch On .....	4-11
2.2. Turning the Power Switch On .....	4-11

## 3. SETTING PROCEDURES .....

4-11

**4. NETWORK SETTINGS USING A PERSONAL COMPUTER ..... 4-12**

**Chapter 5: SYSTEM SETTINGS BY SOFTWARE**

**1. AN-8000 SOFTWARE GENERAL DESCRIPTION**

1.1. General Description ..... 5-2

    1.1.1. Equipment scan and network setting functions ..... 5-2

    1.1.2. System setting function ..... 5-2

1.2. PC Network Settings ..... 5-2

1.3. Notes on Setting Update ..... 5-2

**2. INSTALLING SOFTWARE**

2.1. System Requirements ..... 5-3

2.2. Activating the Setup Guide ..... 5-3

2.3. AN-8000 Software Installation

    2.3.1. Installation ..... 5-4

    2.3.2. Version update information ..... 5-5

    2.3.3. Install folder configuration ..... 5-6

2.4. AN-8000 Software Uninstallation ..... 5-6

**3. ACTIVATING AN-8000 SOFTWARE PROGRAM ..... 5-7**

**4. UNIT SCAN (NETWORK SETTINGS)**

4.1. Screen Description ..... 5-9

4.2. Menu

    4.2.1. File ..... 5-10

    4.2.2. Scan ..... 5-10

    4.2.3. Help ..... 5-10

4.3. Buttons ..... 5-10

4.4. Using Unit Scan ..... 5-11

4.5. Changing Equipment Settings ..... 5-12

4.6. Automatic IP Address Assignment ..... 5-12

4.7. Subnet Mask and Default Gateway Settings ..... 5-13

**5. SYSTEM SETTING FUNCTION**

5.1. Screen Description ..... 5-15

5.2. Menu

    5.2.1. File ..... 5-16

    5.2.2. Setting ..... 5-16

    5.2.3. Help ..... 5-16

5.3. Overall System Configuration Settings

    5.3.1. Equipment registration ..... 5-17

    5.3.2. Station number and type settings ..... 5-20

    5.3.3. Network communications registration ..... 5-22

    5.3.4. Multicast communications registration ..... 5-23

5.4. Exchange Settings

    5.4.1. Network settings ..... 5-24

    5.4.2. Sampling frequency correction settings ..... 5-28

    5.4.3. Function settings ..... 5-29

5.5. Multi Interface Unit Settings

    5.5.1. Network settings ..... 5-31

    5.5.2. Sampling frequency correction settings ..... 5-35

5.5.3. Function settings .....	5-36
5.5.4. Audio I/O settings .....	5-38
5.5.5. Contact setting .....	5-40
5.6. Setting IP Stations	
5.6.1. Network settings .....	5-42
5.6.2. Function settings .....	5-46
5.6.3. Speed dialing settings .....	5-50
5.6.4. Scan Monitor settings (IP master station only) .....	5-51
5.7. Setting Stations Connected to the Exchange	
5.7.1. Function settings .....	5-52
5.7.2. Speed dialing settings .....	5-55
5.7.3. Scan Monitor settings .....	5-56
5.8. Paging Zone Settings .....	5-57
5.9. Group Settings	
5.9.1. Group blocking settings .....	5-58
5.9.2. Remote response group settings .....	5-60
<b>6. WHEN SETTINGS ARE COMPLETED</b>	
6.1. Saving Setting Contents to Files .....	5-62
6.2. Uploading Settings .....	5-62
6.3. Downloading Settings .....	5-62
<b>7. CHANGING THE PASSWORD</b>	
7.1. Changing the System Password .....	5-63
7.2. Changing the Station Maintenance Password .....	5-64
<b>8. SYSTEM CLOCK SETTINGS</b> .....	5-65

<b><i>Chapter 6: SYSTEM SETTINGS USING THE BROWSER</i></b>
--

<b>1. OUTLINE OF SETTINGS USING BROWSER</b> .....	6-2
<b>2. MENU ITEMS</b> .....	6-2
<b>3. DISPLAYING THE MENU SCREEN</b> .....	6-3
<b>4. NETWORK SETTING</b> .....	6-5
<b>5. OPERATION STATUS DISPLAY</b>	
5.1. AN-8000EX .....	6-6
5.2. AN-8000MI .....	6-7
5.3. AN-8500MS .....	6-9
5.4. AN-8540DS .....	6-11
<b>6. LINE STATUS INDICATION (Only for the Exchange)</b> .....	6-12
<b>7. NETWORK STATUS INDICATION</b> .....	6-14
<b>8. OPERATION LOG</b> .....	6-15
<b>9. STREAM LOG</b> .....	6-17
<b>10. SYSTEM MANAGEMENT</b> .....	6-20
10.1. Changing System Names and Passwords .....	6-22
10.2. Uploading Setting File .....	6-22

10.3. Downloading Setting File .....	6-23
10.4. Updating Firmware .....	6-24
10.5. Clock Settings .....	6-25

<b>Chapter 7: MULTIFUNCTIONAL STATION MENU SCREEN OPERATION (AN-8000MS/8500MS ONLY)</b>
---

<b>1. KEYS USED FOR MENU SCREEN OPERATION .....</b>	<b>7-2</b>
<b>2. MENU ITEMS .....</b>	<b>7-2</b>
<b>3. MONITORING LINE STATUS .....</b>	<b>7-3</b>
<b>4. UPDATING LOG FILES .....</b>	<b>7-3</b>
<b>5. CONFIRMING THE SET SOUND VOLUME (AN-8500MS ONLY) .....</b>	<b>7-4</b>
<b>6. SYSTEM SETTINGS</b>	
6.1. Entering Maintenance Screen .....	7-4
6.2. Network Settings .....	7-5
6.3. Station Number Settings .....	7-6
6.4. System Clock Settings .....	7-7
6.5. Restarting the Exchange .....	7-8

<b>Chapter 8: APPENDIX</b>
----------------------------

<b>1. BASIC KNOWLEDGE ABOUT NETWORKS</b>	
1.1. IP Networks and Address .....	8-2
1.2. Network Address Port Translation (NAPT, IP Masquerade) and AN-8000 Software Program .....	8-3
1.3. Unicast vs. Multicast Communications .....	8-4
1.4. Network Paging Restrictions .....	8-4
1.5. Unit Scan and Broadcast Communications Domains .....	8-5
1.6. Sampling Frequency Correction (AN-8000EX/8000MI only) .....	8-5
<b>2. IF TROUBLE OCCURS: .....</b>	<b>8-6</b>
<b>3. INDICATOR STATUS &amp; TROUBLESHOOTING .....</b>	<b>8-8</b>
<b>4. SPECIFICATIONS</b>	
4.1. AN-8000EX IP Intercom Exchange .....	8-9
4.2. AN-8000MI Multi Interface Unit .....	8-10
4.3. AN-8500MS IP Multifunctional Master Station .....	8-11
4.4. AN-8540DS IP Door Station .....	8-12
4.5. AN-8000MS Multifunctional Master Station .....	8-13
4.6. AN-8010MS Standard Master Station .....	8-14
4.7. AN-8011MS Standard Hands-Free Master Station .....	8-15
4.8. AN-8020MS Industrial-Use Master Station .....	8-16
4.9. AN-8031MS Flush-Mount Master Station .....	8-17
4.10. AN-8050DS Door Station .....	8-18
4.11. YC-280 Wall Mounting Bracket .....	8-18
4.12. YC-290 Wall Mounting Bracket .....	8-19

4.13. YC-241 Back Box .....	8-19
4.14. YC-251 Wall-Mount Box .....	8-19
4.15. YC-150 Back Box .....	8-19
4.16. YS-13A Wall-Mount Box .....	8-20
4.17. E-7000TB Terminal Board .....	8-20
4.18. RS-191 Option Handset .....	8-20
4.19. AD-1210P AC Adapter .....	8-21

## SAFETY PRECAUTIONS (For AN-8000EX/8000MI)

- Before installation or use, be sure to carefully read all the instructions in this section for correct and safe operation.
- Be sure to follow all the precautionary instructions in this section, which contain important warnings and/or cautions regarding safety.
- After reading, keep this manual handy for future reference.

### Safety Symbol and Message Conventions

Safety symbols and messages described below are used in this manual to prevent bodily injury and property damage which could result from mishandling. Before operating your product, read this manual first and understand the safety symbols and messages so you are thoroughly aware of the potential safety hazards.



### WARNING

Indicates a potentially hazardous situation which, if mishandled, could result in death or serious personal injury.



### CAUTION

Indicates a potentially hazardous situation which, if mishandled, could result in moderate or minor personal injury, and/or property damage.



### WARNING

#### When Installing the Unit

- Do not expose the unit to rain or an environment where it may be splashed by water or other liquids, as doing so may result in fire or electric shock.
- Use the unit only with the voltage specified on the unit. Using a voltage higher than that which is specified may result in fire or electric shock.
- Do not cut, kink, otherwise damage nor modify the power supply cord. In addition, avoid using the power cord in close proximity to heaters, and never place heavy objects -- including the unit itself -- on the power cord, as doing so may result in fire or electric shock.
- Avoid installing or mounting the unit in unstable locations, such as on a rickety table or a slanted surface. Doing so may result in the unit falling down and causing personal injury and/or property damage.
- Install the unit only in a location that can structurally support the weight of the unit and the mounting bracket. Doing otherwise may result in the unit falling down and causing personal injury and/or property damage.

#### When the Unit is in Use

- Should the following irregularity be found during use, immediately disconnect the power supply plug from the AC outlet and contact your nearest AIPHONE sales office. Make no further attempt to operate the unit in this condition as this may cause fire or electric shock.

- If you detect smoke or a strange smell coming from the unit.
- If water or any metallic object gets into the unit
- If the unit falls, or the unit case breaks
- If the power supply cord is damaged (exposure of the core, disconnection, etc.)
- If it is malfunctioning (no tone sounds.)
- To prevent a fire or electric shock, never open nor remove the unit case as there are high voltage components inside the unit. Refer all servicing to your nearest AIPHONE sales office.
- Do not insert nor drop metallic objects or flammable materials in the ventilation slots of the unit's cover, as this may result in fire or electric shock.
- Do not touch a plug during thunder and lightning, as this may result in electric shock.



### CAUTION

#### When Installing the Unit

- Never plug in nor remove the power supply plug with wet hands, as doing so may cause electric shock.
- When unplugging the power supply cord, be sure to grasp the power supply plug; never pull on the cord itself. Operating the unit with a damaged power supply cord may cause a fire or electric shock.
- Do not block the ventilation slots in the unit's cover or fan exhaust vent. Doing so may cause heat to build up inside the unit and result in fire.

- Be sure to follow the instructions below when rack-mounting the unit. Failure to do so may cause a fire or personal injury.
  - Install the equipment rack on a stable, hard floor. Fix it with anchor bolts or take other arrangements to prevent it from falling down.
  - To mount the unit on the equipment rack CR-273 or CR-413, use the rack mounting hardware supplied with the unit.
  - When connecting the unit's power cord to an AC outlet, use the AC outlet with current capacity allowable to the unit.

#### **When the Unit is in Use**

- Do not place heavy objects on the unit as this may cause it to fall or break which may result in personal injury and/or property damage. In addition, the object itself may fall off and cause injury and/or damage.
- Do not stand or sit on, nor hang down from the unit as this may cause it to fall down or drop, resulting in personal injury and/or property damage.



# OPERATING INSTRUCTIONS CONFIGURATION

This operating instruction consists of Chapter 1 – 8 as follows.  
Please read the necessary chapter as required.

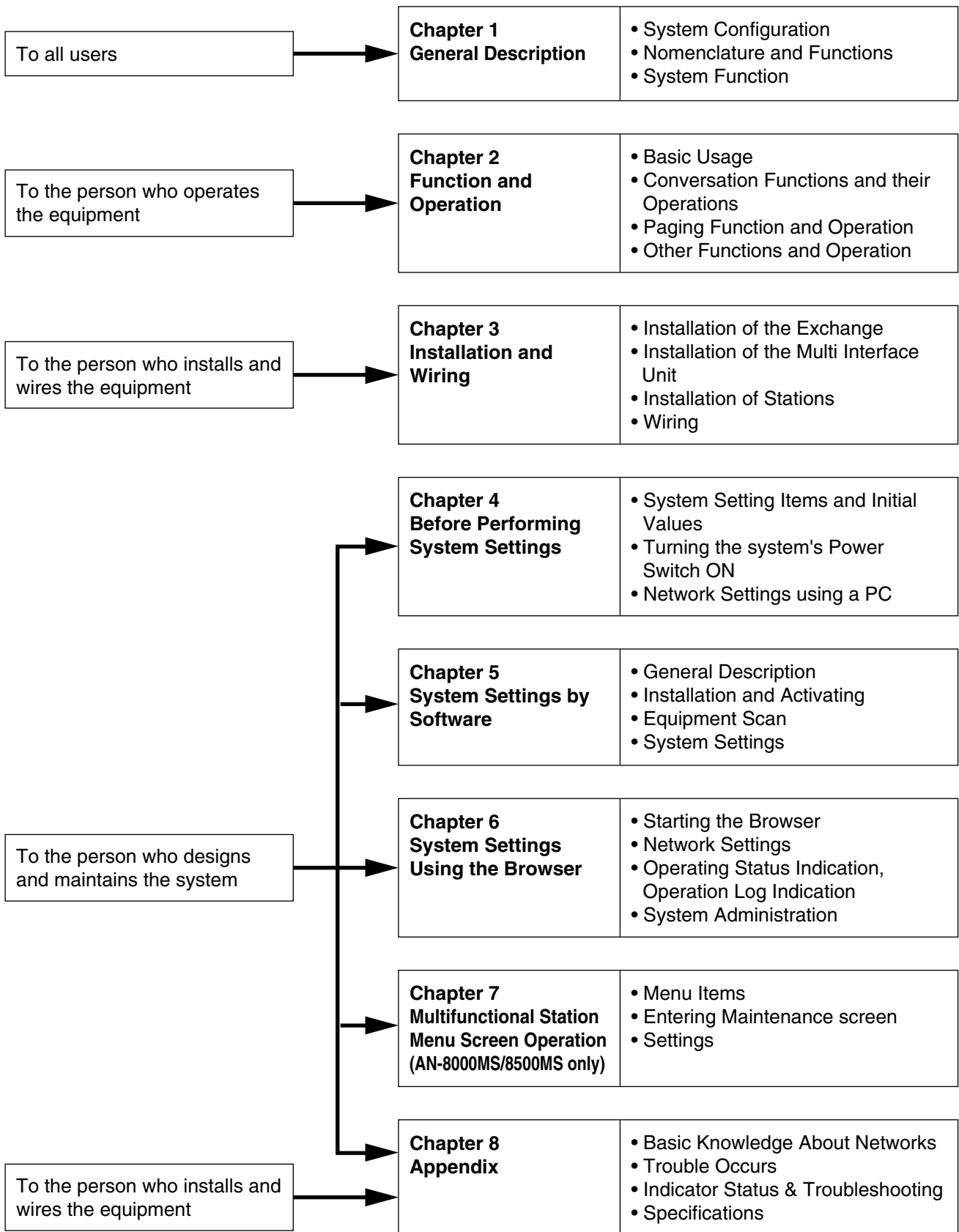

# ***Chapter 1***

---

## ***GENERAL DESCRIPTION***

This chapter describes the Exchange, Multi interface unit and IP station system configurations, station types, and functions of the AN-8000 Series Network Intercom System.

## 1. GENERAL DESCRIPTION

The AN-8000 Series is a network intercom system (IP network compatible intercom) employing packet audio technology\*<sup>1</sup>. By connecting IP intercom exchanges (which can connect up to 16 stations per exchange), Multi interface units, and IP stations to a network (LAN or WAN\*<sup>2</sup>), an optimal system can be constructed for in-house or wide area information communications such as duplex conversations between stations, periodical broadcasts, and BGM broadcasts. Since up to 80 exchanges, multi interface units and IP stations can be combined, systems of up to a total of 1,280 stations can be realized. The system's "echo cancellation"\*<sup>3</sup> feature makes hands-free duplex conversation possible (conversations made without using a handset at both parties) between stations. In addition, the multi interface unit features a contact bridge function to be performed by way of contact input and output control.

\*<sup>1</sup> Technology related to audio transmission over a network.

\*<sup>2</sup> The fixed global IP address must be assigned to the units connected via the Internet.

\*<sup>3</sup> A circuit that prevents acoustic feedback or echo generated when the voice output from the station's internal speaker enters the microphone.

### Warning

This is a Class A product. In a domestic environment this product may cause radio interference in which case the user may be required to take adequate measures.

## 2. FEATURES

- Exchanges, Multi interface units, and IP stations can be distributed over a data communications network.
- Can be connected to an existing local area network (LAN) or wide-area network (WAN). The system can also be easily connected to fiber-optic networks without restrictions on operating distance.
- The dedicated software program enables centralized control with a personal computer.
- System maintenance (verifying operation log and Line supervision) can also be performed with a personal computer and Internet browser.
- Can be connected to the PBX exchange via the analog E&M interface.
- The Multi interface unit can interlock with an electronic lock system or CCTV surveillance system by way of contact input/output control function.
- Using IP stations permits a system having no exchange to be created. However, the system configured only with IP door stations cannot be realized.

## 3. HANDLING PRECAUTIONS

The Internet is not guaranteed quality. So, when this system is connected to the Internet, packet loss may result if the network is congested, possibly causing voice communications to be interrupted or noise to be generated.

## 4. SPECIFICATIONS

Number of Units Connectable to LAN: Maximum 80 (a total of Exchanges, Multi interface units and IP stations)

Line Capacity: Maximum 1,280 (80 Exchanges x 16 stations per Exchange)

Speech Link Capacity: Maximum 320 (80 Exchanges)

Single Exchange

AN-8000EX: 4 links

Unit to unit

AN-8000EX: 8 links

AN-8000MI: 2 links

Speech: Maximum 2 links

Audio input: Maximum 2 links

Audio output: Maximum 2 links

**Note**

The above links can be simultaneously used.

(Refer to the table on p. 1-6.)

Paging

Paging Zones: Maximum 160

Paging Outputs: Maximum 160 (When 80 Exchanges or Multi interface units are connected)

AN-8000EX: 2 outputs

AN-8000MI: 2 outputs

Simultaneous access capacity for paging links:

AN-8000EX: Multicast paging: Maximum 4 links

Unicast paging: 1 link

AN-8000MI: Multicast paging: Maximum 2 links

Unicast paging: 1 link

AN-8500MS: Multicast paging: 1 link

Unicast paging: 1 link

Paging Destinations Via Network: Maximum 79 (Multicast paging), Maximum 16 (Unicast paging)

BGM: Maximum 8 channels (Number of channels selectable at the station.)

PBX Interface: Maximum 160 (When 80 Multi interface units are connected)

External Contact Output: Maximum 1,280 (When 80 Multi interface units are connected)

External Contact Input: Maximum 1,280 (When 80 Multi interface units are connected)

System Settings: Personal computer setting using a dedicated software program (over LAN)

(Network Related)

Voice Delay Time: 80 or 320 ms, selectable

Connection Delay Time: Maximum 1 second (When Multicast paging is made to 79 zones)

Usage Bandwidth: Maximum 2.08 Mbps (one way)/When Unicast paging is made to 16 zones

Maximum 130 kbps (two-way)/one call

## 5. SYSTEM CONFIGURATION

### 5.1. System Configuration Example

This system consists of the following equipment.

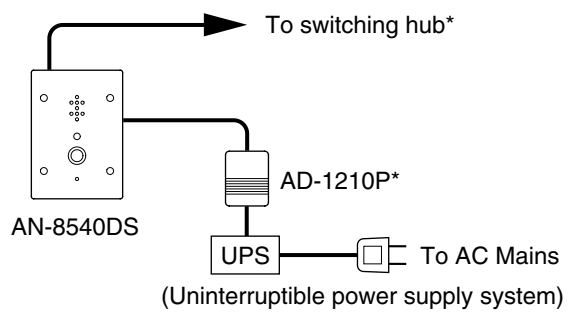
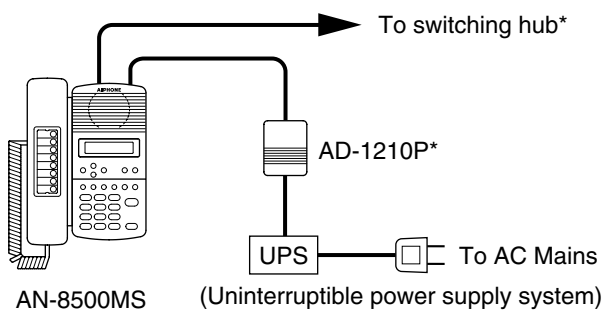
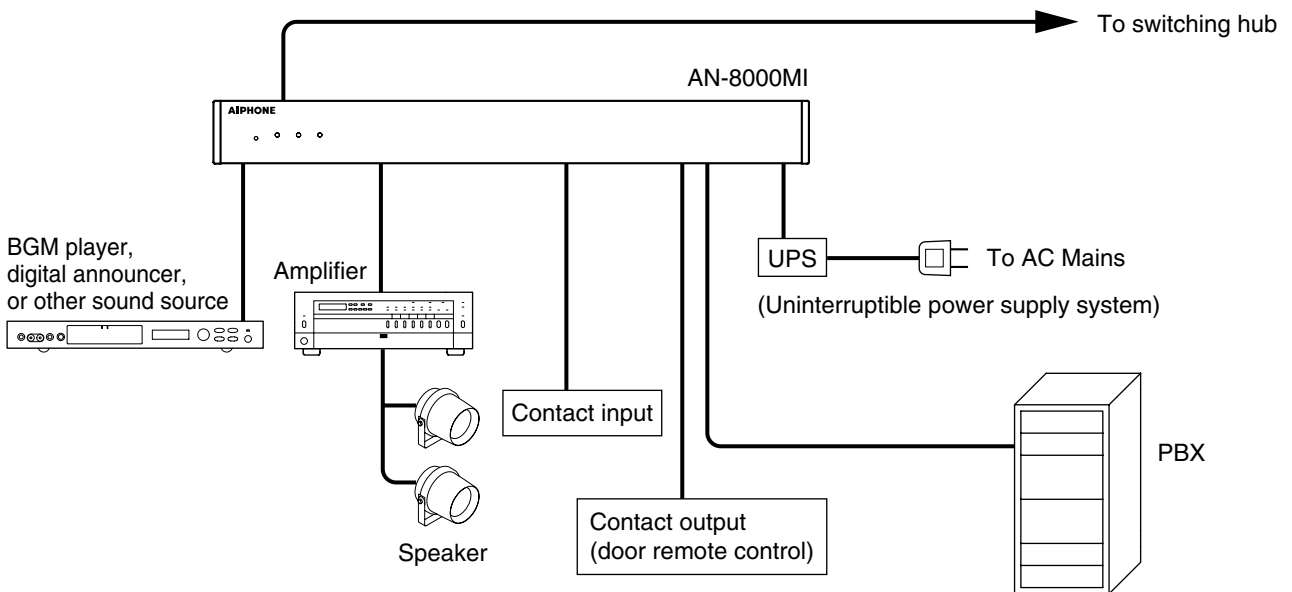
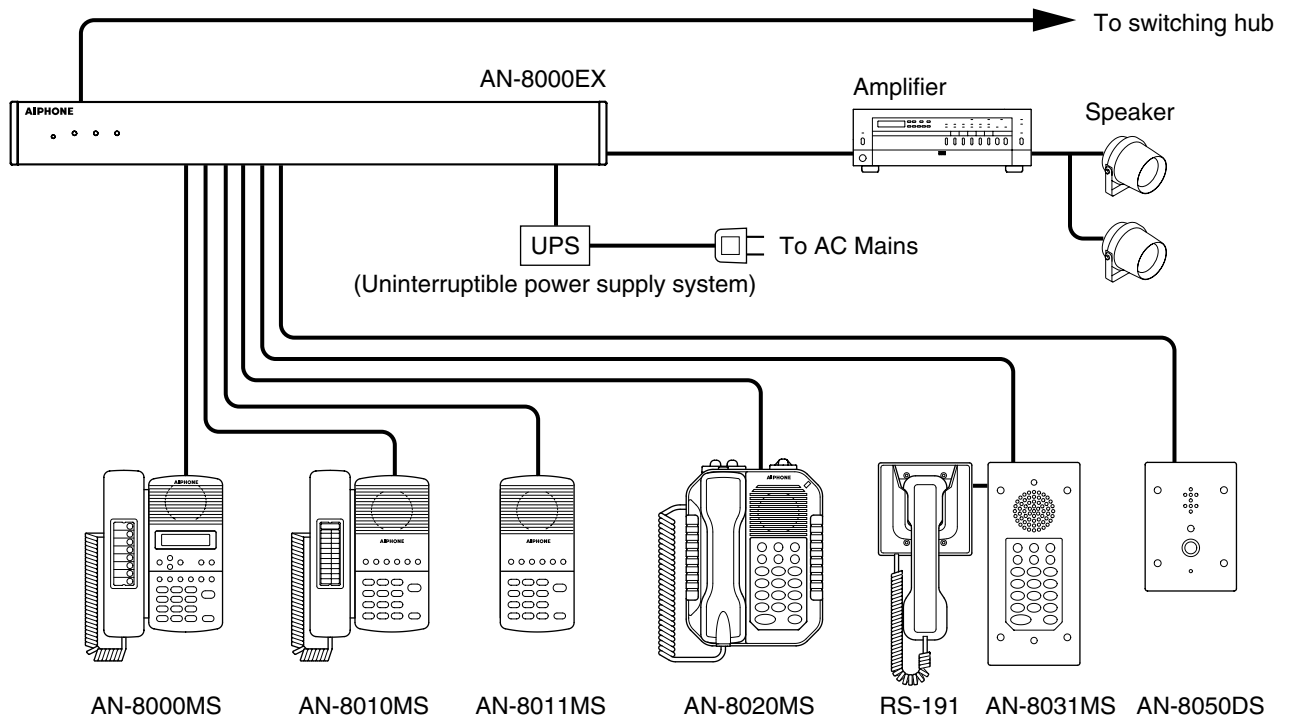

\* Connecting the station to a PoE (Power over Ethernet) switching hub eliminates the need for an AC adapter. In such a case, connect the switching hub to a UPS.

**5.1.1. Exchange**

AN-8000EX: IP Intercom Exchange

**5.1.2. Peripheral Components**

AN-8000MI: Multi Interface Unit

**5.1.3. IP Stations**

AN-8500MS: IP Multifunctional Master Station

AN-8540DS: IP Door Station

**5.1.4. Stations**

AN-8000MS: Multifunctional Master Station

AN-8010MS: Standard Master Station

AN-8011MS: Standard Hands-Free Master Station

AN-8020MS: Industrial-Use Master Station

AN-8031MS: Flush-Mount Master Station

RS-191: Option Handset

AN-8050DS: Door Station

**5.1.5. Others**

YC-280: Wall mounting bracket for the AN-8000MS/8010MS/8020MS/8500MS

YC-290: Wall mounting bracket for the AN-8011MS

YC-241: Back box for the AN-8031MS

YC-251: Wall-mount box for the AN-8031MS

YC-150: Back box for the AN-8050DS/8540DS

YS-13A: Wall-mount box for the AN-8050DS/8540DS

AD-1210P: AC adapter for the AN-8500MS/8540DS

E-7000TB: 40-Station Terminal Board

CR-273: Equipment Rack

CR-413: Equipment Rack

**5.2. Component Description****5.2.1. Exchange****[AN-8000EX IP Intercom Exchange]**

The Exchange permits connection of up to sixteen AN-8000 Series stations and features two outputs for public address paging. The speech links consist of 4 internal links and 8 external links. The exchange is equipped with a networking interface, allowing connection with IP stations, multi interface units, and other IP intercom exchanges. The Exchange can be mounted in an EIA standard rack (1U), to a wall or installed on a desk.

## 5.2.2. Peripheral components

### [AN-8000MI Multi Interface Unit]

Having 2 channels each for audio input and output, and 16 contacts each for control input and output, the AN-8000MI performs the following interface functions\*.

- PBX interface for connection with the PBX via the analog E&M interface.
- PA paging interface for connection with PA equipment
- External input broadcast interface for connection with a music player (chime unit) or paging microphone irrespective of with or without remote control function.
- Interface to control an indicator or external equipment such as a CCTV's switcher using relay contacts.

The AN-8000MI also features Network interface for connection with IP stations, IP intercom exchanges, and other multi interface units.

\* The interface functions can be combined in the following 4 patterns.

Interface function	Combination pattern			
	1	2	3	4
PBX 1	✓	✓	—	—
PBX 2	✓	—	✓	—
Audio output 1	—	—	✓	✓
Audio output 2	—	✓	—	✓
Audio input 1	—	—	✓	✓
Audio input 2	—	✓	—	✓
Contact IN/OUT	✓	✓	✓	✓

## 5.2.3. IP stations

Type of Stations	Specification												
	Speech Method			Installation Method				LCD Display	Auto-dialing	External speaker	External control	PC cascade-connection	Power
	Handset	Hands-free	Headset	Desk top	Wall hanging	Flush-mounting	Wall surface mounting						
AN-8500MS: IP Multifunctional Master Station	✓	✓	✓	✓ <sup>*1</sup>	✓ <sup>*2</sup>	—	—	✓	✓	✓	—	✓	✓ <sup>*3</sup>
AN-8540DS: IP Door Station	—	✓	—	—	—	✓ <sup>*4</sup>	✓ <sup>*5</sup>	—	—	—	✓	—	✓ <sup>*3</sup>

\*1 The front operation panel can be inclined 16° from the desk surface by attaching the YC-280 Wall Mounting Bracket to its bottom surface.

\*2 A dedicated YC-280 Wall Mounting Bracket is required.

\*3 A PoE (Power over Ethernet) switching hub compliant with IEEE802.3af or optional AD -1210 AC Adapter is required.

\*4 A dedicated YC-150 Back Box is required.

\*5 A dedicated YS-13A Wall-Mount Box is required.

### 5.2.4. Stations

Type of Stations	Specification											
	Speech Method			Installation Method				LCD Display	Auto-dialing	External speaker	External control	External dial input
	Handset	Hands-free	Headset	Desk top	Wall hanging	Flush-mounting	Wall surface mounting					
AN-8000MS: Multifunctional Master Station	✓	✓	✓	✓ <sup>*1</sup>	✓ <sup>*3</sup>	—	—	✓	✓	✓	—	—
AN-8010MS: Standard Master Station	✓	✓	—	✓ <sup>*1</sup>	✓ <sup>*3</sup>	—	—	—	—	—	—	—
AN-8011MS: Standard Hands-Free Master Station	—	✓	—	✓ <sup>*2</sup>	✓ <sup>*4</sup>	—	—	—	—	—	—	—
AN-8020MS: Industrial-Use Master Station	✓	✓	—	✓ <sup>*1</sup>	✓ <sup>*3</sup>	—	—	—	—	✓	✓	—
AN-8031MS: Flush-Mount Master Station	— <sup>*5</sup>	✓	—	—	—	✓ <sup>*6</sup>	✓ <sup>*7</sup>	—	—	—	—	✓
AN-8050DS: Door Station	—	✓	—	—	—	✓ <sup>*8</sup>	✓ <sup>*9</sup>	—	—	—	✓	—

\*1 The front operation panel can be inclined 16° from the desk surface by attaching the YC-280 Wall Mounting Bracket to its bottom surface.

\*2 The front operation panel can be inclined 16° from the desk surface by attaching the YC-290 Wall Mounting Bracket to its bottom surface.

\*3 A dedicated YC-280 Wall Mounting Bracket is required.

\*4 A dedicated YC-290 Wall Mounting Bracket is required.

\*5 Permits handset conversation when used in conversation with the RS-191 Option Handset

\*6 A dedicated YC-241 Back Box is required.

\*7 A dedicated YC-251 Wall-Mount Box is required.

\*8 A dedicated YC-150 Back Box is required.

\*9 A dedicated YS-13A Wall-Mount Box is required.

### 5.2.5. Others

#### [40-Station Terminal Board E-7000TB]

The E-7000TB is a clip type terminal board for connecting station lines to each exchange. Up to 40 lines (twisted pair cables) can be connected. The optional YC-105 clipping tool is required for wiring. The E-7000TB is rack-mountable (3U size).

#### [Equipment Racks CR-273 and CR-413]

The Exchange, 40-station terminal board, and other equipment components are mounted in these racks.



### 5.3. Rack Mounting Examples for Exchanges

#### 5.3.1. A 128-line exchange system

One CR-273 Equipment Rack is used.

#### 5.3.2. A 192-line exchange system

One CR-413 Equipment Rack is used.

#### 5.3.3. A 256-line exchange system

Two CR-273 Equipment Racks are used.

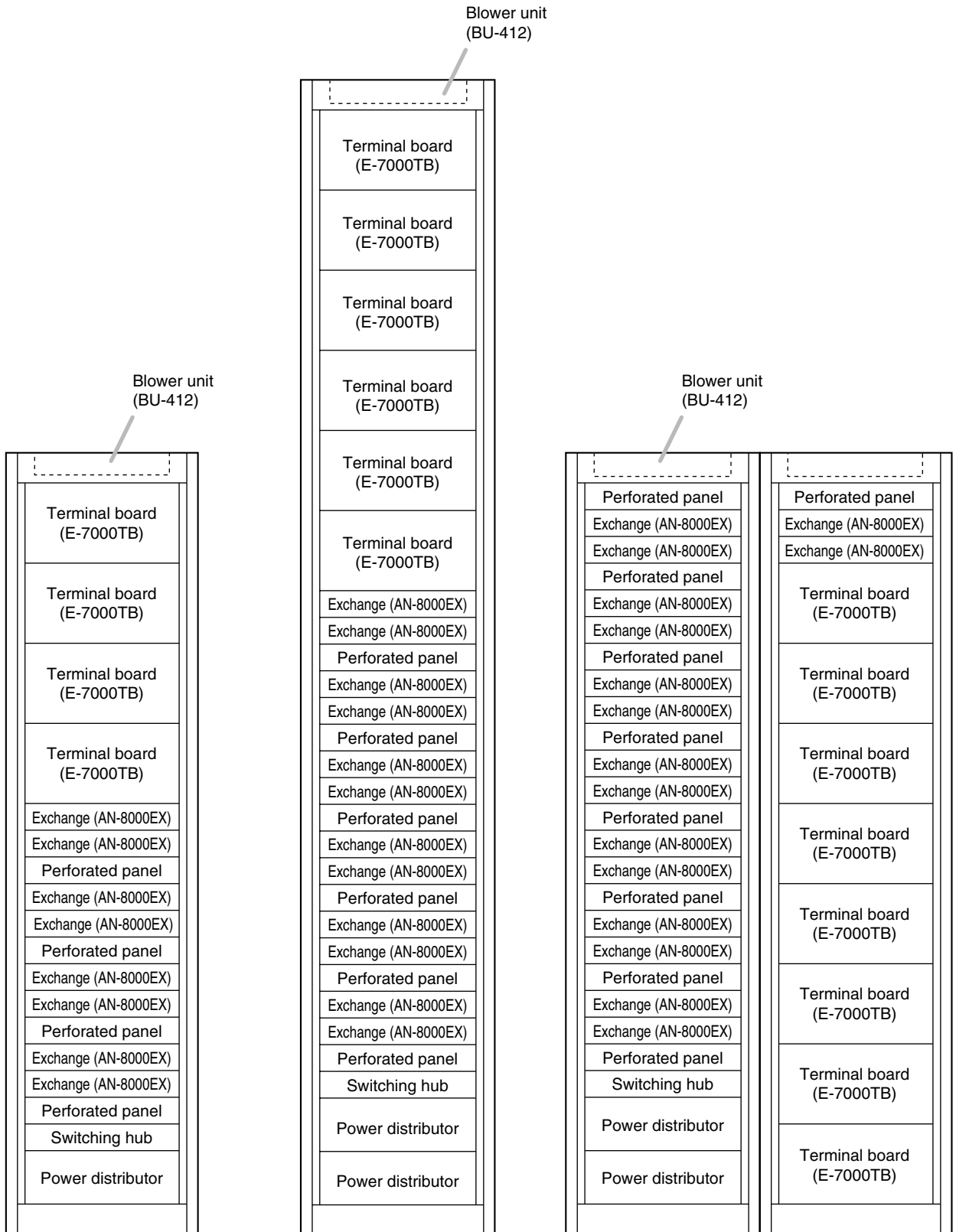

128-line exchange (CR-273)

192-line exchange (CR-413)

256-line exchange (CR-273)

### 5.3.4. A 1280-line exchange system

Seven CR-413 Equipment Racks are used.

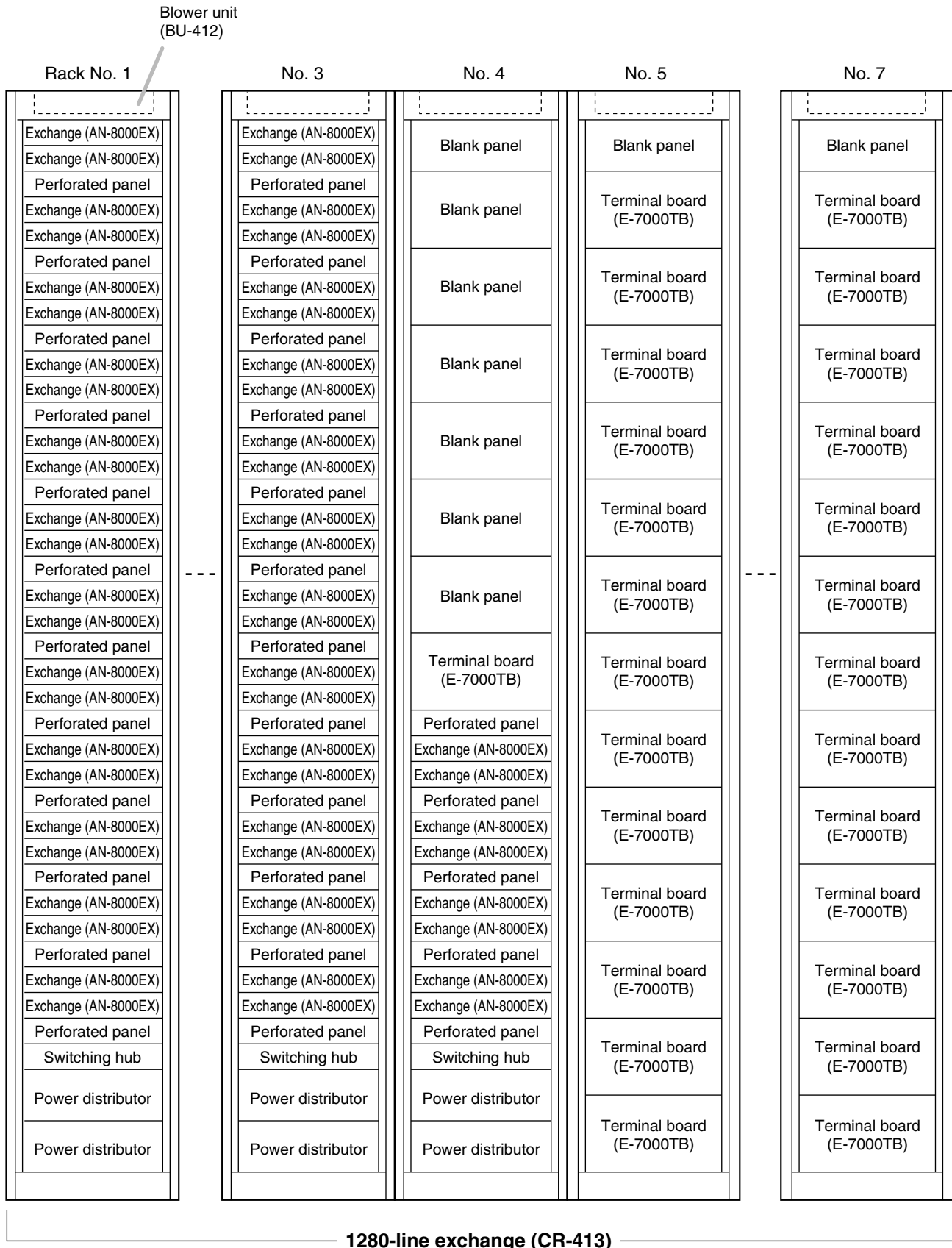

## 6. NOMENCLATURE AND FUNCTIONS

### 6.1. AN-8000EX IP Intercom Exchange

[Front]

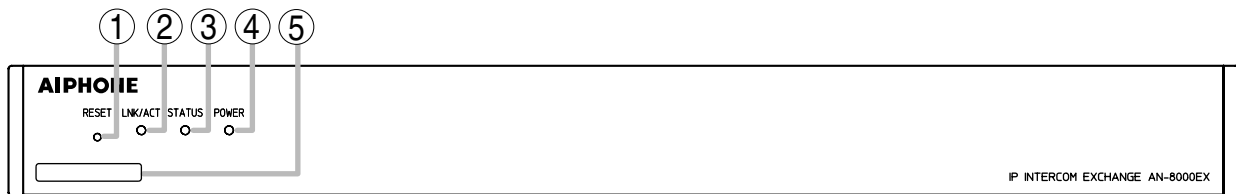

#### 1. Reset key [RESET]

Pressing this key reactivates the exchange.

#### 2. LNK/ACT indicator [LNK/ACT] (Green)

Lights when connected to a network, and flashes while transmitting or receiving data.

#### 3. Status indicator [STATUS] (Red)

Continuously lights while data is written to an internal storage medium (FlashMemory), and flashes to indicate such exchange malfunctions as cooling fan failure. (Refer to p. 8-8.)

#### 4. Power indicator [POWER] (Green)

Lights when power is supplied to the exchange.

#### 5. MAC address

This is the address\* used by the exchange. Since the relationship of each exchange location to its MAC address is established when setting the network attributes, keep track of this relationship for later use.

\* The inherent address assigned to each network component, expressed in 12-digit hexadecimal notation.

[Rear]

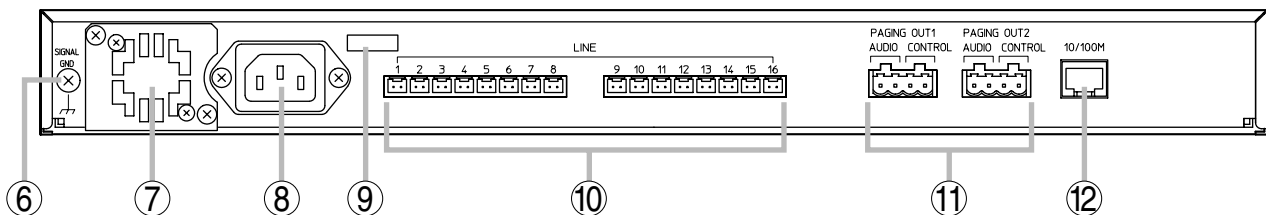

#### 6. Functional earth terminal [SIGNAL GND]

Ground this terminal.

**Note:** This terminal is not for protective earth.

#### 7. Cooling fan

##### ⚠ CAUTION

Do not block the fan exhaust vent. Doing so may cause heat to build up inside the unit and result in fire.

#### 8. AC inlet

Connects the supplied power cord.

##### Note

If there is a danger of lightning strikes, insert an appropriate surge arrester into the power line.

#### 9. Cord clamp

Pass the power cord through this clamp to ensure that the plug cannot be pulled out when the unit is mounted to a wall. (Refer to p. 3-4)

#### 10. Line connection terminals [LINE]

Connect the station to each terminal using a mini-clamp connector. (Refer to p. 3-32)

#### 11. Paging output terminals [PAGING OUT 1/2, AUDIO/CONTROL]

Includes audio outputs (0 dB\*, 600 Ω, balanced) and contact outputs (no-voltage make, 24 V DC, 0.5 A MAX).

Connect using a removable terminal plug. (Refer to p. 3-32)

#### 12. Network connection terminal [10/100M]

Connects a 10BASE-T- or 100BASE-TX-compatible network. (Ethernet RJ-45 jack)

\* 0 dB = 1 V

## 6.2. AN-8000MI Multi Interface Unit

### [Front]

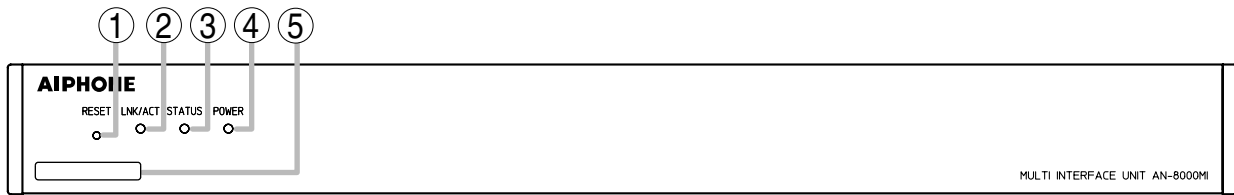

#### 1. Reset key [RESET]

Pressing this key reactivates the exchange.

#### 2. LNK/ACT indicator [LNK/ACT] (Green)

Lights when connected to a network, and flashes while transmitting or receiving data.

#### 3. Status indicator [STATUS] (Red)

Continuously lights while data is written to an internal storage medium (FlashMemory). Flashes if there is a failure. (Refer to [p. 8-8](#).)

#### 4. Power indicator [POWER] (Green)

Lights when power is supplied to the unit.

#### 5. MAC address

This is the address\*<sup>1</sup> used by the unit. Since the relationship of each exchange location to its MAC address is established when setting the network attributes, keep track of this relationship for later use.

\*<sup>1</sup> The inherent address assigned to each network component, expressed in 12-digit hexadecimal notation.

### [Rear]

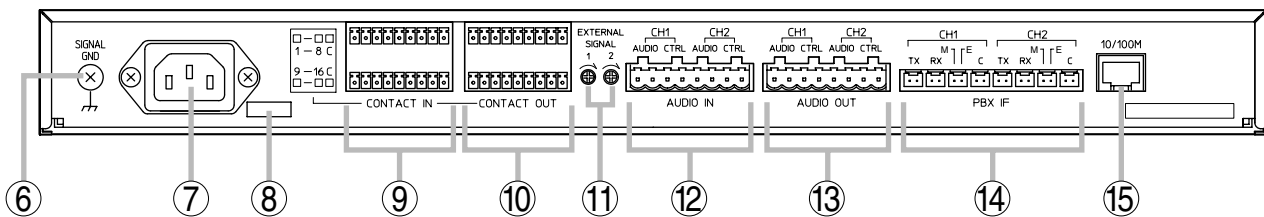

#### 6. Functional earth terminal [SIGNAL GND]

Be sure to ground this terminal unless the unit connects to a PBX.

**Note:** This terminal is not for protective earth.

#### 7. AC inlet

Connects the supplied power cord.

##### **Note**

If there is a danger of lightning strikes, insert an appropriate surge arrester into the power line.

#### 8. Cord clamp

Pass the power cord through this clamp to ensure that the plug does not pull out when the unit is mounted to a wall. (Refer to [p. 3-7](#).)

#### 9. Contact input terminals [CONTACT IN]

No-voltage make contact inputs.

Short-circuit current: 10 mA, Open-circuit voltage: 12 V

#### 10. Contact output terminals [CONTACT OUT]

Relay contact outputs.

Withstand voltage: 24 V DC, Control current: Maximum 0.5 A

#### 11. Input volume controls [EXTERNAL SIGNAL 1, 2]

Use these controls to adjust the audio input levels for channels 1 and 2 according to the input sources.

#### 12. Audio input terminal [AUDIO IN]

Includes audio inputs (maximum 0 dB\*<sup>2</sup>, over 10 k $\Omega$ , balanced) and contact inputs (no-voltage make contact, short-circuit current: 10 mA, open-circuit voltage: 12 V).

#### 13. Audio output terminal [AUDIO OUT]

Includes audio outputs (maximum 0 dB\*<sup>2</sup>, under 600  $\Omega$ , balanced) and control outputs (relay contact withstand voltage: 24 V DC, control current: maximum 0.5 A).

#### 14. PBX interface terminal [PBX IF]

Connects to the PBX exchange via the analog E&M interface.

#### 15. Network connection terminal [10/100M]

Connects to a 10BASE-T- or 100BASE-TX-compatible network. (Ethernet RJ-45 jack)

\*<sup>2</sup> 0 dB = 1 V

### 6.3. AN-8500MS IP Multifunctional Master Station

[Top]

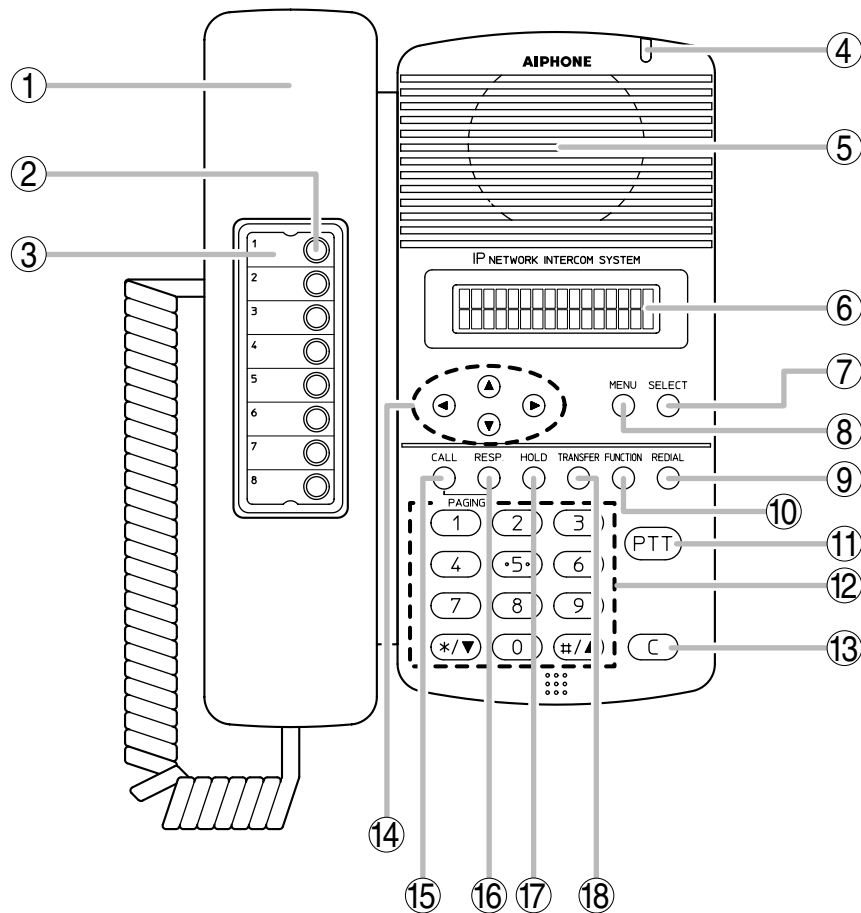

#### 1. Handset

Lift the handset for handset conversation. Lifting the handset disconnects both the hands-free microphone and the speaker.

#### 2. Auto-dial key

Used to call or register the party to be called. (Refer to [p. 2-9](#).)

#### 3. Auto-dial directory

Writes the auto-dial registration contents to this directory.

#### 4. Status indicator (Red)

Flashes when a call or paging announcement is received, continuously lights during conversation, and is off while in standby mode. The indicator also continuously lights while data is written to an internal storage memory (FlashMemory), and flashes if there is a failure. (Refer to [p. 8-8](#).)

#### 5. Speaker

Outputs call tones and used for hands-free conversations.

#### 6. Liquid crystal display

Displays the dialed number or the number of a call received in 2 lines of 16 digits. Pressing the Menu key (8) displays the menu screen.

#### 7. Selection key [SELECT]

Used for menu item selection or input value confirmation.

#### 8. Menu key [MENU]

Used for auto-dial registration (refer to [p. 2-9](#)) or system settings. (Refer to [Chapter 7](#).)

#### 9. Redial key [REDIAL]

Permits the last called number to be dialed. (Refer to [p. 2-6](#).)

#### 10. Function key [FUNCTION]

Use this key to perform function settings such as assigning call transfer recipients or programming one-touch dialing.

**11. Push-to-talk key [PTT]**

Pressing this key while calling a party by means of a continuous call tone permits a voice call to be made. (Refer to [p. 2-7.](#)) Also, pressing this key during a hands-free conversation establishes a one-way conversation from the party who pressed the key. (Refer to [p. 2-6.](#))

**12. Dial keys**

Use these keys to make a call or set a function.

**13. Clear key [C]**

Terminates the conversation.

**14. Arrow keys [▲][▼][◀][▶]**

Use these keys to perform auto-dial registration (refer to [p. 2-9](#)) or system settings (refer to [Chapter 7](#)).

**15. Paging key [CALL]**

Makes a paging. (Refer to [p. 2-23.](#))

**16. Paging response key [RESP.]**

Responds to a paging.  
(Refer to [p. 2-27.](#))

**17. Hold key [HOLD]**

Places the conversation on hold.  
(Refer to [p. 2-11.](#))

**18. Transfer key [TRANSFER]**

Used to transfer the current conversation to another station. (Refer to [p. 2-12.](#))

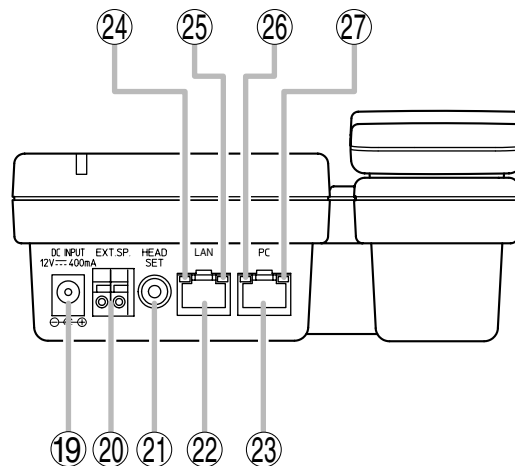
**[Rear]****19. AC adapter terminal [DC INPUT]**

Connect the AC adapter\* to this terminal.

\* Use the AD-1210P (optional) or its equivalent.

**20. External speaker terminal [EXT.SP.]**

An external speaker (8  $\Omega$ , 0.6 W) can be connected to this terminal. (Refer to [p. 3-29.](#))

Shift the Speaker selector switch (29) located on the bottom surface of the unit to the EXT.SP position when using the external speaker.

**21. Headset terminal [HEADSET]**

Connects to a headset. Connection of the headset disables the speaker.

**22. Network connection terminal [LAN]**

Can be connected to a network of 10BASE-T/100BASE-TX in auto-sensing.

Connecting the station to a PoE (Power over Ethernet) switching hub eliminates the need for an AC adapter.

(Ethernet RJ-45 jack)

**23. PC connection terminal [PC]**

A PC can be cascaded with the station.

(Not compatible with PoE function)  
(Ethernet RJ-45 jack)

**24. ACT indicator (Green)**

Lights while transmitting or receiving data.

**25. FD indicator (Yellow)**

Lights when the network is in full duplex communications.

**26. ACT indicator (Green)**

Lights while the connected PC is transmitting or receiving data.

**27. FD indicator (Yellow)**

Lights when a PC is connected.

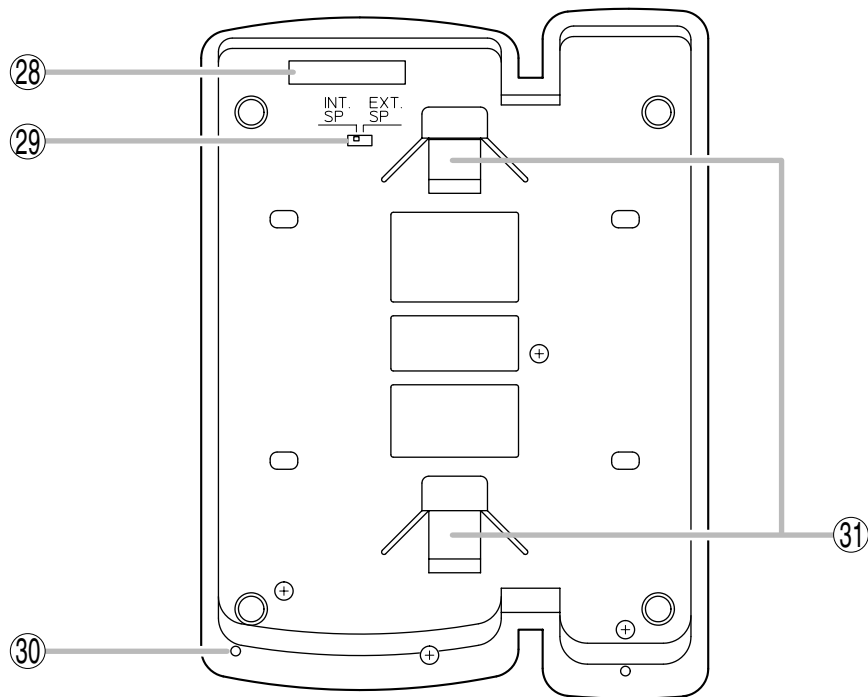
**[Bottom]****28. MAC address**

This is the address\* used by the IP station. Since the relationship of each IP station location to its MAC address is established when setting the network attributes, keep track of this relationship for later use.

\* The inherent address assigned to each network component, expressed in 12-digit hexadecimal notation.

**29. Speaker selector switch [INT.SP/EXT.SP]**

Used to select either an internal (INT.SP) or an external (EXT.SP) speaker.

**30. Microphone**

Used for hands-free conversation.

**Note**

Avoid placing obstacles close to the microphone that might block sound and prevent conversations.

**31. Wall bracket mounting slots**

Hang the mounting bracket hooks to these slots when using the YC-280 Wall Mounting Bracket. (Refer to [p. 3-9](#), [3-13](#).)

## 6.4. AN-8540DS IP Door Station

[Front]

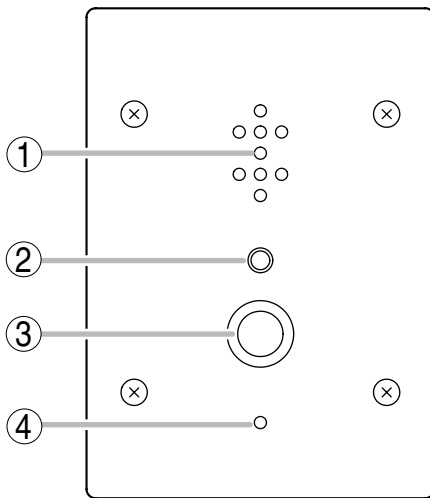

[Side]

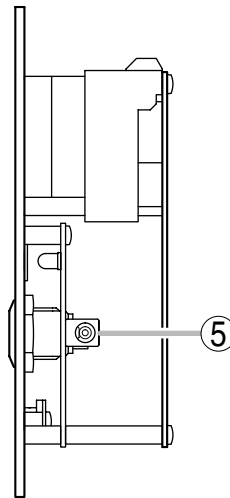

[Rear]

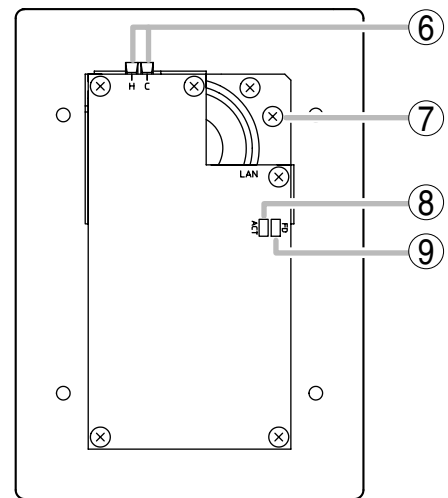

[Top]

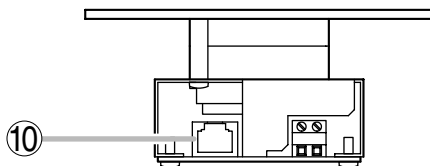

### 1. Speaker

Outputs call tones and used for hands-free conversations.

### 2. Status indicator (Red)

Flashes when a call or paging announcement is received, continuously lights during conversation, and is off while in standby mode. The indicator also continuously lights while data is written to an internal storage memory (FlashMemory), and flashes if there is a failure.

(Refer to [p. 8-8](#).)

### 3. Call button

Used to call the pre-programmed master station.

### 4. Microphone

Used for hands-free conversation.

### 5. AC adapter terminal

Connect the AC adapter\* to this terminal.

\* Use the AD-1210P (optional) or its equivalent.

### 6. Contact output terminals [H, C]

External equipment such as an electronic lock can be connected.

Can be shorted momentarily by the operation from the conversation party's master station.

(Output capacity: 30 V DC and 50 mA)

(Refer to [p. 3-30](#).)

### 7. Frame ground terminal (FG)

Ground from this terminal when the switch box is not grounded.

### 8. ACT indicator (Green)

Lights while transmitting or receiving data.

### 9. FD indicator (Yellow)

Lights when the network is in full duplex communications.

### 10. Network connection terminal [PC]

Can be connected to a network of 10BASE-T/100BASE-TX in auto-sensing.

Connecting the station to a PoE (Power over Ethernet) switching hub eliminates the need for an AC adapter.

(Ethernet RJ-45 jack)



## 6.5. AN-8000MS Multifunctional Master Station

[Top]

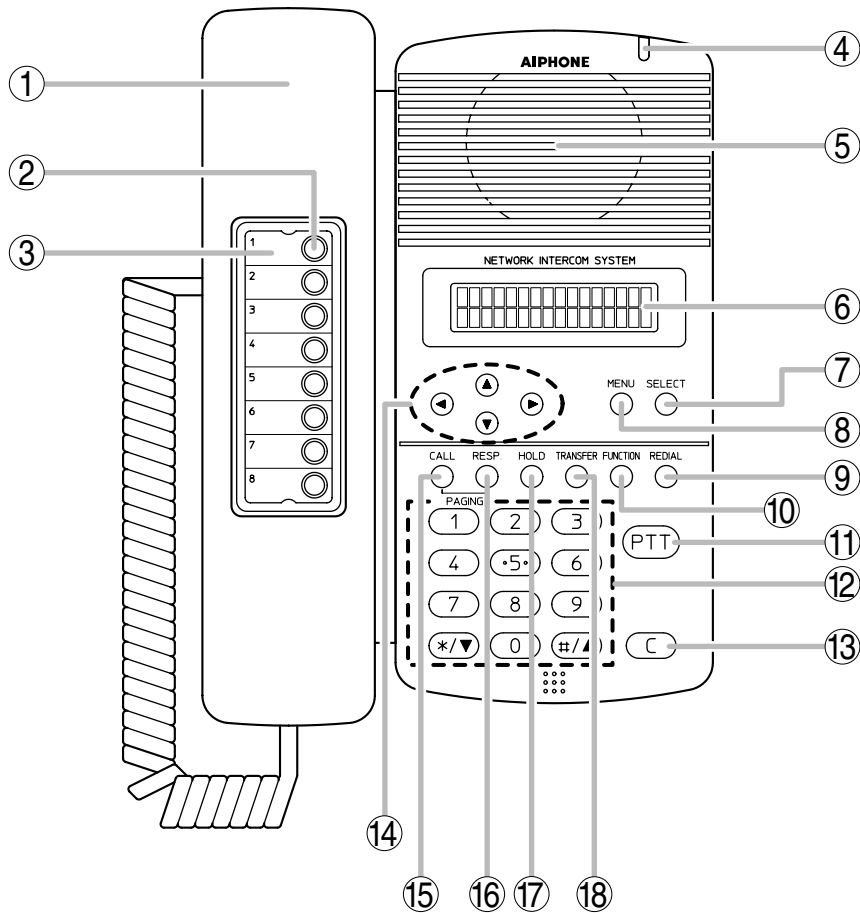
**1. Handset**

Lift the handset for handset conversation. Lifting the handset disconnects both the hands-free microphone and the speaker.

**2. Auto-dial key**

Used to call or register the party to be called. (Refer to [p. 2-9](#).)

**3. Auto-dial directory**

Writes the auto-dial registration contents to this directory.

**4. Status indicator (Red)**

Flashes when a call is received, continuously lights during a conversation, and is off while in standby mode. The indicator also continuously lights while receiving a paging announcement.

**5. Speaker**

Outputs call tones and used for hands-free conversations.

**6. Liquid crystal display**

Displays the dialed number or the number of a call received in 2 lines of 16 digits. Pressing the Menu key (8) displays the menu screen.

**7. Selection key [SELECT]**

Used for menu item selection or input value confirmation.

**8. Menu key [MENU]**

Used for auto-dial registration (refer to [p. 2-9](#)) or system settings. (Refer to [Chapter 7](#).)

**9. Redial key [REDIAL]**

Permits the last called number to be dialed. (Refer to [p. 2-6.](#))

**10. Function key [FUNCTION]**

Use this key to perform function settings such as assigning call transfer recipients or programming one-touch dialing.

**11. Push-to-talk key [PTT]**

Pressing this key while calling a party by means of a continuous call tone permits a voice call to be made. (Refer to [p. 2-7.](#)) Also, pressing this key during a hands-free conversation establishes a one-way conversation from the party who pressed the key. (Refer to [p. 2-6.](#))

**12. Dial keys**

Use these keys to make a call or set a function.

**13. Clear key [C]**

Terminates the conversation.

**14. Arrow keys [▲][▼][◀][▶]**

Use these keys to perform auto-dial registration (refer to [p. 2-9](#)) or system settings (refer to [Chapter 7](#)).

**15. Paging key [CALL]**

Makes a paging. (Refer to [p. 2-23.](#))

**16. Paging response key [RESP.]**

Responds to a paging. (Refer to [p. 2-27.](#))

**17. Hold key [HOLD]**

Places the conversation on hold. (Refer to [p. 2-11.](#))

**18. Transfer key [TRANSFER]**

Used to transfer the current conversation to another station. (Refer to [p. 2-12.](#))

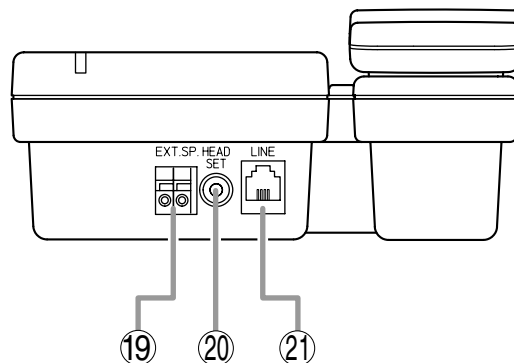
**[Rear]****19. External speaker terminal [EXT.SP.]**

An external speaker (8 Ω, 0.6 W) can be connected to this terminal. (Refer to [p. 3-23.](#))

Shift the Speaker selector switch (22) located on the bottom surface of the unit to the EXT.SP position when using the external speaker.

**20. Headset terminal [HEADSET]**

Connects to a headset. Connection of the headset disables the speaker.

**21. Line connection terminal [LINE]**

Connects to the exchange. (RJ-11 modular jack)

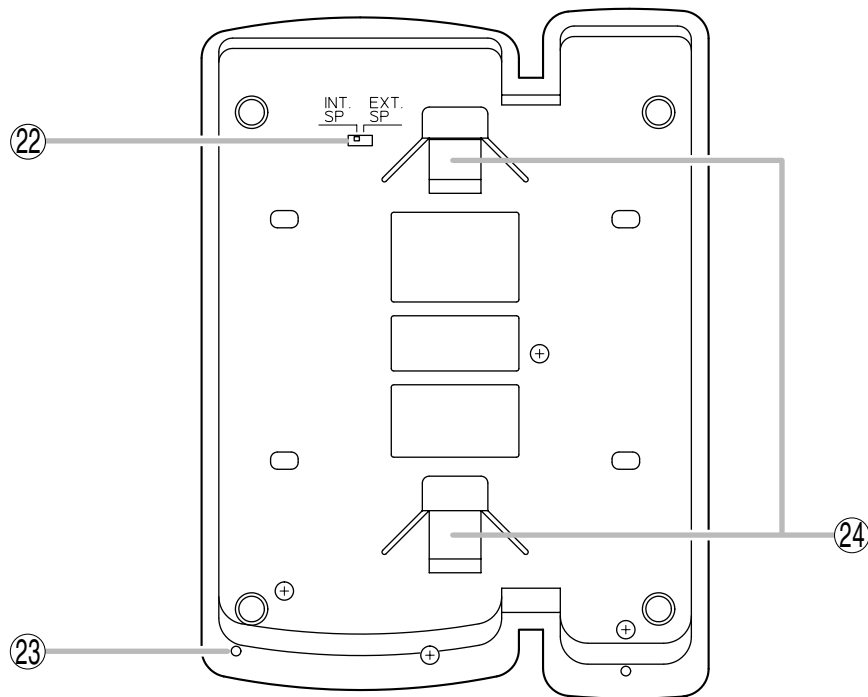
**[Bottom]****22. Speaker selector switch [INT.SP/EXT.SP]**

Used to select either an internal (INT.SP) or an external (EXT.SP) speaker.

**23. Microphone**

Used for hands-free conversation.

**Note**

Avoid placing obstacles close to the microphone that might block sound and prevent conversations.

**24. Wall bracket mounting slots**

Hang the mounting bracket hooks to these slots when using the YC-280 Wall Mounting Bracket. (Refer to [p. 3-9](#), [3-13](#).)

## 6.6. AN-8010MS Standard Master Station

[Top]

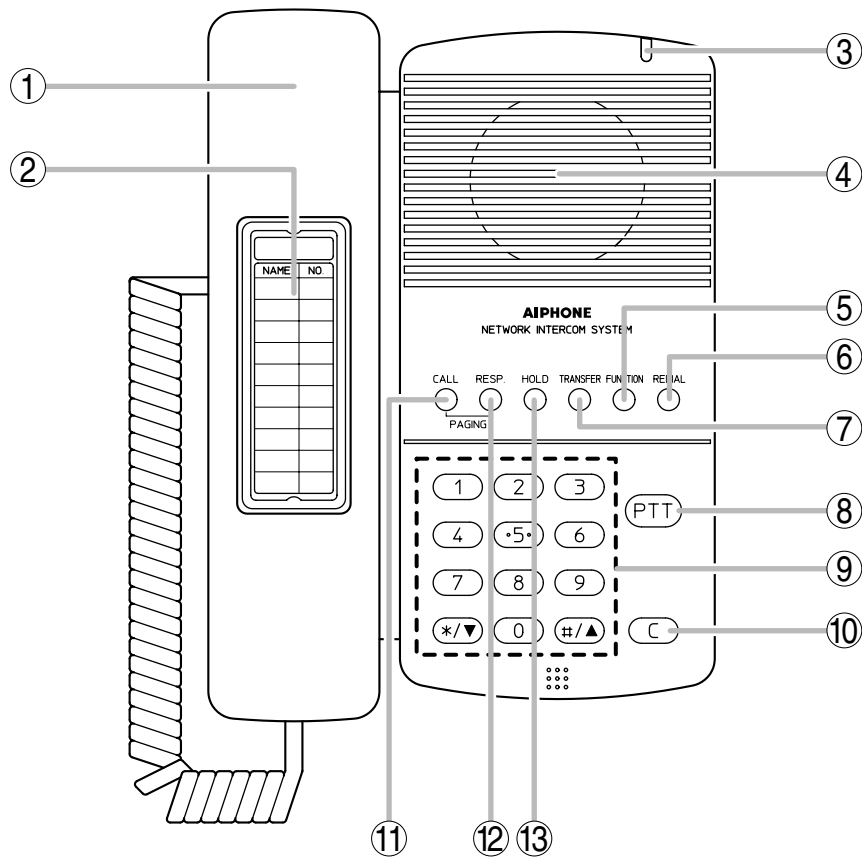

### 1. Handset

Lift the handset for handset conversation. Lifting the handset disconnects both the hands-free microphone and the speaker.

### 2. Dial directory

Writes the dial registration of the party to be called to this directory.

### 3. Status indicator (Red)

Flashes when a call is received, continuously lights during a conversation, and is off while in standby mode. The indicator also continuously lights while receiving a paging announcement.

### 4. Speaker

Outputs call tones and used for hands-free conversations.

### 5. Function key [FUNCTION]

Use this key to perform function settings such as assigning call transfer recipients or programming one-touch dialing.

### 6. Redial key [REDIAL]

Permits the last called number to be dialed. (Refer to p. 2-6.)

### 7. Transfer key [TRANSFER]

Used to transfer the current conversation to another station. (Refer to p. 2-12.)

### 8. Push-to-talk key [PTT]

Pressing this key while calling a party by means of a continuous call tone permits a voice call to be made. (Refer to p. 2-7.) Also, pressing this key during a hands-free conversation establishes a one-way conversation from the party who pressed the key. (Refer to p. 2-6.)

### 9. Dial keys

Use these keys to make a call or set a function.

### 10. Clear key [C]

Terminates the conversation.

### 11. Paging key [CALL]

Makes a paging. (Refer to p. 2-23.)

### 12. Paging response key [RESP.]

Responds to a paging. (Refer to p. 2-27.)

### 13. Hold key [HOLD]

Places the conversation on hold. (Refer to p. 2-11.)

**[Rear]**

- 14. Line connection terminal [LINE]**  
Connects to the exchange. (RJ-11 modular jack)

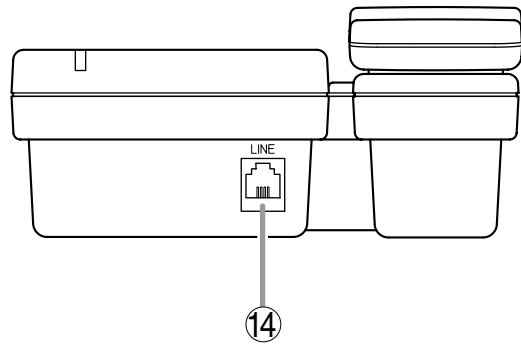

**[Bottom]**

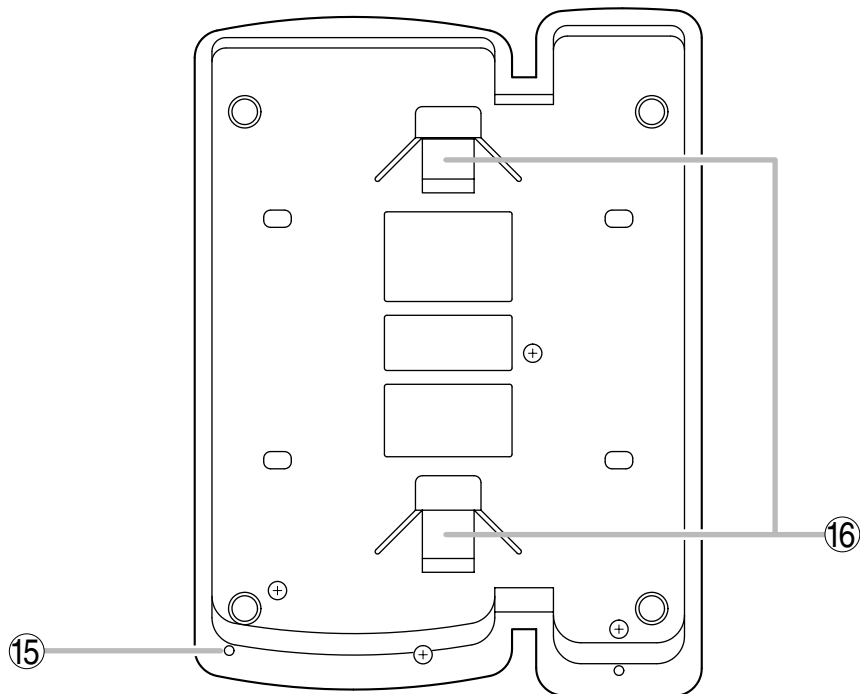

- 15. Microphone**  
Used for hands-free conversation.  
**Note**  
Avoid placing obstacles close to the microphone that might block sound and prevent conversations.

- 16. Wall bracket mounting slots**  
Hang the hooks of the mounting bracket to these slots when using the YC-280 Wall Mounting Bracket. (Refer to [p. 3-9, 3-13.](#))

## 6.7. AN-8011MS Standard Hands-free Master Station

[Top]

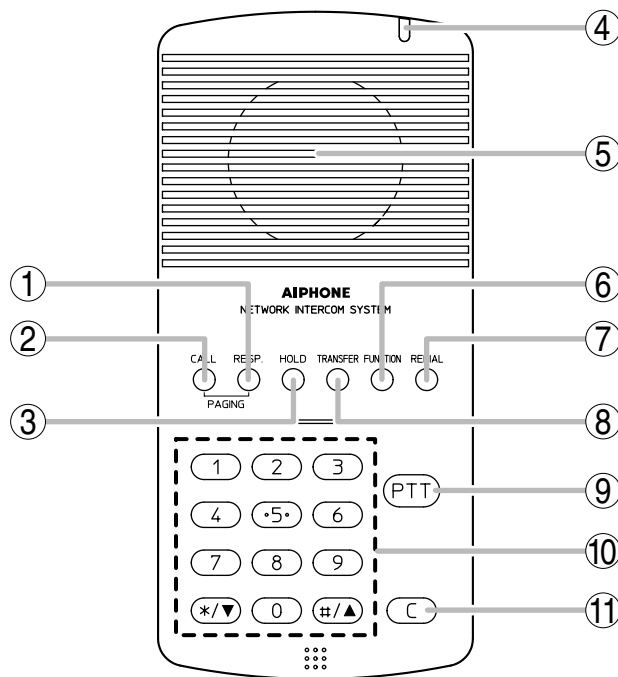

### 1. Paging response key [RESP.]

Responds to a paging. (Refer to [p. 2-27.](#))

### 2. Paging key [CALL]

Makes a paging. (Refer to [p. 2-23.](#))

### 3. Hold key [HOLD]

Places the conversation on hold.

(Refer to [p. 2-11.](#))

### 4. Status indicator (Red)

Flashes when a call is received, continuously lights during a conversation, and is off while in standby mode. The indicator also continuously lights while receiving a paging announcement.

### 5. Speaker

Outputs call tones and used for hands-free conversations.

### 6. Function key [FUNCTION]

Use this key to perform function settings such as assigning call transfer recipients or programming one-touch dialing.

### 7. Redial key [REDIAL]

Permits the last called number to be dialed. (Refer to [p. 2-6.](#))

### 8. Transfer key [TRANSFER]

Used to transfer the current conversation to another station. (Refer to [p. 2-12.](#))

### 9. Push-to-talk key [PTT]

Pressing this key while calling a party by means of a continuous call tone permits a voice call to be made. (Refer to [p. 2-7.](#)) Also, pressing this key during a hands-free conversation establishes a one-way conversation from the party who pressed the key. (Refer to [p. 2-6.](#))

### 10. Dial keys

Use these keys to make a call or set a function.

### 11. Clear key [C]

Terminates the conversation.

[Rear]

- 12. Line connection terminal [LINE]**  
Connects to the exchange. (RJ-11 modular jack)

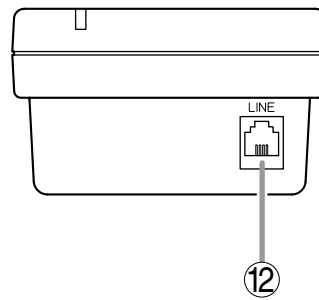

[Bottom]

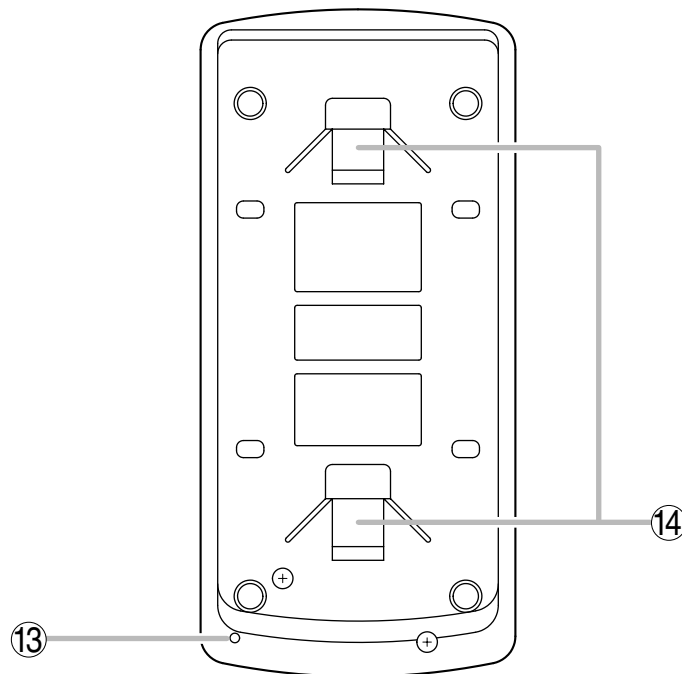

- 13. Microphone**  
Used for hands-free conversation.  
**Note**  
Avoid placing obstacles close to the microphone that might block sound and prevent conversations.

- 14. Wall bracket mounting slots**  
Hang the mounting bracket hooks to these slots when using the YC-290 Wall mounting bracket. (Refer to p. 3-11, 3-14.)

## 6.8. AN-8020MS Industrial-Use Master Station

[Top]

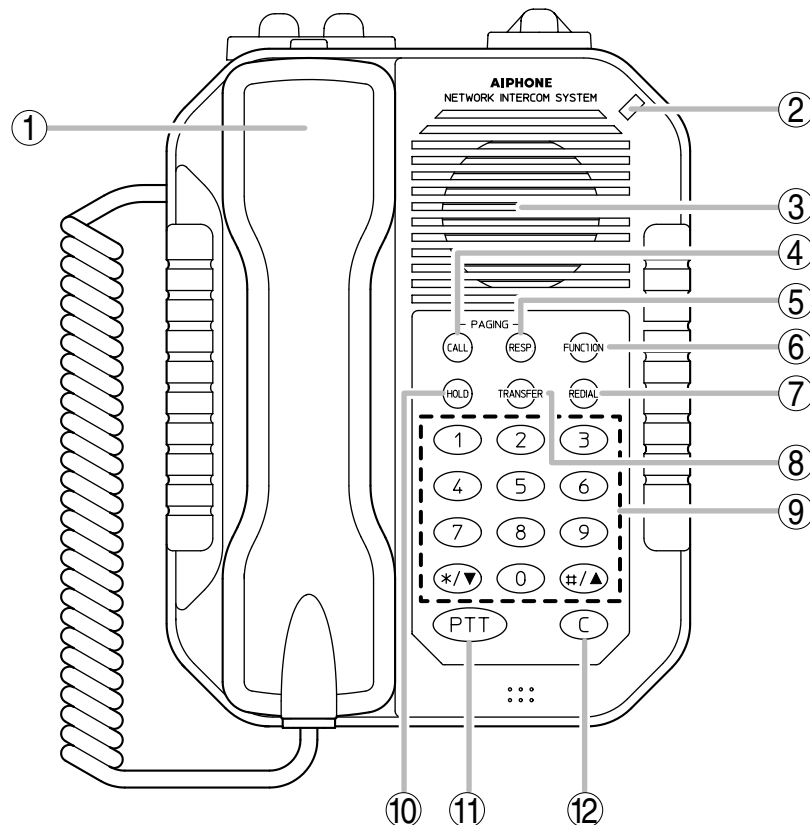

### 1. Handset

Lift the handset for handset conversation. Lifting the handset disconnects both the hands-free microphone and the speaker.

### 2. Status indicator (Red)

Flashes when a call is received, continuously lights during a conversation, and is off while in standby mode. The indicator also continuously lights while receiving a paging announcement.

### 3. Speaker

Outputs call tones and used for hands-free conversations.

### 4. Paging key [CALL]

Makes a paging. (Refer to [p. 2-23.](#))

### 5. Paging response key [RESP.]

Responds to a paging. (Refer to [p. 2-27.](#))

### 6. Function key [FUNCTION]

Use this key to perform function settings such as assigning call transfer recipients or programming one-touch dialing.

### 7. Redial key [REDIAL]

Permits the last called number to be dialed. (Refer to [p. 2-6.](#))

### 8. Transfer key [TRANSFER]

Used to transfer the current conversation to another station. (Refer to [p. 2-12.](#))

### 9. Dial keys

Use these keys to make a call or set a function.

### 10. Hold key [HOLD]

Places the conversation on hold. (Refer to [p. 2-11.](#))

### 11. Push-to-talk key [PTT]

Pressing this key while calling a party by means of a continuous call tone permits a voice call to be made. (Refer to [p. 2-7.](#)) Also, pressing this key during a hands-free conversation establishes a one-way conversation from the party who pressed the key. (Refer to [p. 2-6.](#))

### 12. Clear key [C]

Terminates the conversation.

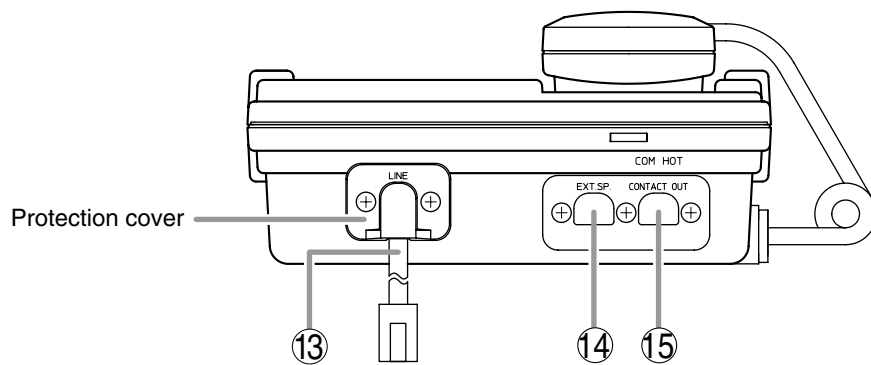

**[Rear]****13. Line connection cable [LINE]**

Connects to the exchange. (3 m-length cable with RJ-11 modular plug)

**Note:** Do not remove the protection cover.

**14. External speaker terminal [EXT.SP.]**

An external speaker (8  $\Omega$ , 0.6 W) can be connected to this terminal. When connecting, replace a protection cap with a supplied rubber bushing. (Refer to p. 3-23.)

Shift the Speaker selector switch (16) located on the bottom surface of the unit to the EXT.SP position when using the external speaker.

**15. Contact output terminal [CONTACT OUT]**

Permits connection of a device to indicate the calling station.

This terminal closes only while a call is being made or received. (Output capacity: 30 V DC and 50 mA.)

When connecting, replace a protection cap with a supplied rubber bushing. (Refer to p. 3-23.)

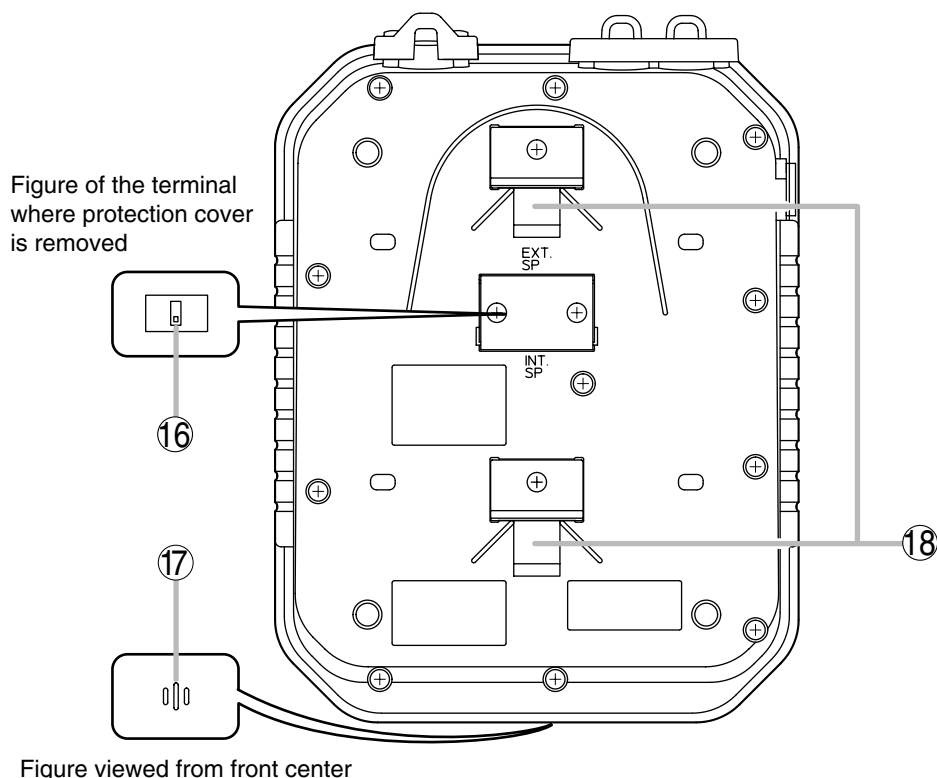
**[Bottom]****16. Speaker selector switch [INT.SP/EXT.SP]**

The internal switch is exposed if the protection cover is removed.

Used to select either an internal (INT.SP) or an external (EXT.SP) speaker. After shifting the selector switch, fit the protection cover back into place.

**Note**

Avoid placing obstacles close to the microphone that might block sound and prevent conversations.

**17. Microphone**

Used for hands-free conversation.

**18. Wall bracket mounting slots**

Hang the mounting bracket hooks to these slots when using the YC-280 Wall mounting bracket. (Refer to p. 3-9, 3-13.)

## 6.9. AN-8031MS Flush-Mount Master Station

[Front]

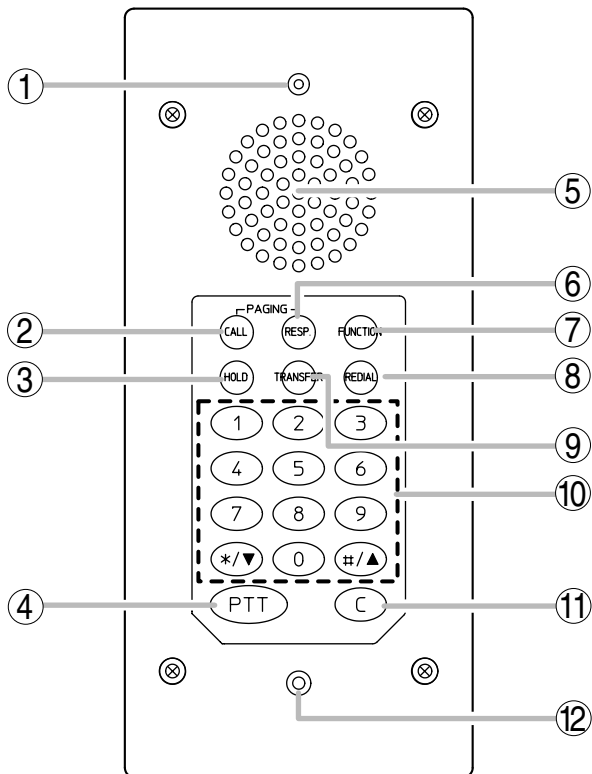

[Rear]

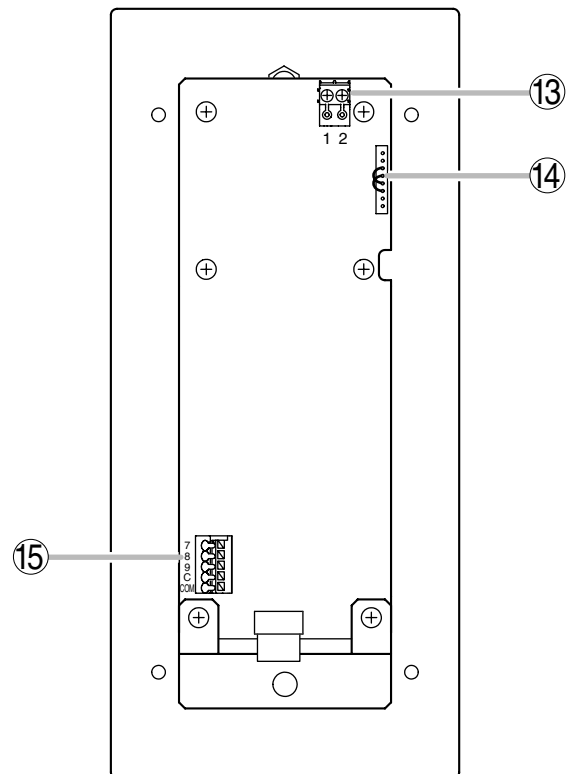
**1. Status indicator (Red)**

Flashes when a call is received, continuously lights during a conversation, and is off while in standby mode. The indicator also continuously lights while receiving a paging announcement.

**2. Paging key [CALL]**

Makes a paging. (Refer to [p. 2-23](#).)

**3. Hold key [HOLD]**

Places the conversation on hold. (Refer to [p. 2-11](#).)

**4. Push-to-talk key [PTT]**

Pressing this key while calling a party by means of a continuous call tone permits a voice call to be made. (Refer to [p. 2-7](#).) Also, pressing this key during a hands-free conversation establishes a one-way conversation from the party who pressed the key. (Refer to [p. 2-6](#).)

**5. Speaker**

Outputs call tones and used for hands-free conversations.

**6. Paging response key. [RESP.]**

Responds to a paging. (Refer to [p. 2-27](#).)

**7. Function key [FUNCTION]**

Use this key to perform function settings such as assigning call transfer recipients or programming one-touch dialing.

**8. Redial key [REDIAL]**

Permits the last called number to be dialed. (Refer to [p. 2-6](#).)

**9. Transfer key [TRANSFER]**

Used to transfer the current conversation to another station. (Refer to [p. 2-12](#).)

**10. Dial keys**

Use these keys to make a call or set a function.

**11. Clear key [C]**

Terminates the conversation.

**12. Microphone**

Used for hands-free conversation.

**13. Line connection terminals [1, 2]**

Connect to the exchange. (Pin header)

**Note**

The removable terminal plug (2P) is factory-attached. (Refer to [p. 3-22](#).)

**14. Handset connection terminals [CN302]**

A dedicated RS-191 Option Handset can be connected. (Refer to p. 3-24.)

**15. External dial input terminals [CN306]**

An external switch such as a footswitch can be connected. (Refer to p. 3-25.)

One-touch dial function needs be programmed when using the external switch. (Refer to p. 2-10.)

**6.10. AN-8050DS Door Station**

**[Front]**

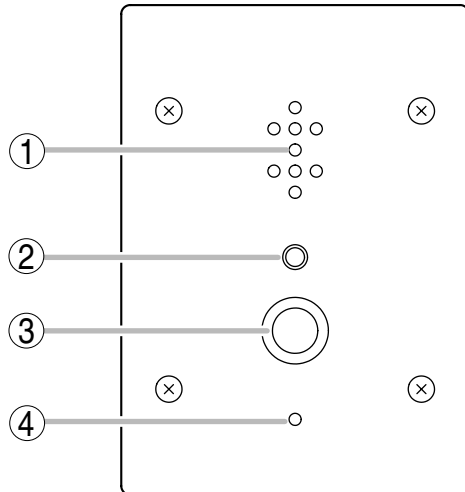

**[Rear]**

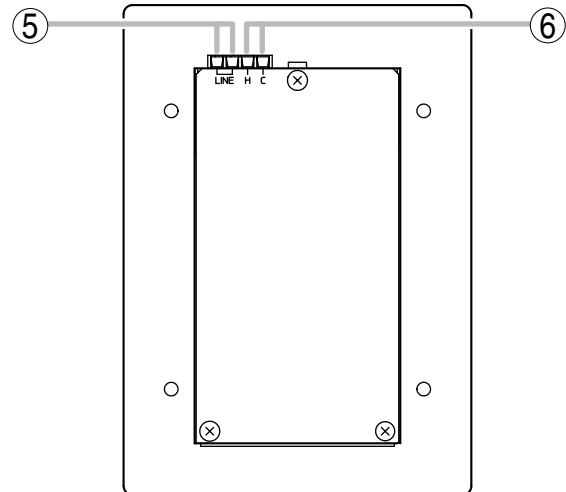

**1. Speaker**

Outputs call tones and used for hands-free conversations.

**2. Status indicator (Red)**

Flashes when a call is received, continuously lights during a conversation, and is off while in standby mode. The indicator also continuously lights while receiving a paging announcement.

**3. Call button**

Used to call the pre-programmed master station.

**4. Microphone**

Used for hands-free conversation.

**5. Line connection terminal [LINE]**

Connects to the exchange. (Terminal block) (Refer to p. 3-22.)

**6. Contact output terminals [H, C]**

External equipment such as an electronic lock can be connected.

Can be shorted momentarily by the operation from the conversation party's master station.

(Output capacity: 30 V DC and 50 mA) (Refer to p. 3-25.)

## 7. SYSTEM FUNCTION TABLE

### 7.1. Basic Functions

IP stations or the system consisting of Exchanges and stations makes the following functions available.

Function		Description	Reference page	
			Operation	Setting
Conversation	Hands-free conversation	Permits conversations to be made without lifting the handset when another party is called or when a call is received in automatic connection mode.	P. 2-5	—
	Handset conversation	Calls can be made or received by lifting the handset.	P. 2-5	—
	PTT conversation	Pressing the Push-to-talk key during a hands-free conversation enables one-way conversation from the party who pressed the Push-to-talk key. Conversation flow is reversed when the key is released. This function makes announcements and conversations possible to areas with a high ambient noise level.	P. 2-6	—
Call	Individual call	The desired party can be called by dialing its station number.	P. 2-6	—
	Redialing	Pressing the Redial key automatically redials the last number called. Only the AN-8000MS/8500MS permits selection from the most recent 10 numbers.	P. 2-6	—
	Recall	The last conversation partner can be recalled by pressing the [# / ▲] key regardless of whether the call was made or received. Only the AN-8000MS/8500MS permits selection from the most recent 10 numbers.	P. 2-7	—
	Voice calling	Holding down the Push-to-talk key while making a call by means of a continuous call tone permits a voice calling to be made to the called station. The voice calling reverts to the original continuous tone call when the Push-to-talk key is released.	P. 2-7	—
	Group call	When a station is assigned to a call group, if the station is called, all stations within that group are simultaneously called by a continuous call tone regardless of their call receiving mode settings. If any one of the stations within the group responds, calls to the other stations stop.	P. 2-8	P. 5-48 P. 5-52
	Master station call	The pre-programmed master station can be called by pressing the door station's call button.	P. 2-6	P. 5-50 P. 5-55
Incoming Call Selection	Automatic connection	Incoming calls are automatically connected after a brief call tone (1 second) or without a call tone.	P. 2-8	P. 5-48 P. 5-52
	Continuous call	Calls continue with a continuous call tone (or without a call tone) and a status indicator continuously flashes as long as no response is made.	P. 2-8	P. 5-48 P. 5-52

Function		Description	Reference page	
			Operation	Setting
Speed Dialing	Auto-dialing (AN-8000MS/8500MS only)	The dial operation (up to 20-digit numbers) programmed into the station's auto dialer can be performed by one-touch dialing.	P. 2-9	P. 2-9
	One-touch dialing	The dial operation (up to 20-digit numbers) programmed into the station's [7], [8], [9], [0] or off-hook keys can be called by one-touch dialing.	P. 2-10	P. 2-10 P. 5-50 P. 5-55
Hold	Mic Off	When it is desirable to hold the line during a conversation, if any dialing key ([0] – [9]) is pressed, the microphone is disabled as long as the key is pressed.	P. 2-11	—
	Call hold	Pressing the Hold key during a conversation places the conversation on hold, transmitting a hold tone to both parties. If the Hold key is pressed again, the hold mode is cancelled, and the original conversation is restored.	P. 2-11	—
Call transfer		Current conversations can be placed on hold to call a third party by pressing the Transfer key. The original conversation can be subsequently restored or transferred to the third party after conclusion of the second call.	P. 2-12	—
Automatic Transfer	Group hunting	Calls to a busy station are automatically transferred to another designated station, if group hunting function is set to the called station.	P. 2-14	P. 2-14 P. 5-29 P. 5-46 P. 5-48 P. 5-52
	Absence transfer	When no response is made to a call for a set period of time, the call is automatically transferred to another designated station.	P. 2-16	P. 2-16 P. 5-29 P. 5-46 P. 5-48 P. 5-52
	Call forwarding	Calls to stations are automatically transferred to another designated station without sounding a call tone. Two different modes are available: one is call forwarding, in which calls are manually rerouted to the selected station, and the other is time-based call forwarding, which transfers calls only when the preset time is reached.	P. 2-17	P. 2-17 P. 2-18 P. 5-29 P. 5-46 P. 5-48 P. 5-52
Remote Response		Calls to a station can be answered by pressing the Push-to-talk key of another station, provided both stations are assigned to the same group.	P. 2-19	P. 2-20 P. 5-60
Executive Priority		If a called station is busy, as indicated by a busy tone, pressing the [9] key transmits a short priority call tone, then forcibly terminates the current conversation, allowing the call to go through. Access to priority call operation or refusal of priority calls can be set individually for each station.	P. 2-21	P. 5-48 P. 5-52

Function		Description	Reference page	
			Operation	Setting
Paging	Zone paging	Calls can be made to one of the pre-programmed zones.	P. 2-23	P. 5-57
	Selectable paging	Calls can be made to up to 10 zones of the pre-programmed multiple zones.	P. 2-24	P. 5-57
	All-call paging	Calls can be made simultaneously to all of the pre-programmed zones.	P. 2-25	P. 5-57
Paging Response	Automatic response	Dialing the Paging Response key automatically initiates a response to the paging last received.	P. 2-27	P. 5-29 P. 5-46
	Zone number designation paging	Dialing the number assigned to paging response automatically initiates a response to a next-to-last paging.	P. 2-28	P. 5-29 P. 5-46
Scan Monitor		The station can scan an arbitrary group of pre-programmed stations for auditory monitoring.	P. 2-29	P. 5-51 P. 5-56
Door Remote Control (Only when the AN-8050DS/8540DS is used.)		Door station's contact output can be used to remotely control external equipment such as electronic lock. The contact output terminals can be shorted for a set period of time by the dial operation to perform this function from the master station engaged in conversation with the door station.	P. 2-36	P. 5-29 P. 5-46
Time-Out		The duration of calls, conversations and paging can be limited by pre-programming time intervals (10 – 990 seconds) for individual exchanges, multi interface units or IP stations.	P. 2-21	P. 5-29 P. 5-46
Group Blocking		Arbitrary station groups (up to 31 groups) can be set to permit or disallow calls between groups.	P. 2-22	P. 5-58
Station Speaker Output Setting		Permits adjustment of the station speaker sound volume.	P. 2-4	P. 5-48 P. 5-52
Ambient Noise Control		Automatically measures the ambient noise level of the station and sets the station for proper hands-free conversation.	P. 2-5	—

## 7.2. Multi Interface Unit's Functions

The addition of the AN-8000MI Multi-interface unit makes the following functions available:

Function		Description	Reference page	
			Operation	Setting
External Input Paging		Activating the control input after connecting the Remote microphone or playback components to the Multi interface unit enables broadcasting to the preprogrammed zone(s).	P. 2-26	P. 5-38 P. 5-40
PBX Connection		If the Multi interface unit is connected to the PBX's analog E&M interface, calls or conversations can be mutually made between the AN-8000 system's stations and the PBX's extension telephones or paging calls can be initiated from the PBX extension telephone.	P. 2-30	P. 5-38
BGM		Connecting playback components to the Multi interface unit permits Background music selectable from up to 8 programs to be heard from each station speaker while in standby mode.	P. 2-32	P. 5-29 P. 5-38 P. 5-46
External Equipment Control	One-shot make output	External equipment can be controlled by momentarily closing the Multi interface unit's corresponding contact through operation of the station.	P. 2-33	P. 5-36 P. 5-40 P. 5-48 P. 5-52
	Make/break output	External equipment can be controlled by closing or opening the Multi interface unit's corresponding contact through operation of the station.	P. 2-33	P. 5-40 P. 5-48 P. 5-52
Calling Station Indication/CCTV Interlock		Closing the Multi interface unit's contact in synchronization with calls received enables calling station indication or CCTV system control.	P. 2-35	P. 5-29 P. 5-46 P. 5-48 P. 5-52
Door Remote Control		Control of such external equipment as electronic locks can be performed by momentarily closing the Multi interface unit's corresponding contact through operation of the station. Operating the door remote control function at the station in conversation mode closes the Multi interface unit's preset contact output terminal for a specified period of time.	P. 2-36	P. 5-36 P. 5-48 P. 5-52
Contact Bridge		Closes the Multi interface unit's output contact terminal when the input contact terminal is closed.	P. 2-37	P. 5-40
Paging Busy Input		Notifies the busy status of connected external PA paging equipment.	P. 2-37	P. 5-40

## 8. PAGING FUNCTION OUTLINES

There are two types of paging: (1) PA paging by way of external PA equipment and (2) Station paging by way of the station's internal speaker. Both types have access to the (1) zone paging function which pages one zone, (2) the selectable paging function which pages multiple selected zones, and (3) the all-call paging function which pages all zones simultaneously.

### 8.1. Paging Types

#### 8.1.1. PA paging

Connecting PA equipment to the AN-8000EX exchange's or AN-8000MI multi interface unit's output terminal permits PA paging to be made by dial operation at the station.

#### 8.1.2. Station paging

Performing dial operation at a station permits paging to be made to other stations' internal speakers. When paging is made to stations engaged in conversation, its behavior depends on the following priority modes, either of which can be selected: "Paging priority" that puts the busy stations on hold and allows them to be paged, and "Conversation priority" that allows the paging to go through except the busy stations. Use the supplied AN-8000 Software program to perform the mode setting.

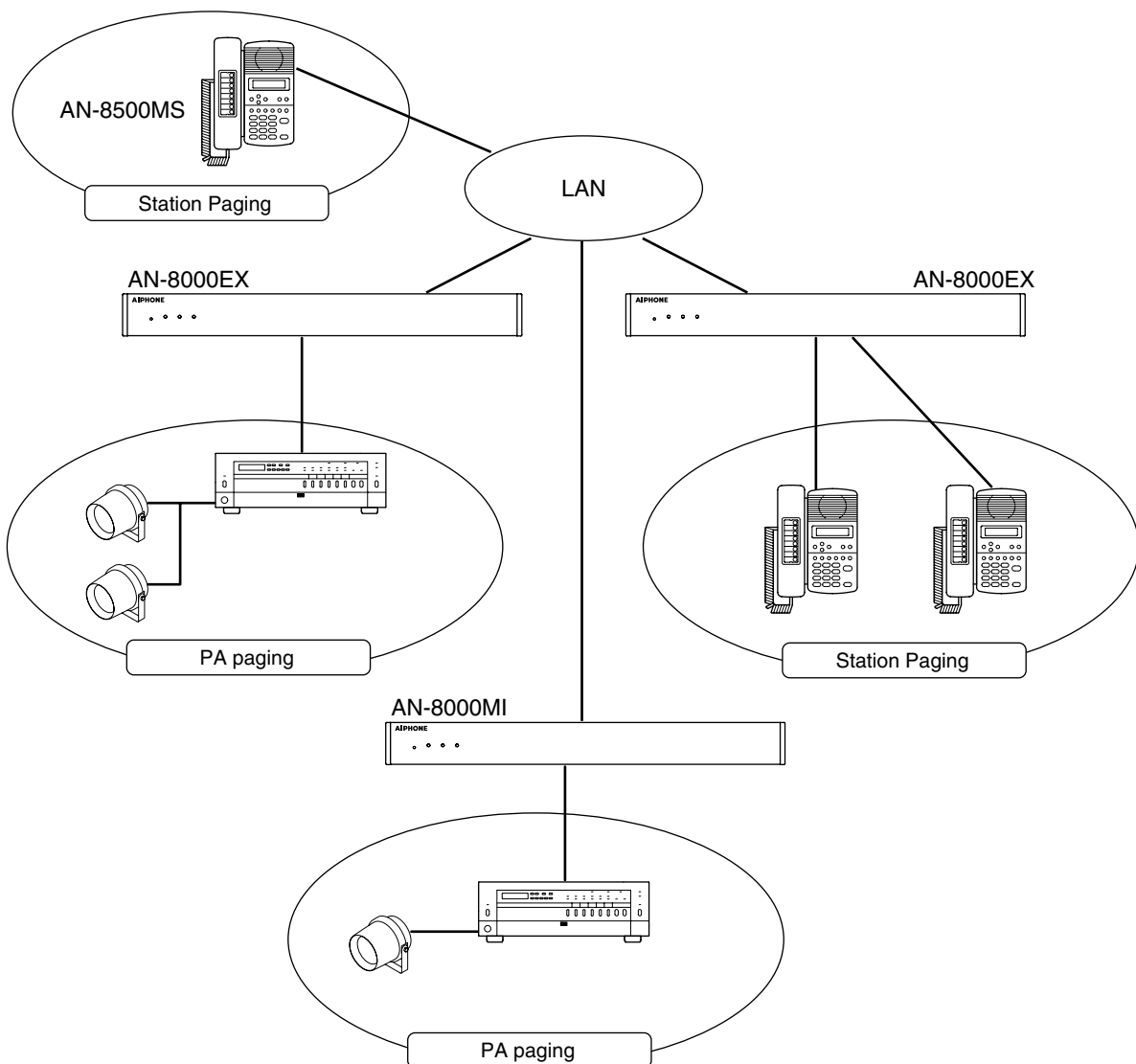



## 8.2. Paging Functions

### 8.2.1. Zone paging

Calls can be made to one of the pre-programmed zones. For PA paging, assign a PA paging output to the zone number. For station paging, assign a station to the zone number. One of the following three settings can be selected: PA paging only, station paging only, or a combination of PA paging and station paging. Use the supplied AN-8000 Software program to perform the mode setting. There are no limitations of the number of stations that can be programmed nor the number of PA paging output.

### 8.2.2. Selectable paging

By performing dial operation at the station, paging can be made to up to 10 zones of the pre-programmed multiple zones.

### 8.2.3. All-call paging

Calls can be made simultaneously to all of the pre-programmed zones

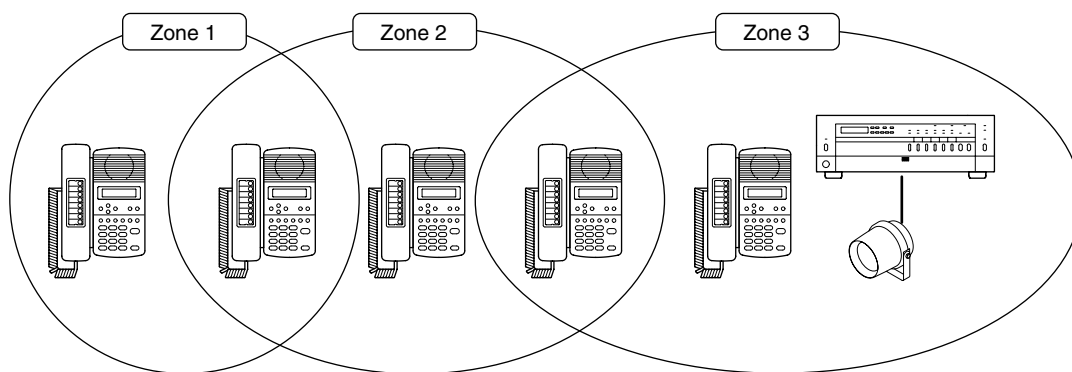

## 8.3. Station Paging Receiving Mode

The station that receives Station Paging operates in either Conversation priority mode or Paging priority mode as described below.

Use the supplied AN-8000 software for the mode setting.

### 8.3.1. Conversation priority mode

- When a paging is made, the station in standby mode receives it. If it is engaged in conversation or dialing, it does not receive the paging.
- If paged during a conversation with another station in the same zone, the paged station receives the paging and the conversation is placed on hold. If the conversation partner belongs to a different zone, a holding tone is transmitted while the conversation is placed on hold.

#### Note

Dialing is possible even while receiving a paging.

### 8.3.2. Paging priority mode

- When a page is made, the station in standby mode receives it. If paged during a conversation, the paged station receives the page without terminating the current conversation, while a holding tone is transmitted to the conversation partner during a conversation between paging and paged parties if the paging station does not belong to the same paging zone.
- When the station being paged receives a call from another station, the paged station becomes busy and maintains the paging. When the station is paged during a conversation and the paging is still connected even after conversation completion, the paging is put through to the station.

#### Note

Dialing is impossible while receiving a page. (Paging response cannot be performed at a paging receiving station, either.)

## 8.4. Responding to Paging

If the paged party responds at a station, the paged party can be put through to the paging party. The following two response modes are available. Use the supplied AN-8000 Software program to set either mode.

### 8.4.1. Automatic response

If the paged party dials the number assigned to paging response, the paging party who initiated the paging last is called and put through to the paged party.

To respond to the paging, use the station assigned to the paged zone. Use this mode when each paging zone is independent. When using external PA speakers, their zones must match those of master stations.

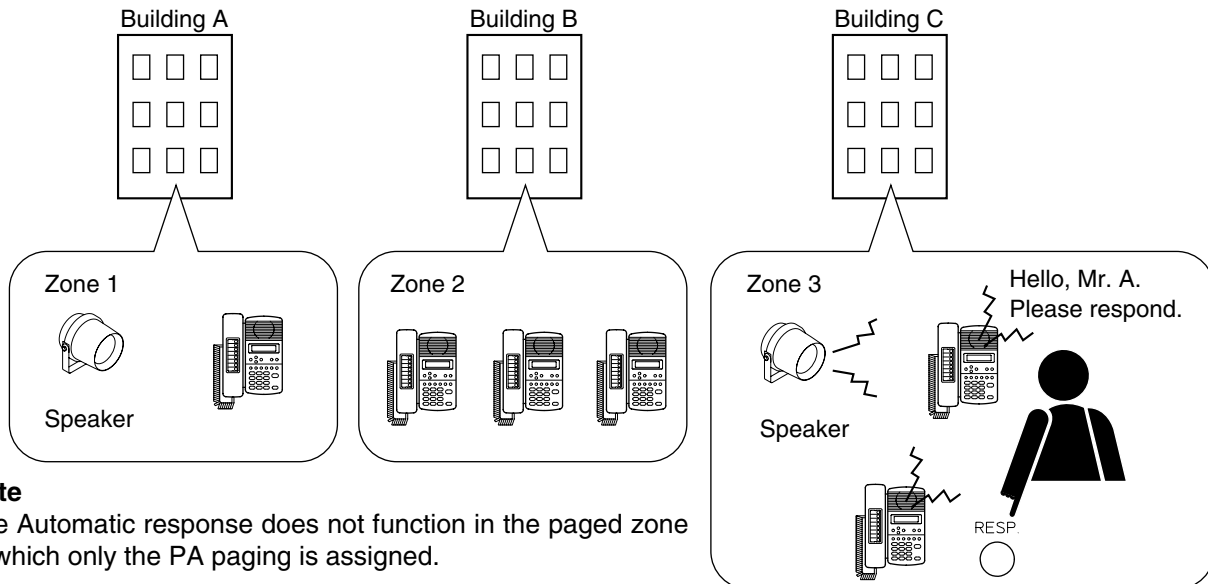

**Note**

The Automatic response does not function in the paged zone to which only the PA paging is assigned.

### 8.4.2. Zone number dialing

When making a paging, the paging party notifies the paging zone to use, and the paged party dials the designated zone number when responding. If the paged party responds dialing the designated zone number, the paging party who made the paging to the designated zone last is called and put through to the paged party.

Use this mode in locations where broadcasts from multiple zones can be heard or if only the PA Paging is used. To respond to the paging, use the station assigned to the paged zone. Any station can also respond to the paging as long as it is connected to the same exchange as the station assigned to the paged zone or the PA paging output are connected to.

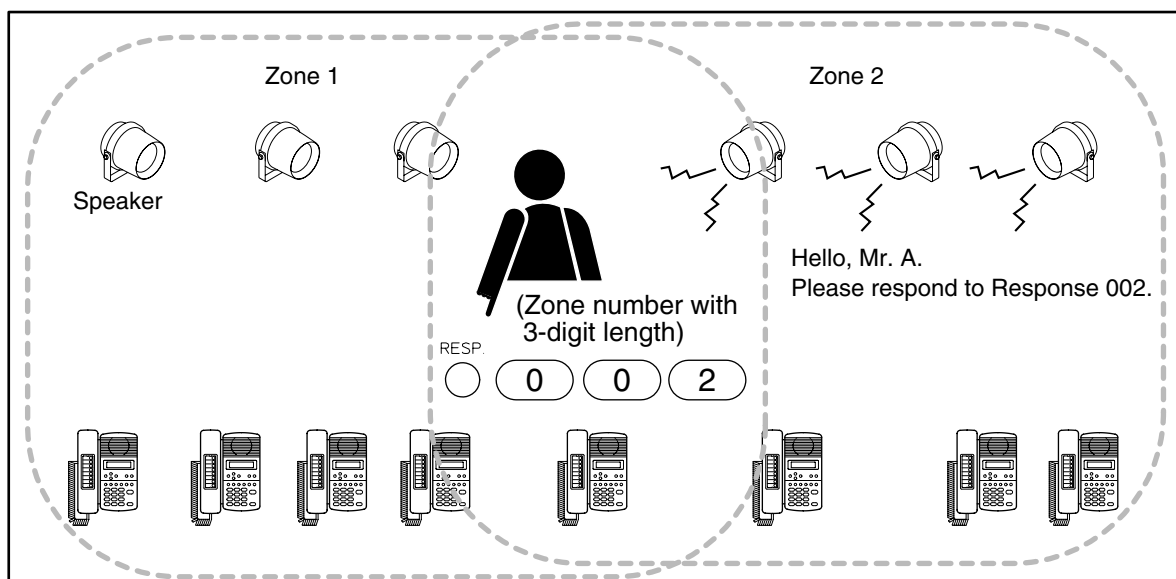

## 9. MULTI INTERFACE FUNCTION OUTLINES

Functions that are available with the use of the AN-8000MI Multi interface unit are described below.

### 9.1. External Input Paging

Microphone announcements or background music can be broadcast to any desired channel by connecting a Remote microphone or playback components to the AN-8000MI unit.

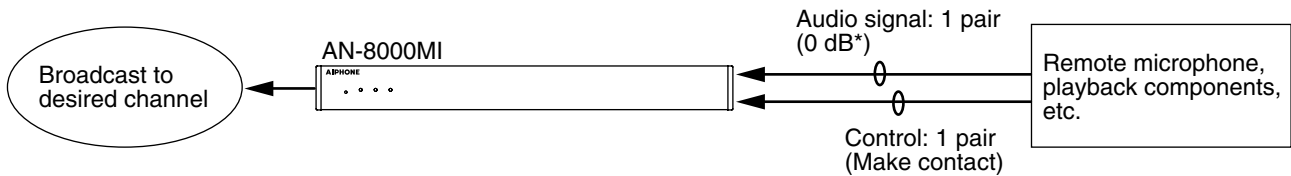

### 9.2. PA paging

Connecting PA equipment to the AN-8000MI multi interface unit's output terminal permits PA paging to be made by dial operation at the station.

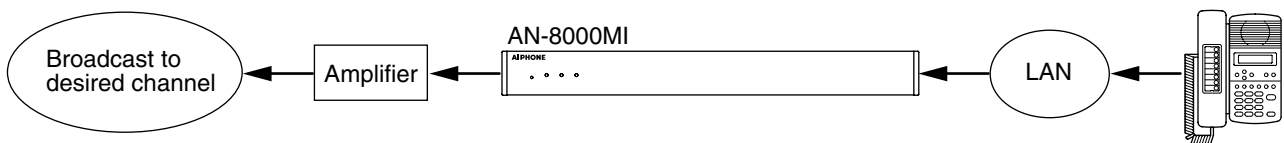

### 9.3. PBX Interface (E and M Interface)

Connecting the AN-8000MI unit to a PBX permits conversations to be made between the intercom station and the telephone, or paging calls to be initiated from the telephone. The AN-8000MI is connected to a standard PBX analog E&M interface using 3 pairs of cables per line. Since the ground return method is employed for the installation of the system connecting between the trunk and the AN-8000MI, use grounding or connect the grounding cable separately.

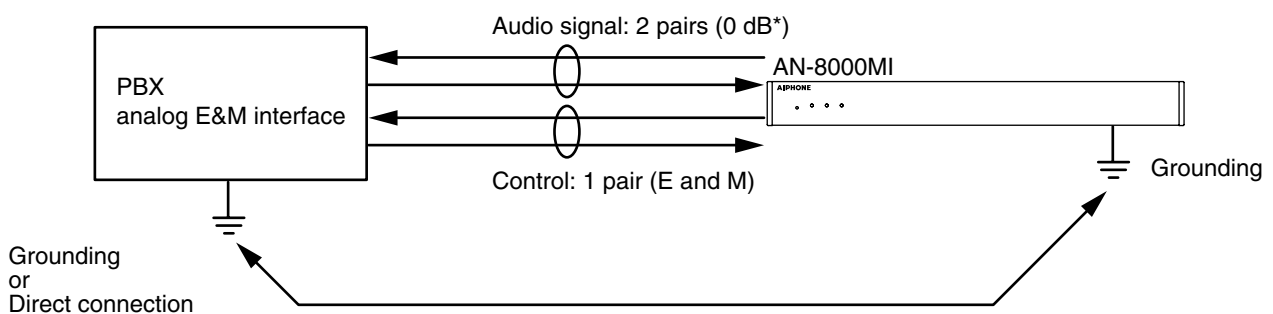

\* 0 dB = 1 V

## 9.4. BGM

Background music can be transmitted to the station speakers in standby mode by connecting the AN-8000MI unit to musical playing equipment. Any BGM program can be selected from 8 channels at each station.

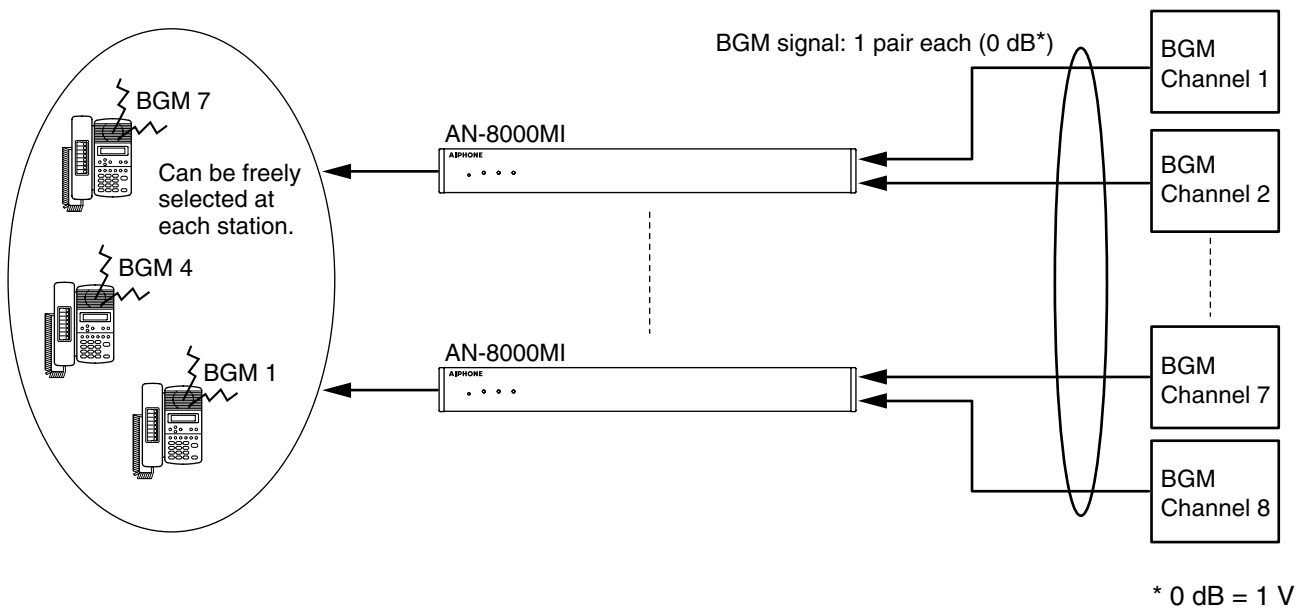

### Note

Since BGM is lower than conversations and paging in priority, BGM may be interrupted at a BGM-broadcast station even if the station performs no operation when other station makes a call or paging with all speech links busy.

## 9.5. Contact Input and Output Functions

The following functions can be realized by using the AN-8000MI's contact input and output.

### 9.5.1. External equipment control

External equipment can be controlled by a one-shot make signal or a make/break signal provided at the AN-8000MI's contact output through either interlock with received calls or station operation. Such control includes door remote control, calling station indication control, and hospital waiting status indication control.

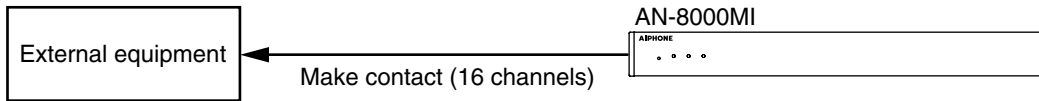

### 9.5.2. Contact bridge function (external contact interlock)

Contact signals can be transmitted by way of a network.

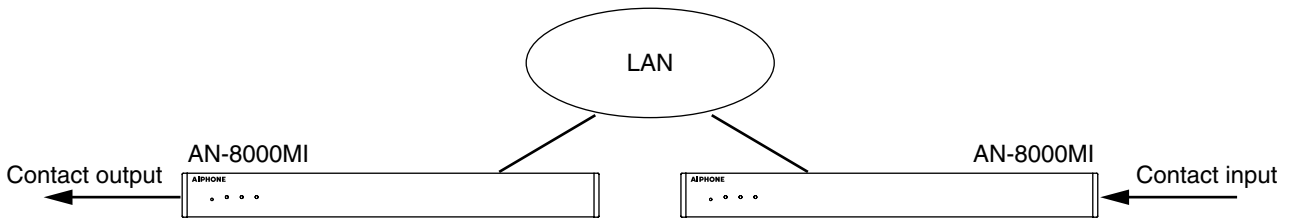

### 9.5.3. Paging busy input

Busy status data from an airport broadcast system or similar large sound systems can be received when the AN-8000MI is interlocked with such systems, allowing important information to be accurately transmitted.

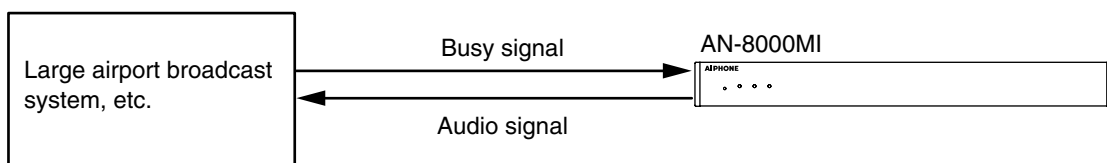

# ***Chapter 2***

---

## ***FUNCTIONS AND OPERATION***

This chapter describes the system functions and operation of the AN-8000 Series Network Intercom System.

## 1. BASIC USAGE

Operation is the same for both the stations connected to the exchange and the IP stations connected to a LAN.

### 1.1. Calling from a Master Station

**Step 1.** Dial the number of the station to be called.

- Dialing from a master station is possible with its handset either lifted or in place.

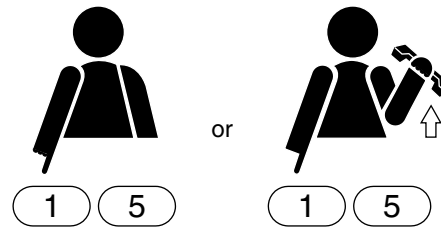

The calling station's internal speaker sounds an audible call tone (heard in the handset speaker if the handset is lifted).

When a busy tone is heard, wait till the line becomes free, and you are automatically connected to the called party.

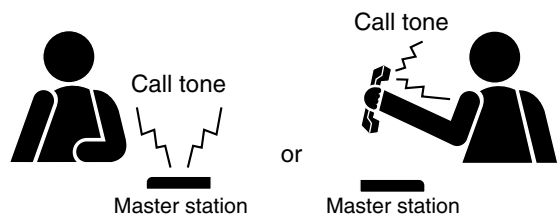

**Step 2.** Conversation can begin when the calling tone stops and the called party responds.

- When the called station is set to Automatic connection mode\*, the calling party is automatically connected after a brief call tone and conversation can begin.
- When the called station is set to Continuous call tone mode\*, a continuous call tone sounds until the called station responds, after which conversation can begin.



**Step 3.** When conversation is finished, press the Clear key or replace the handset.

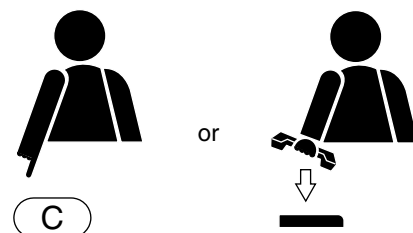

\* Use the supplied AN-8000 Software program to perform Automatic connection mode/Continuous call tone mode setting. (Refer to [p.5-48, 5-52.](#))

#### Note

If the system has been set for call time-out or conversation time-out, the call or conversation automatically stops after the specified time limit. The specific length of this time-out (in 10-second units between 10 and 999 seconds) is preprogrammed into individual exchanges or IP stations using the supplied AN-8000 software (Refer to [p. 5-29, 5-46.](#))

## 1.2. Calling from a Door Station

**Step 1.** Press the call button to call the pre-programmed master station.



The calling station's internal speaker sounds an audible call tone.

- If the door station is not set to door station mode, a busy tone is heard when the called master station is busy. When a busy tone is heard, wait till the line becomes free, and you are automatically connected to the called party.

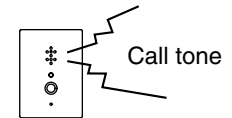

### [When the door station is set to door station mode]

The call tone sounds only once regardless of the called station's connection mode settings.

When no response is made to a call within 30 seconds, the call automatically stops, as the call timeout is limited to 30 seconds in this mode.

### [When the door station is not set to door station mode]

When the called master station is set to Automatic connection mode, the calling party is automatically connected after a brief tone and conversation can begin.

When the called master station is set to Continuous call tone mode, a continuous call tone sounds until the called station responds, after which conversation can begin.

### Note

Calls cannot be terminated at the door station.

**Step 2.** Conversation can begin when the called party responds.

### [When the door station is set to door station mode]

Conversation automatically terminates in 30 seconds, as the conversation timeout is limited to 30 seconds.

### Tip

This 30-second limit becomes invalid when lifting the handset, or pressing the hold key or transfer key at the master station.

### [When the door station is not set to door station mode]

Conversations are available until the called party at the master station executes the termination operation.

### Note

Conversation cannot be terminated at the door station.

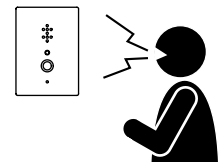

### Notes

- Preprogram the master station to call to.  
Programming can be performed by dialing operation of the multifunctional master station (refer to [p.7-6](#)) or using the supplied AN- 8000 Software program (refer to [p.5-50, 5-55](#)).
- Use the supplied AN-8000 Software program to perform Door station mode setting. (Refer to [p.5-48, 5-52](#).)



## 1.3. Receiving a Call

### 1.3.1. Receiving a call at the master station

#### Step 1. Responding to a Received Call.

**1-1.** If the called station is set to Automatic connection mode\*, the call tone sounds only once, after which the calling party's voice is heard immediately through the internal speaker. Respond by speaking into the station microphone or the handset.

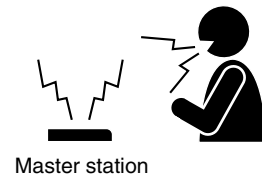

**1-2.** If the called station is set to Continuous call tone mode\*, press any key for hands-free conversation or lift the handset for handset conversation.

**Tip**

If a headset is connected to the called station, the station is called by a continuous call tone regardless of the call receiving mode setting. In this case, the continuous call tone is also heard from the station speaker.

Lifting the handset creates a handset conversation.

[Example]

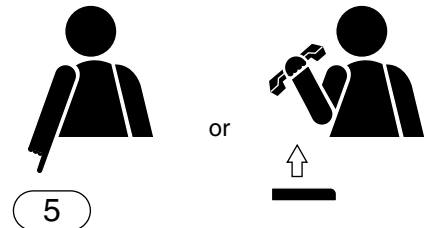

**Step 2.** When conversation is finished, press the Clear key or replace the handset.

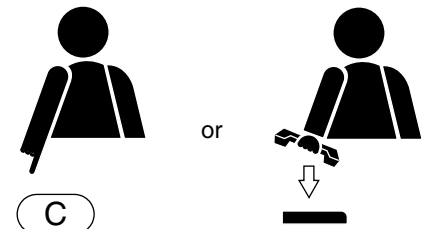

\* Use the supplied AN-8000 Software program to perform Automatic connection mode/Continuous call tone mode setting. (Refer to [p.5-48, 5-52.](#))

### 1.3.2. Receiving a call at the door station

When receiving a call from the master station, the call tone sounds only once, after which the calling party's voice is heard immediately through the internal speaker. Respond by speaking into the door station.

Conversation termination operation cannot be executed at the door station.

Conversation can be terminated by the termination operation at the master station or after the preset time limit.

## 1.4. Station Speaker Volume

The volume of the master station speaker can be preset (in five 3-decibel increments) using the supplied AN-8000 software program, however it can also be adjusted at the station.

- Pressing the [ #/▲ ] key during conversation increases the volume.

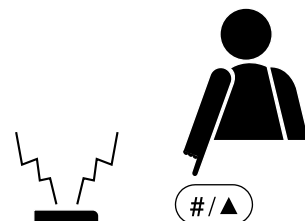

- Pressing the [ \*/▼ ] key during conversation decreases the volume.

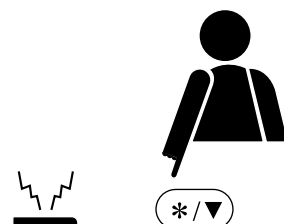

**Note**

The resulting volume level will be maintained even after conversation is finished.

## 2. CONVERSATION FUNCTIONS AND OPERATION

### 2.1. Conversation

#### 2.1.1. Hands-free conversation

Permits conversations to be made without holding the handset when another party is called or when a call is received in automatic connection mode.

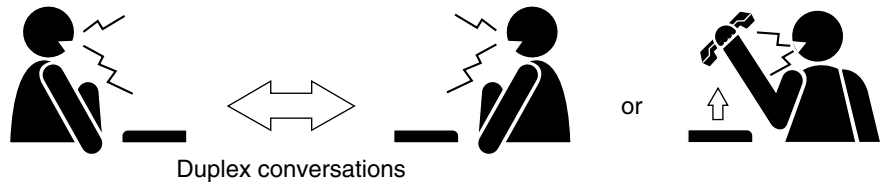

#### [Ambient Noise Level Measurement]

The master station has a function to measure ambient noise level at its installation site, automatically making the internal setting for proper hands-free conversation. (Since IP stations are so designed as to always perform proper hands-free conversation, they need not make the measurement.)

If a malfunction of hands-free conversation such as one-way conversation from the station in high ambient noise area occurs, recalibrate by re-measuring ambient noise as follows.

**With the handset in place, press the [\*/▼] key and then the [#/▲] key to begin ambient noise level re-measurement.**

"Re-measuring" will appear on the LCD (if the AN-8000MS station is being used).

After about five seconds, a confirmation tone sounds to indicate that ambient noise re-measurement has been completed.

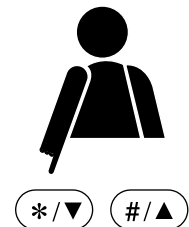

#### Tip

The master station automatically measures the ambient noise level when the Exchange is powered up or the station is connected to the line. During the measurement, the station's status indicator flashes and the dial operation cannot be performed.

#### [Operation when both stations are engaged in hands-free conversation]

In "hands-free to hands-free" conversation between both stations, simultaneous two-way conversation is established by way of an echo canceller\* and voice switch employed in each station.

During this conversation, station's internal settings (parameters relating to the condition of sound reflection) are constantly updated in response to the change in sound collected by the built-in microphone, allowing for optimum hands-free conversation.

When both stations make hands-free conversation after either one has been moved in a new environment or the environment surrounding the station has significantly changed, this may cause acoustic feedback. In this case, continue the conversation and the situation will soon return to the normal condition.

If acoustic feedback cannot be removed, adjust the microphone sensitivity and speaker output volume of the station.

#### Note

Use the supplied AN-8000 Software program (refer to [p. 5-48](#), [5-52](#)) to set the microphone sensitivity and speaker output volume.

It is possible to set the master station's speaker output volume at the station. (Refer to [p. 2-4](#).)

\* An echo canceller is used to eliminate acoustic feedback caused when the voice outputs from the station's speaker are picked up by the same station's microphone. As acoustic feedback cannot be eliminated thoroughly, the echo canceller is usually used in conjunction with a voice switch.

#### 2.1.2. Handset conversation

Calls can be made or received by lifting the handset.

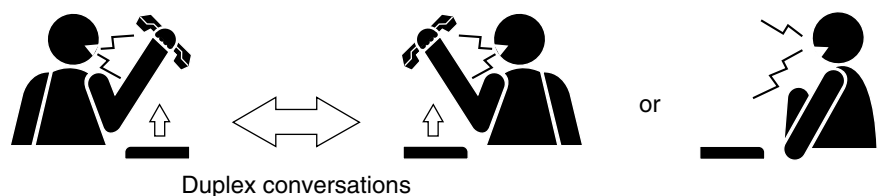

### 2.1.3. PTT conversation

This function makes announcements and conversations possible to areas with a high ambient noise level. Pressing the Push-to-talk key during a conversation enables one-way conversation from the party who pressed the Push-to-talk key. Conversation flow is reversed when the key is released. When both parties have pressed the Push-to-talk key, the party who pressed the button last is given precedence to speak.

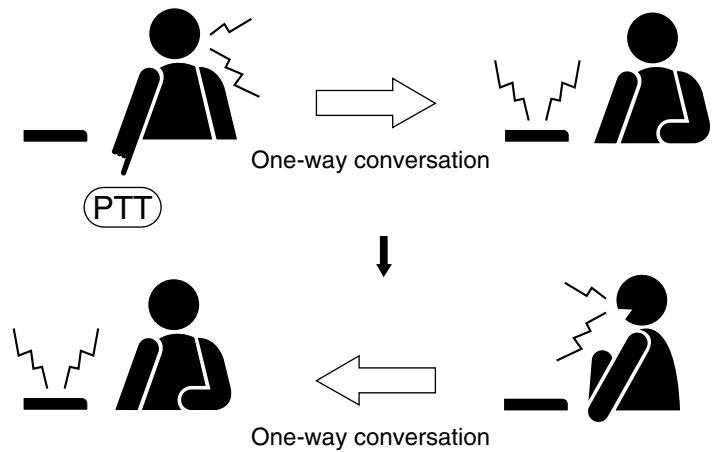

## 2.2. Calling

### 2.2.1. Individual calls

- The desired party can be called by dialing its station number.  
(The desired party can be called by dialing its station number without lifting the handset.)
- Conversation can begin when the called party responds and the call tone stops.
- A busy tone indicates that the called party is already engaged on another line.  
Connection to the called party will occur as soon as the busy line is freed.

### 2.2.2. Master station calls

The pre-programmed master station can be called by pressing the door station's call button.

#### Note

Preprogram the master station to call to.

Programming can be performed by dialing operation of the multifunctional master station (refer to [p.7-6](#)) or using the supplied AN-8000 Software program (refer to [p.5-50, 5-55](#)).

### 2.2.3. Redialing

Pressing the Redial key automatically redials the last dialed number.

Only the AN-8000MS Multifunctional Master Station and the AN-8500MS IP Multifunctional Master Station permit selection from the most recent 10 numbers dialed.

#### Tip

Keys to be registered into the Redial key are the Dial keys (12 keys), the Paging key, and the Function key.

#### When using the AN-8010MS/8011MS/8020MS/8031MS:

Press the Redial key to automatically redial the last dialed number (individual call, paging, etc.)

[Example when dialing the paging last]

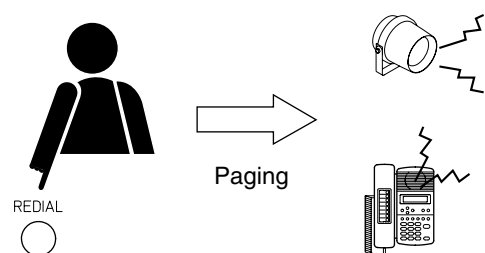

**When using the AN-8000MS/8500MS station:**

**Step 1.** Press the Redial key to display the most recently dialed numbers on the display.



[Example]



**Step 2.** Use the Up and Down arrow keys to display the desired dial number. Pressing the Down arrow key displays the last ten numbers dialed in reverse chronological order. They are numbered 0 – 9 from top to bottom.



**Step 3.** Press either the Select or Redial key to perform the dial operation indicated on the display (individual call, paging, etc.).

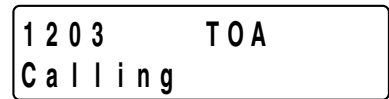

**2.2.4. Recall**

The last conversation partner can be recalled by pressing the [ #/▲ ] key regardless of whether the call was made or received. Only the AN-8000MS Multifunctional Master Station and the AN-8500MS IP Multifunctional Master Station permit selection from the most recent 10 numbers.

**When using the AN-8010MS/8011MS/8020MS/8031MS:**

Press the [ #/▲ ] key to recall the last conversation partner regardless of whether the call was made or received.

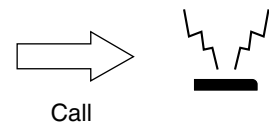

(The last conversation partner)

**When using the AN-8000MS/8500MS:**

**Step 1.** Press the [ #/▲ ] key to display the recent dial data of the conversation partners regardless of whether the call was made or received on the display.



[Example]



**Step 2.** Use the Up and Down arrow keys to display the desired dial number. Pressing the Down arrow key displays the last ten numbers dialed in reverse chronological order. They are numbered 0 – 9 from top to bottom.

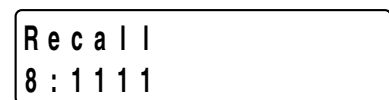

**Step 3.** Press either the Select or [ #/▲ ] key to perform the dial operation indicated on the display.



**2.2.5. Voice callings**

A voice call can be made to the called station while making a call by means of a continuous call tone.

- Voice a call to a called party by pressing the Push-to-talk key as the continuous call tone sounds. The call tone stops as long as the Push-to-talk key is pressed, enabling the called party to hear your voice.
- The original continuous call tone resumes as soon as the Push-to-talk key is released.

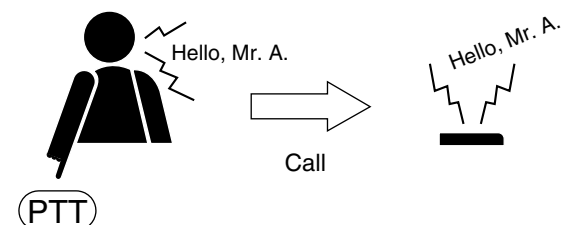
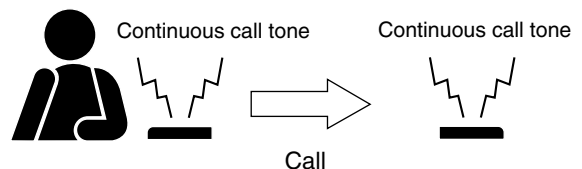

### 2.2.6. Group calls

- When a station is assigned to group call member station, if the station is called, this station (representative station) and all member stations are simultaneously called by a continuous call tone regardless of their call receiving mode settings.
- Even when the representative station is busy, all of the associated member stations within the same group are called by means of a continuous call tone. This continuous call tone stops when any one of the associated stations responds to the call.

#### Notes

- Use the supplied AN-8000 Software program to perform the group call member station setting. (Refer to [p. 5-48, 5-52](#))
- The AN-8050DS Door Station and AN-8540DS IP Door Station cannot be assigned to the group call representative station nor member station.

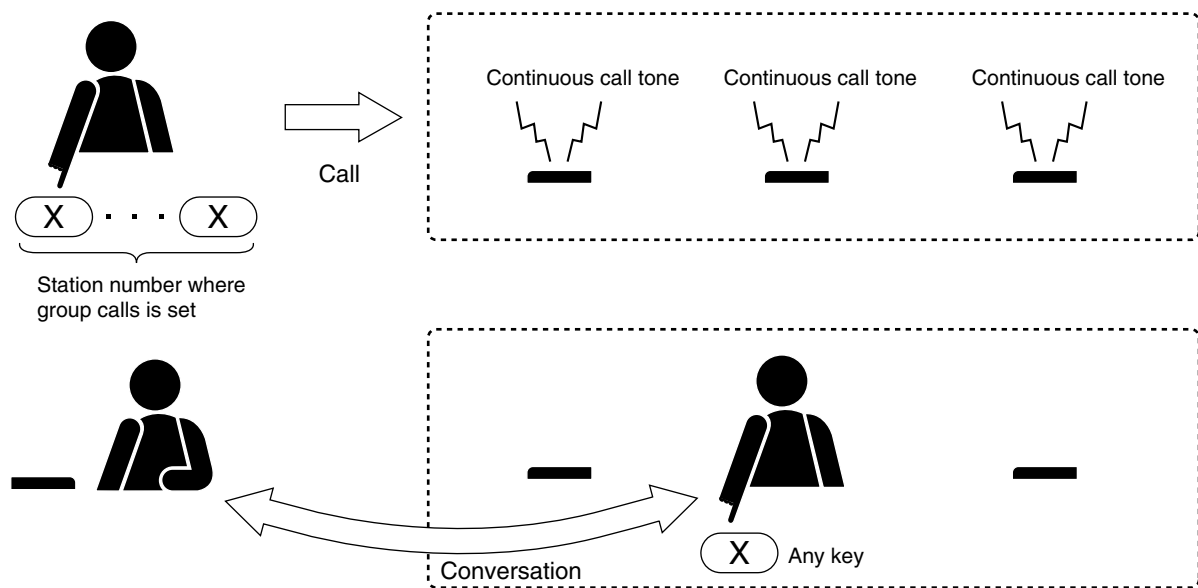

## 2.3. Setting Call Receiving Modes

Call receiving modes, and call tone on/off can be selected for each station.

Use the supplied AN-8000 Software program to perform the setting. (Refer to [p. 5-48, 5-52.](#))

### 2.3.1. Automatic connection

Incoming calls are automatically connected after a brief call tone (about 1 second) or without a call tone. When a call is received, the status indicator flashes red. It lights red continuously when a conversation begins. Lifting the handset creates a handset conversation.

### 2.3.2. Continuous call

Calls continue with a continuous call tone (or without a call tone) and a status indicator continuously flashes as long as no response is made. When a call is received, the status indicator flashes red. It lights red continuously when a conversation begins.

Lifting the handset to respond to a call creates a handset conversation.

Pressing any key to respond to a call creates a hands-free conversation (one-touch key response).

#### Note

The AN-8050DS Door Station and AN-8540DS IP Door Station cannot be set for the continuous call function.

## 2.4. Speed Dialing

### 2.4.1. Auto-dialing (AN-8000MS/8500MS only)

The dial operation (up to 20-digit numbers) programmed into the station's auto dialer can be performed by one-touch dialing.

- Auto Dial keys can be programmed individually at each station.
- The contents programmed into each Auto Dial key can be confirmed at each station.

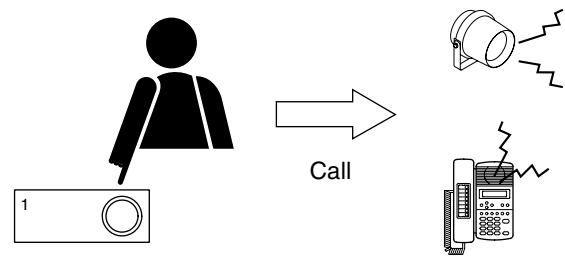

#### [Programming]

**Step 1.** Press the Menu key to set the display to Menu mode.

MENU



→1: Auto-dialing  
2: Line monitor

**Step 2.** Press the Select key to set the display to auto-dial programming mode and display the data already programmed into Auto Dial key 1.

SELECT



→Auto-dial 1:

#### Tips

- Use the Left and Right arrow keys to scroll the display of programmed numbers with more than 15 digits.
- Since there are no factory program settings, the display is initially blank.

**Step 3.** Select the desired Auto Dial key by pressing the corresponding Auto Dial key directly or moving the cursor using the Up and Down keys.



or

[Example]

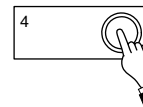

**Step 4.** Press the Select key to allow the contents programmed into the selected Auto Dial key to be changed.

SELECT



Auto-dial 4:  
→

**Step 5.** Enter new programming contents using the Dial keys (12), Paging key, Paging Response key, Hold key, Transfer key, and/or Function key. Entering a number longer than 15 digits causes the screen to scroll.

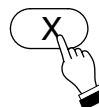

Auto-dial 4:  
→2004

**Step 6.** Press the Select key to enter the number into the program of the selected Auto Dial key. To continue programming other keys, return to Step 3 and repeat the process.

SELECT



→Auto-dial 4:  
2004

**Step 7.** Press the Menu key to return the screen to the normal (standby) mode.

MENU



10:08 AM  
2000

### 2.4.2. One-touch dialing

The dial operation (up to 20-digit numbers) programmed into the station's [7], [8], [9], [0], or [Off-Hook\*] keys can be called by one-touch dialing.

\* The action to lift up the handset.

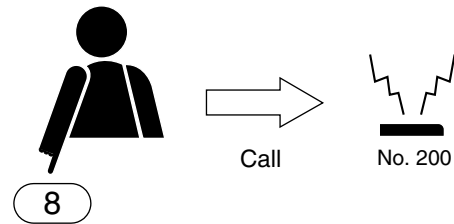

#### Notes

- Perform one-touch dial programming when using the external dial input terminal on the AN-8031MS.
- The one-touch programming can be performed either by dialing operation (see below) or using the supplied AN-8000 Software program. (Refer to p. 5-50, 5-55.)

#### [Programming]

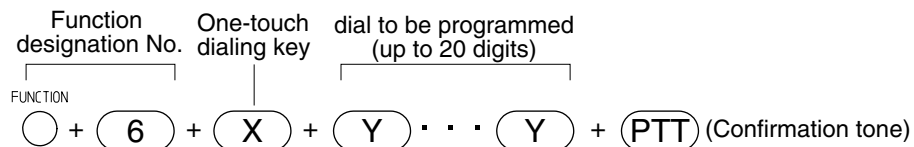

#### [Erasure]

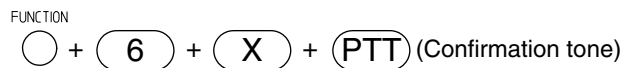

#### Tips

- The key X above represents the [7], [8], [9], [0], or Push-to-talk keys, which are used for one-touch functions.
- Enter one-touch dialing programming (the key Y above) using the Dial keys (12), Paging key, and/or Function key.

**[Example] Programming [7] key for function designation number of Call forwarding.**

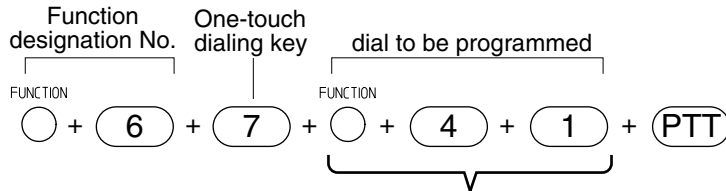

(Example) Function designation number of Call forwarding

- Press the Push-to-talk key when enabling the Off-Hook function for one-touch key operation.

**[Example] Programming and erasing of station [1][2][3] for the Off-Hook function.**

#### [Programming]

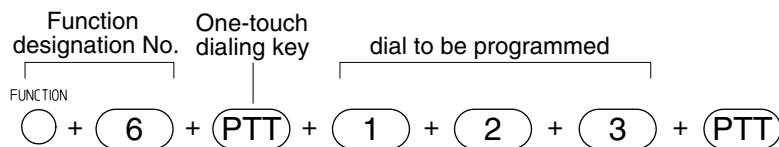

#### [Erasure]

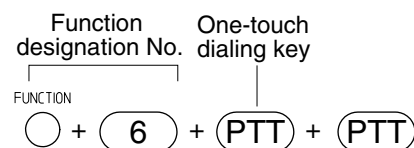

#### Note

The programmed contents by dialing operation are automatically saved into the exchange or IP stations at midnight every day. If the exchange or IP station is turned off before completion of save, the state returns to the contents that were programmed before power-off.

## 2.5. Hold

### 2.5.1. Mic off

Disabling the microphone during a conversation places the line on hold.

#### [Mic off]

Hold down any key of [0] through [9] continuously during a conversation.

[Example]

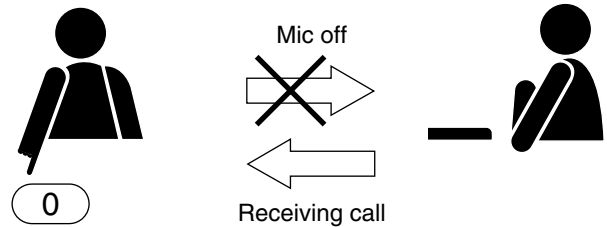

#### [Mic off release]

If the key hold down is released, the original conversation is restored.

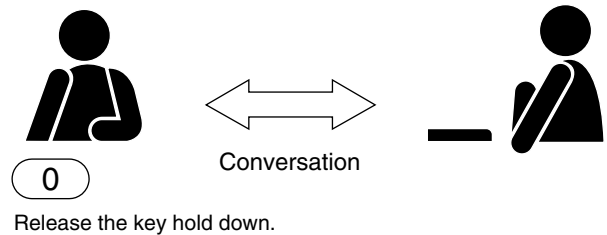

### 2.5.2. Call hold

Conversation during a conversation can be placed on hold.

#### [Hold]

Pressing the Hold key during a conversation placed the conversation on hold, transmitting a hold tone to both parties.

If the handset is replaced with the key held down, the conversation is not terminated.

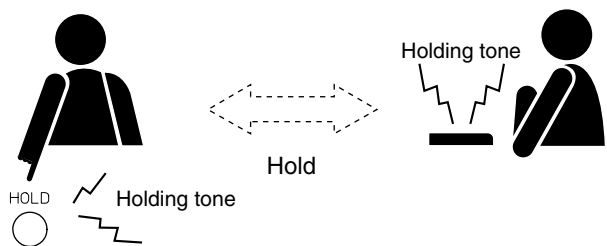

#### [Hold release]

If the Hold key is pressed again, the hold mode is cancelled, and the original conversation is restored.

If the call is on hold with the handset on hook, only lifting the handset cancels the hold mode.

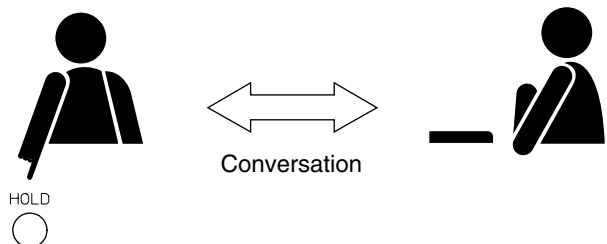



## 2.6. Call Transfer

During a conversation, either party can call another station to speak with a third party (temporarily placing the original conversation partner on hold) and then either return to the original conversation or transfer the conversation with the third party to the original conversation partner.

**Step 1.** Press the Transfer key during a conversation to place the current conversation on hold and transmit a holding tone to the other party.

**Step 2.** Dial the third party's station number, for example [6][3]. If the third party responds, the first party can speak with the third party while keeping the original conversation on hold.

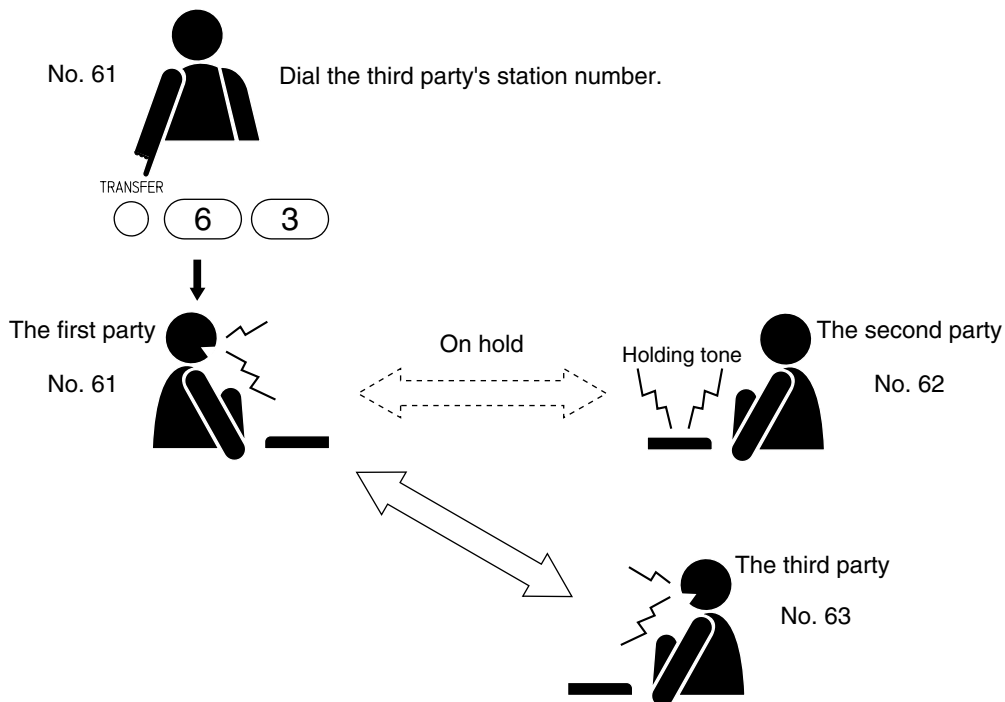
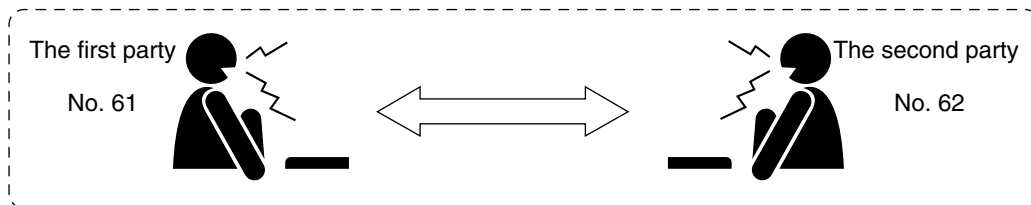

After completing the conversation with the third party, the first party can transfer the original conversation to the third party or return to the original conversation, as described next.

**[Transferring calls to a third party]**

**Step 3.** To connect the third party to the original conversation partner (who has been placed on hold), either press the Clear key or replace the handset. This permits conversation between the second and third parties.

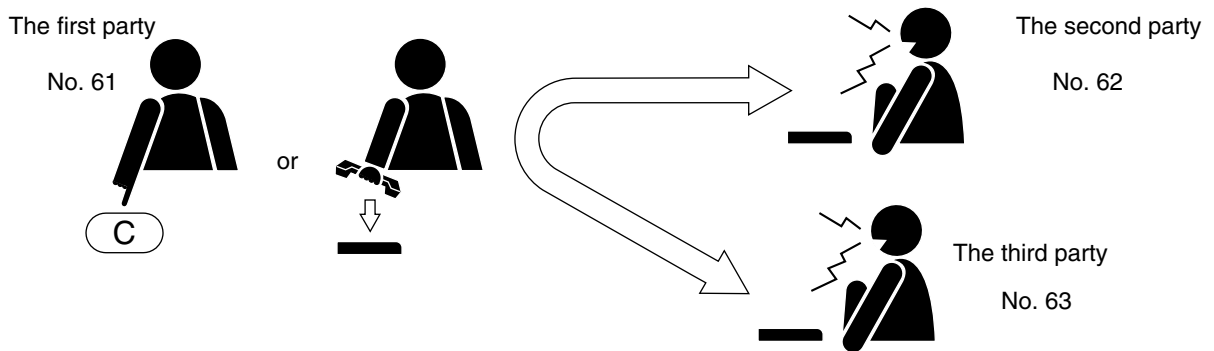

**[Returning to the original conversation]**

**Step 4.** To return to the original conversation without transferring it to the third party, press the Transfer key again. The original two-way conversation is restored.

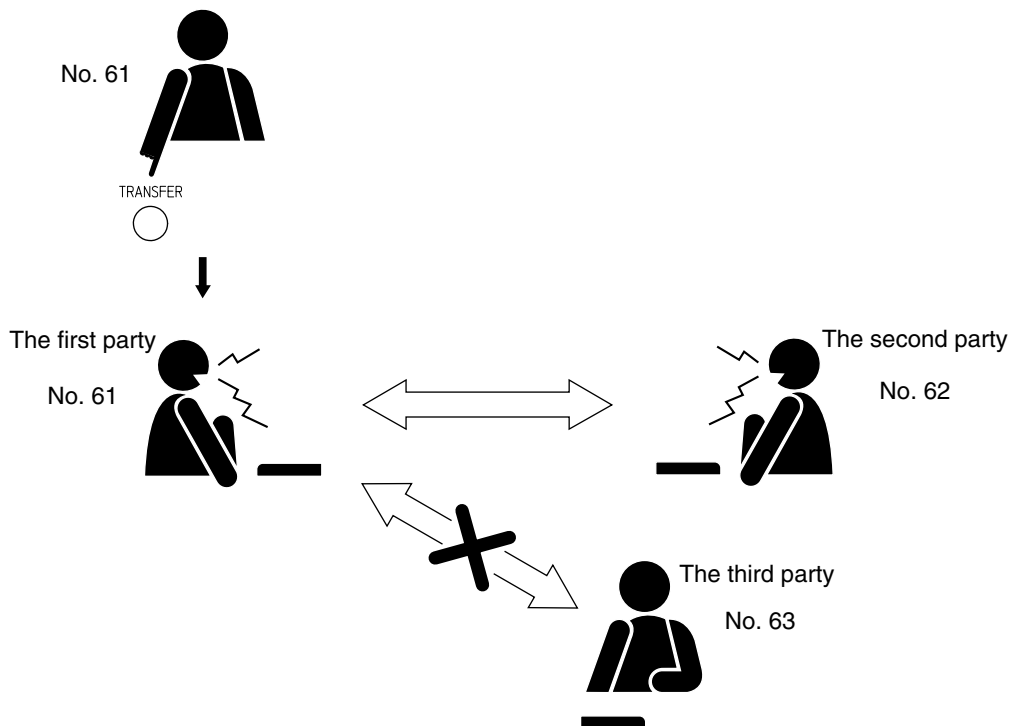

**Tip**

Even if the first party does not press the Transfer key, if the third party either presses the Clear key or replaces the handset of its station, the original conversation is restored.

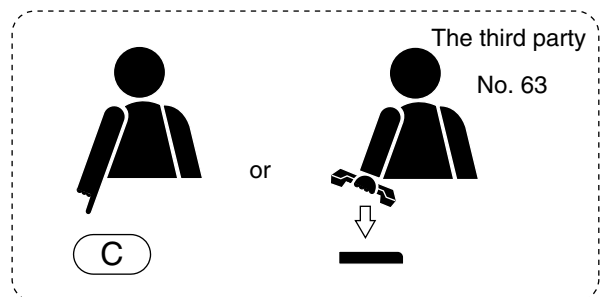

## 2.7. Automatic Transfer

### Note

Calls cannot be automatically transferred to the station connected via the multi interface unit.

### 2.7.1. Group hunting

Calls to a busy station are automatically transferred to another designated station.

This Group hunting function also applies to the call transfer (p. 2-12) performed during conversation.

When the designated station to which a call was transferred is busy, the call is automatically transferred to the next designated station, and this continues in series until a free line is found.

### Note

The station to which a call is to be transferred can be set either by dialing operation (see below) or using the supplied AN-8000 Software program. (Refer to p. 5-48, 5-52.)

Use the supplied AN-8000 Software program to enable or disable the Group hunting function. (Refer to p. 5-29, 5-46.)

The station to which a call is to be transferred cannot be designated unless the group hunting function is enabled.

(Example: A call to the station number 62 will automatically be transferred, if 62 is busy, to the next designated station, number 63.)

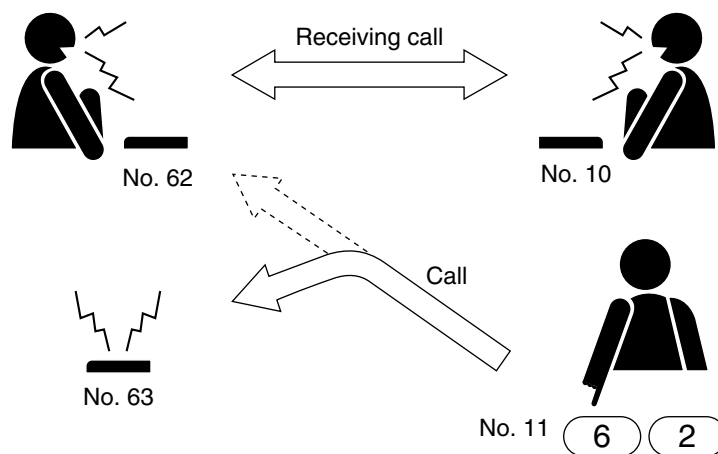

### Notes

Calls are not transferred under the following conditions:

- The designated station is set for Call forwarding.
- The designated station is not in standby mode. (However, even when the designated station is busy, if it is set for Group hunting, the call is further transferred to the next designated station.)
- The station set for Group hunting is called as a representative or its associated member station of the group.

Programming or erasure can be performed at your station.

**[Programming]**       $\text{FUNCTION} \circ + \overbrace{4 \ 5}^{\text{Function designation number}} + \overbrace{X \ \dots \ X}^{\text{Transfer destination station number}} + \#/\blacktriangle \text{ (Confirmation tone)}$

The originally called (your) station number

**[Erasure]**       $\text{FUNCTION} \circ + 4 \ 5 + Y \ \dots \ Y + \#/\blacktriangle \text{ (Confirmation tone)}$

**[Setting example]** Settings can be performed to permit calls to be transferred to designated stations in a cyclical manner.

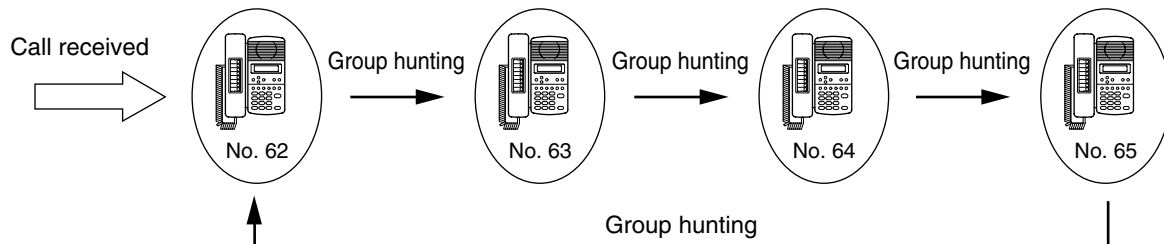

#### Notes

- The station to which a call is to be transferred via multi interface unit cannot be programmed as a transfer destination station.
- The programmed contents by dialing operation are automatically saved into the exchange or IP stations at midnight every day. If the exchange or IP station is turned off before completion of save, the state returns to the contents that were programmed before power-off.

## 2.7.2. Absence transfer

When no response is made to a call to the station for a set period of time, the call is automatically transferred to another designated station.

Calls received during conversation can be transferred. (Refer to p. 2-12.)

The station to which a Absence transfer is to be transferred can be set either by a dialing operation (see below) or using the supplied AN-8000 Software program. (Refer to p. 5-48, 5-52.)

Use the supplied AN-8000 Software program to enable or disable the Absence transfer or to set a calling duration. (Refer to p. 5-29, 5-46.)

The station to which a call is to be transferred cannot be designated unless the Call forwarding function is enabled.

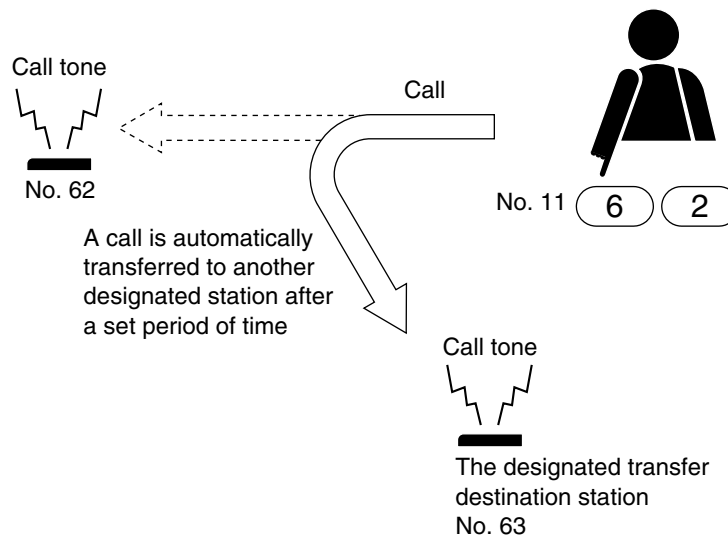

### Notes

Calls are not transferred under the following conditions:

- The designated station is set for Call forwarding.
- The designated station is not in standby mode
- The station set for Absence transfer is called as a representative or its associated member station of the group.

Programming or erasure can be performed at your station.

[Programming] FUNCTION ○ + 4 4 + X . . . X + #/▲ (Confirmation tone)

Function designation number: 4 4  
Transfer destination station number: X . . . X

[Erasure] FUNCTION ○ + 4 4 + Y . . . Y + #/▲ (Confirmation tone)

The originally called (your) station number

### Notes

- The station to which a call is to be transferred via multi interface unit cannot be programmed as a transfer destination station.
- The programmed contents by dialing operation are automatically saved into the exchange or IP stations at midnight every day. If the exchange or IP station is turned off before completion of save, the state returns to the contents that were programmed before power-off.

### 2.7.3. Call forwarding

Calls to stations are automatically transferred to another designated station without sounding a call tone. Two different modes are available: one is call forwarding, in which calls are manually rerouted to the selected station, and the other is time-based call forwarding, which transfer calls only when the preset time is reached. This Call forwarding function also applies to the call transfer (p. 2-12) performed during conversation.

The station to which a Call forwarding is to be transferred can be set either by dialing operation (see below and p. 2-18) or using the supplied AN-8000 Software program. (Refer to p. 5-48, 5-52.)

Use the supplied AN-8000 Software program to enable or disable the Call forwarding function or to set the transfer start/end time. (Refer to p. 5-29, 5-46.)

The station to which a call is to be transferred cannot be designated unless the Call forwarding function is enabled.

#### Note

Calls are not transferred if the station set for Call forwarding is called as an associated member station of the group.

#### [Calls to stations manually set for call forwarding]

Calls to the station manually set for Call forwarding are automatically transferred to the designated station without sounding a call tone.

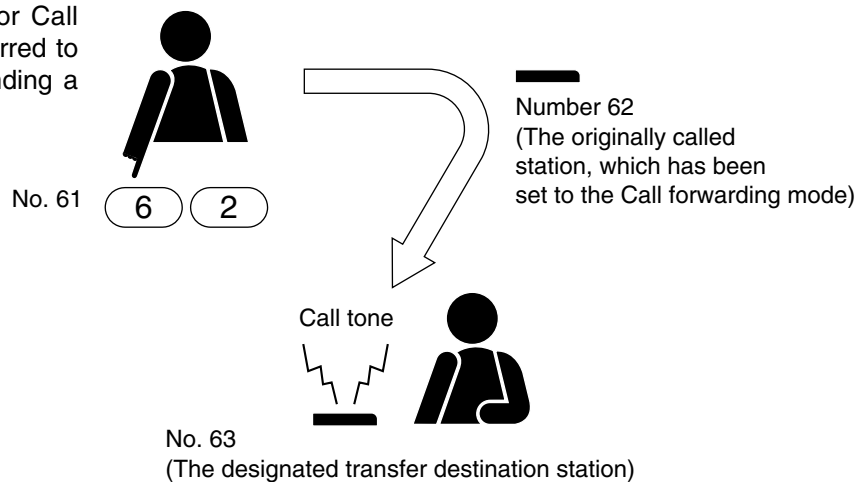

Programming can be performed at your station or the transfer destination station, while erasure at your station.

**[Programming at your station]**

FUNCTION      Function designation number      Transfer destination station number

○ + (4) (1) + (X) . . . (X) + (#/▲) (Confirmation tone)

The originally called (your) station number

**[Programming at the transfer destination station]**

FUNCTION

○ + (4) (2) + (Y) . . . (Y) + (#/▲) (Confirmation tone)

The originally called (your) station number

**[Erasure]**  
(available only at your station)

FUNCTION

○ + (4) (1) + (Y) . . . (Y) + (#/▲) (Confirmation tone)

#### Notes

- The station to which a call is to be transferred via multi interface unit cannot be programmed as a transfer destination station.
- The programmed contents by dialing operation are automatically saved into the exchange or IP stations at midnight every day. If the exchange or IP station is turned off before completion of save, the state returns to the contents that were programmed before power-off.

**[Calls to stations set for time-based call forwarding]**

**Step 1.** When the preset transfer time is reached, the station's display shows the station (e.g. number 62) has entered the Time-based Call forwarding mode (AN-8000MS/8500MS only).

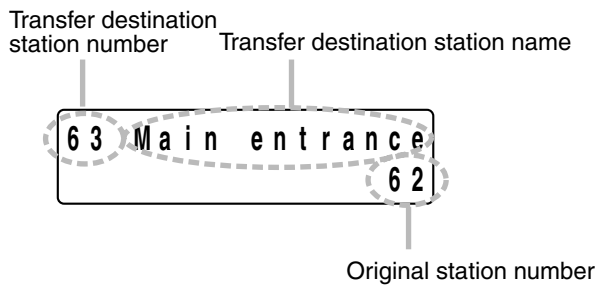

**Step 2.** Calls to stations (original station) are automatically transferred to the transfer destination station without sounding a call tone.

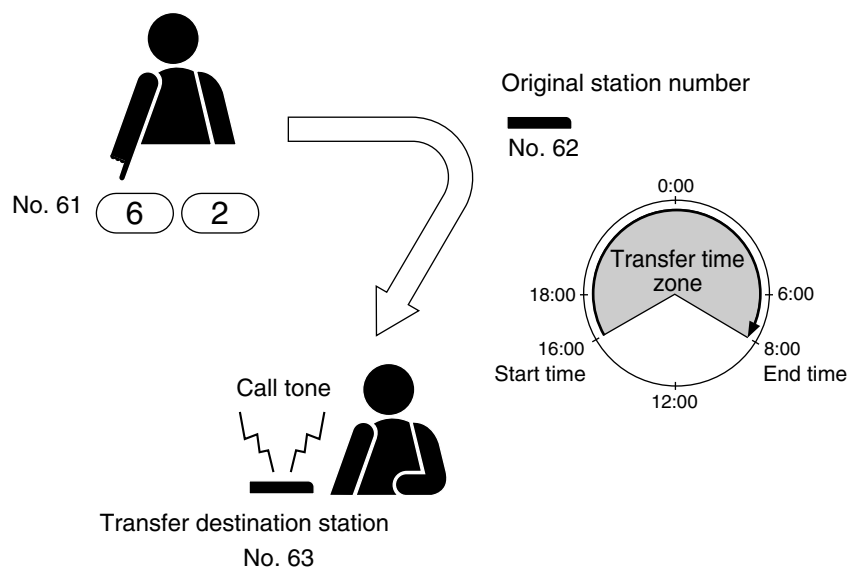

Programming or erasure can be performed at your station.

**[Programming]**      FUNCTION       $\text{○} + \text{4} \text{3} + \text{X} \cdot \cdot \cdot \text{X} + \text{\#/\▲}$  (Confirmation tone)

Function designated number
Transfer destination station number

**[Erasure]**      FUNCTION       $\text{○} + \text{4} \text{3} + \text{Y} \cdot \cdot \cdot \text{Y} + \text{\#/\▲}$  (Confirmation tone)

The originally called (your) station number

**Notes**

- The station to which a call is to be transferred via multi interface unit cannot be programmed as a transfer destination station.
- The programmed contents by dialing operation are automatically saved into the exchange or IP stations at midnight every day. If the exchange or IP station is turned off before completion of save, the state returns to the contents that were programmed before power-off.

## 2.8. Remote Response

Calls to a station can be answered, provided both stations are assigned to the same group.

Up to 16 stations can be set to a Response group.

The Remote Response function can only be used while calls are being made by a continuous call tone.

The Remote response function cannot be used for answering a group call made by the group call function.

(Only the representative station and all member stations in the same group can answer this call.)

### Note

Remote Response group can be set either by dialing operation (see next page) or using the supplied AN-8000 Software program. (Refer to [p. 5-60](#).)

### [Operation example]

While a station (Example: No. 62) is being called by a continuous call tone, the Push-to-talk key of the station (No. 60) belonging to the same group is pressed.

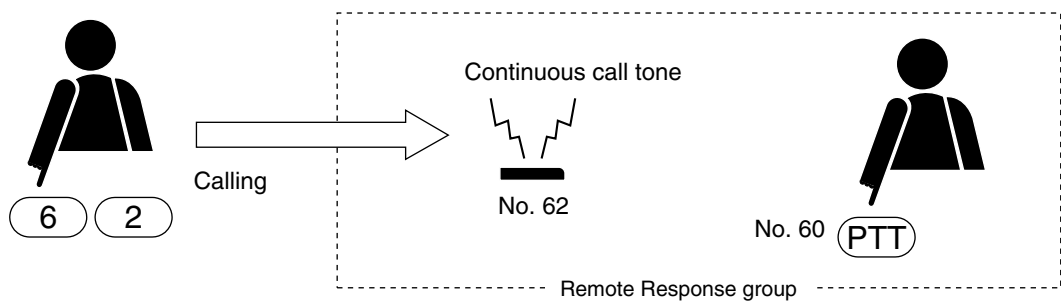

The party (Station No. 60) who presses its station Push-to-talk key can respond instead of the called station (No. 62).

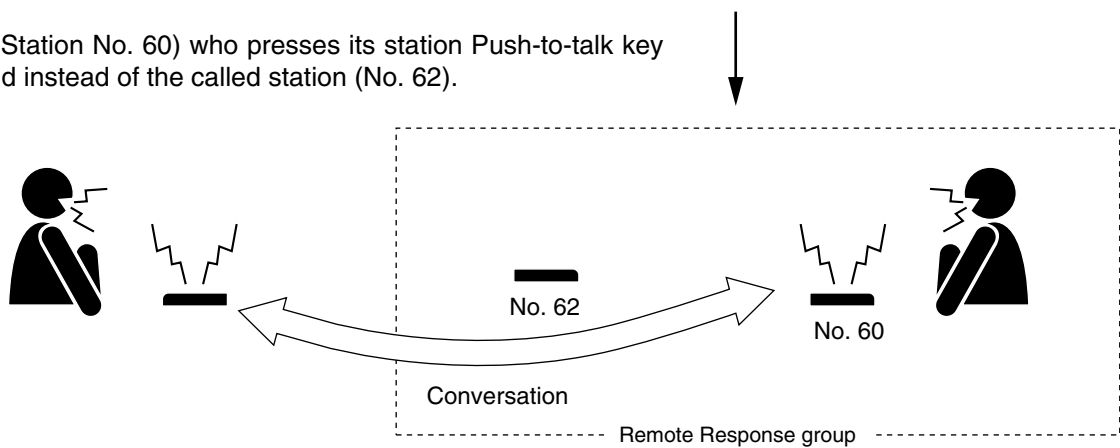



**[Remote response group new programming]**

Function designation number

FUNCTION

○ + (7) (0) + (#/▲) (Confirmation tone)

**[Remote response group member addition]**

Member station number

FUNCTION

○ + (7) (1) + (X) . . . (X) + (#/▲) (Confirmation tone)

**[Remote response group erasure]**

FUNCTION

○ + (7) (2) + (#/▲) (Confirmation tone)

**[Remote response group member erasure]**

Member station number

FUNCTION

○ + (7) (2) + (X) . . . (X) + (#/▲) (Confirmation tone)

**Notes**

- Stations currently set for other Remote Response groups can not establish a different Remote Response group.
- Stations currently set for other Remote Response groups cannot join a different Remote Response group as a member station.
- Stations currently set for other Remote Response groups cannot erase from a member station of the Remote Response group.
- The programmed contents by dialing operation are automatically saved into the exchange or IP stations at midnight every day. If the exchange or IP station is turned off before completion of save, the state returns to the contents that were programmed before power-off.

## 2.9. Executive Priority

If a called station is busy, as indicated by a busy tone, performing Priority operation from a call station transmits a short priority call tone, then forcibly terminates the current conversation, allowing the call to go through. Access to priority call operation or refusal of priority calls can be set individually for each station. Use the supplied AN-8000 Software program to perform the setting. (Refer to p. 5-48, 5-52.)

### [Operation]

When Station A calls Station B, which is at that time engaged in a conversation with Station C, Station A presses its [9] key.

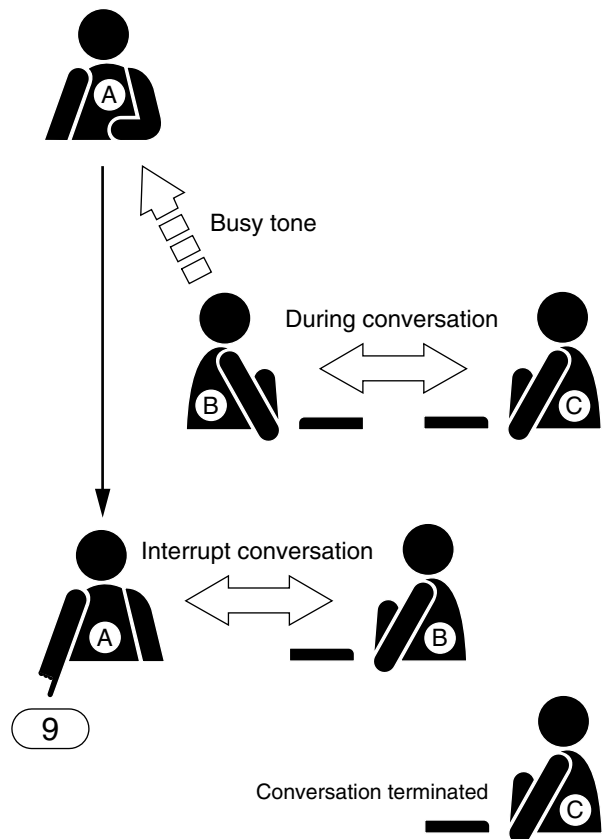

A call tone is transmitted to both Stations B and C, and the conversation is forcibly terminated, enabling Station A to be connected to Station B.

- If a setting has been performed to allow Station B to refuse interrupt calls, the Priority Call function cannot be used, and the busy status remains unchanged.

## 2.10. Time-Out

This function restricts the duration of calling, conversation, and paging to prevent the speech path from being left unused when a user neglects to terminate conversation or paging.

When the set time has elapsed, stations automatically return to standby state.

### Note

Use the supplied AN-8000 software to set each time limit (programmable for 10 – 990 seconds in 10-second units). (Refer to p. 5-29, 5-46.)

### Tip

The time limit is programmed at the exchange to which the station that makes the call is connected, or at the IP station that makes the call.

## 2.11. Group Blocking

Stations can be blocked into groups (up to 31 groups) which can or cannot make calls to each other. Paging zone numbers available among such groups can also be set.

### Note

Use the supplied AN-8000 software to set the station groups, calls that can be made among groups, and paging zones that can be mutually called. (Refer to p. 5-58.)

#### [Group blocking group setting example]

Set arbitrary station groups (up to 31 groups).

Group 1 No. 201 – 209		
Group 2 No. 210 – 219	Group 3 Nos. 220 – 249	Group 4 No. 250 – 279

#### [Setting example for enabling or disabling calls among groups]

Calls that station groups can or cannot make to each other can be freely set. In this example, Group 1 can call Groups 2 – 4 and Group 2 can call only Group 1. Groups 3 and 4 cannot call other groups.

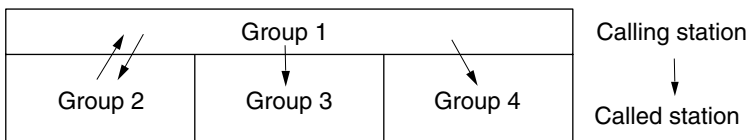

#### [Setting example for paging zone numbers that can be called]

Paging zone numbers that can be called from each group can be freely set. In this example, Group 1 can make all-zone calls or page Zones 1 – 4, Group 2 can make all-zone calls or page only Zone 1, and Group 4 can page only Zone 4.

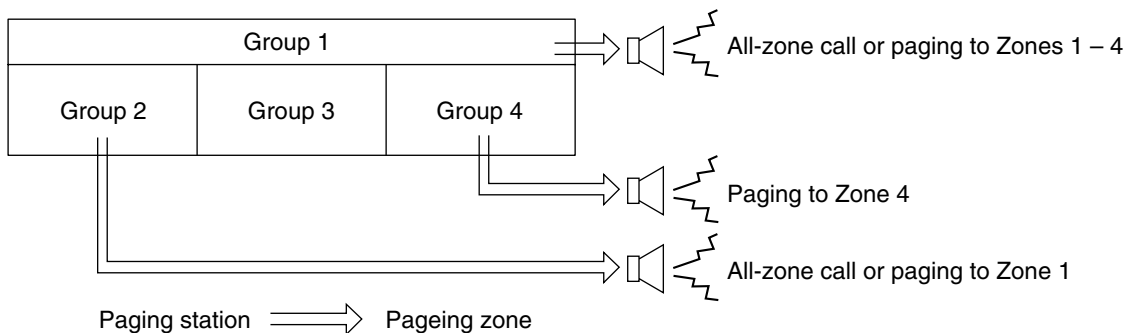

### Note

Paging zones can be set freely regardless of group blocking group assignment.

## 3. PAGING FUNCTION AND OPERATION

### 3.1. Paging

Paging stations are preprogrammed.

Paging durations can be limited by preprogramming the time limit (between 10 and 999 seconds in 10-second units) for each exchange or IP station.

#### Note

Use the supplied AN-8000 Software program to enable or disable the paging operation and to set the paging duration. (Refer to [p. 5-29](#), [5-46](#), [5-48](#), [5-52](#).)

#### 3.1.1. Zone paging

Paging calls can be made to one of the pre-programmed zones.

Use the supplied AN-8000 Software program to set the paging zones. (Refer to [p. 5-57](#).)

**Step 1.** Press the Paging key, followed by the desired paging zone number (1 – 160).

A paging tone is transmitted to the selected zone.

#### Note

Enter a zone number with the same digit length (1 – 3 digits) set by way of the AN-8000 Software program.

**Step 2.** Page with the handset either lifted or in place.

- If the system's paging response mode has been set to designate the zone number (Refer to [p. 2-28](#)), announce the response zone number to the paged party in the paging message.

**Step 3.** Either press the Clear key or replace the handset.

The paging is completed.

#### [Example paging to the zone 23]

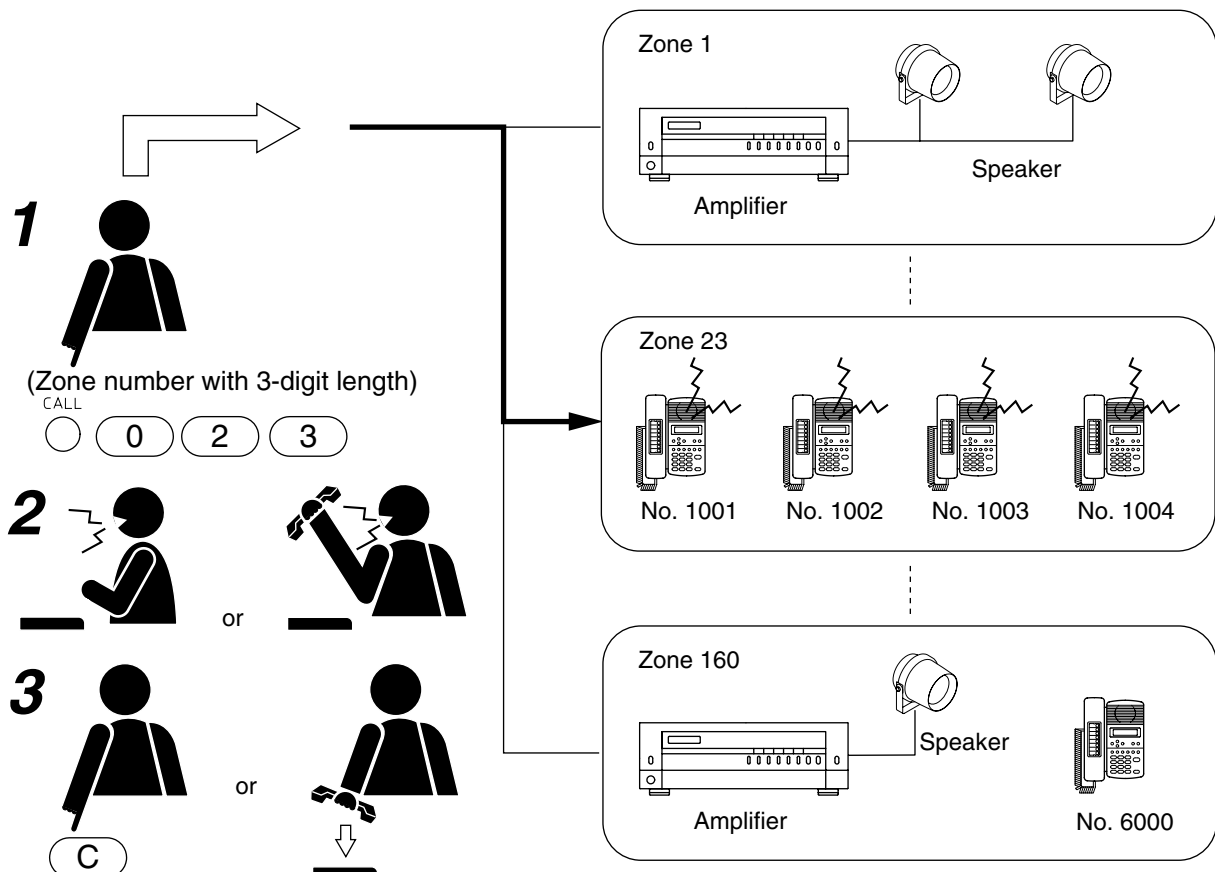

### 3.1.2. Selectable paging

Paging calls can be made to up to 10 zones.

Use the supplied AN-8000 Software program to set the paging zones. (Refer to [p. 5-57.](#))

**Step 1.** Press the Paging key, then [\*/▼] key followed by the desired paging zone number (1 – 160).

**Note**

Enter a zone number with the same digit length (1 – 3 digits) set with the AN-8000 Software program.

**Step 2.** To select the zone numbers consecutively, press the [\*/▼] key.

**Step 3.** To terminate the zone selection, press the [#/▲] key following the zone number.

A paging tone is sounded in the selected zone(s).

**Step 4.** Page with the handset either lifted or in place.

**Note**

If the system's paging response mode has been set to designate the zone number (Refer to [p. 2-28.](#)), notify the paged party of the response zone number (any one of the paged zones) in the paging message.

**Step 5.** Either press the Clear key or replace the handset.

The paging is completed.

[Example paging to the zone 1, 23 and 105.]

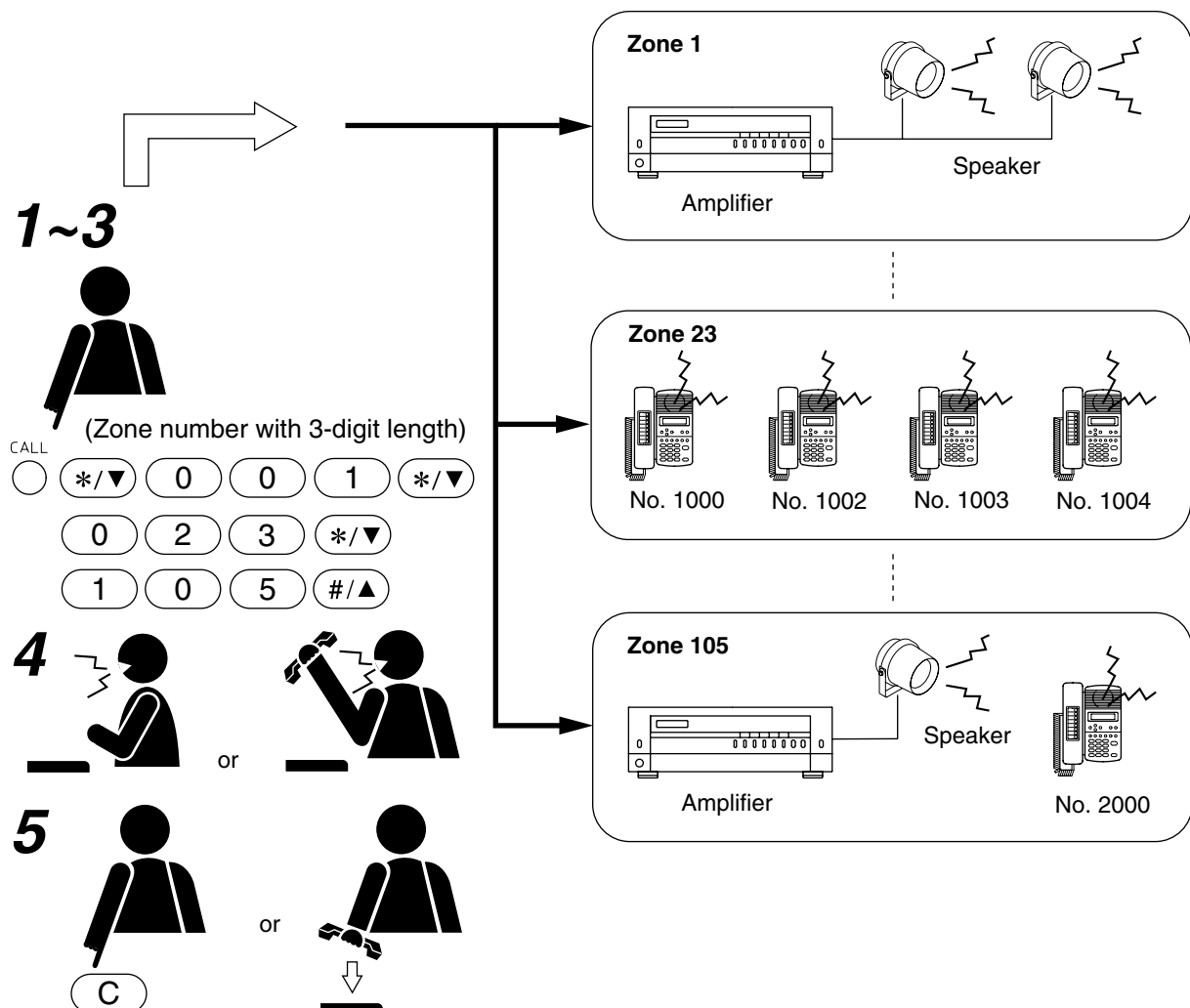

### 3.1.3. All-call paging

Paging calls can be made simultaneously to all of the pre-programmed zones. Use the supplied AN-8000 Software program to set the paging zones. (Refer to [p. 5-57.](#))

**Step 1.** Press the Paging key, followed by the paging zone number 0 (for all-call paging). A paging tone is transmitted to all zones.

**Note**

Enter a zone number with the same digit length (1 – 3 digits) set with the AN-8000 Software program.

**Step 2.** Page with the handset either lifted or in place.

**Note**

If the system's paging response mode has been set to designate the zone number (Refer to [p. 2-28](#)), notify the paged party to respond to [0] in the paging message.

**Step 3.** Either press the Clear key or replace the handset to terminate the page. The paging is completed.

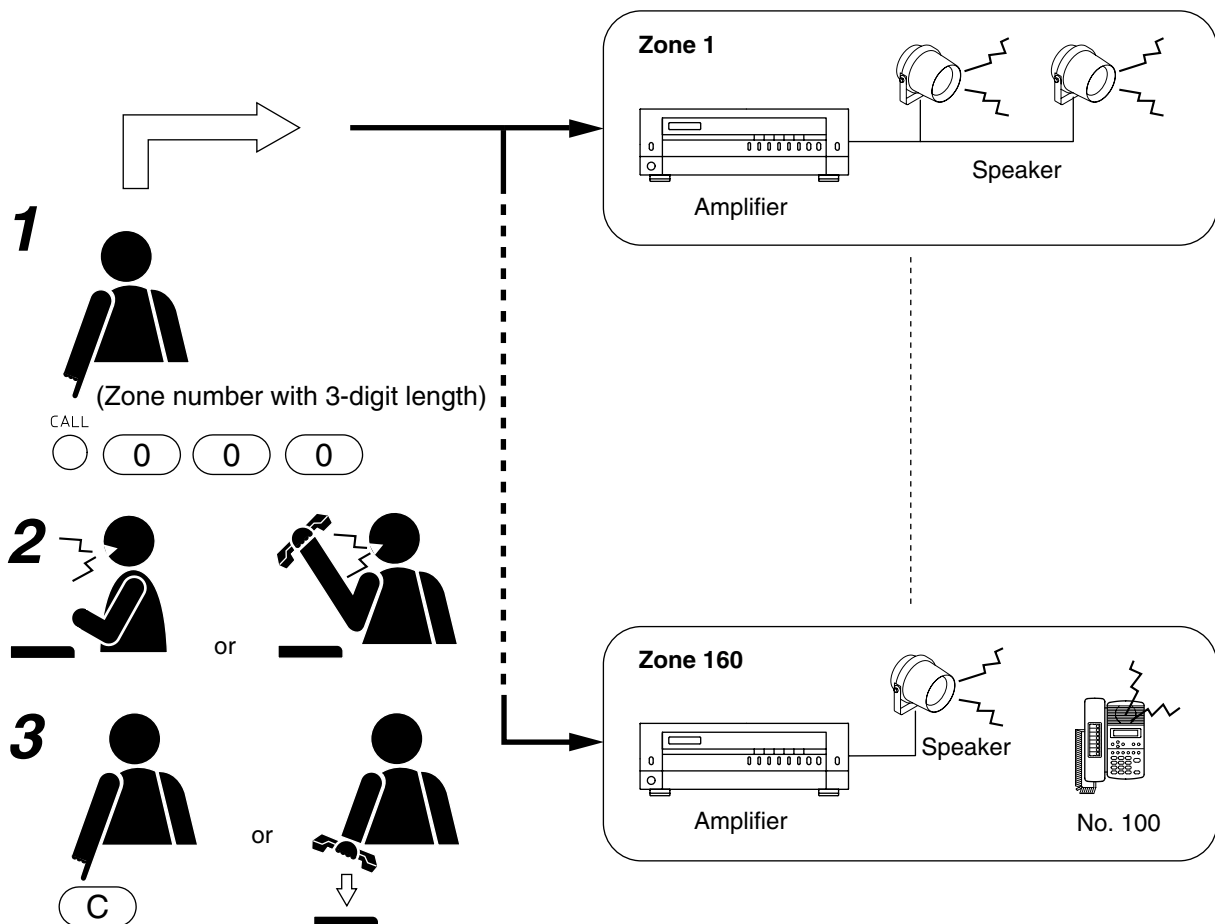

### 3.1.4. Paging priority

The all-call paging has the highest priority, while the zone paging and selectable paging are the same in priority level.

- Initiating the all-call paging during the zone or selectable paging terminates the zone or selectable paging, allowing the all-call paging to go through.
- Initiating another paging of the same priority during a paging causes the later paging to be held busy when the paged station or in-use PA paging output overlap.

### 3.2. External Input Paging (only when the AN-8000MI is used)

Activating the control input after connecting the Remote microphone or playback components to the Multi interface unit enables broadcasting to the preprogrammed zone(s).

There are two methods of activation: one is to use the Audio input terminal (A in the following figure), and the other is to use the Contact input terminal (B).

Set only the broadcast zones when activating the Audio input terminal, and both the broadcast zones and input sound source when activating the Contact input terminal. Set the input sound source operation mode to "External input paging."

#### Note

Use the supplied AN-8000 software to perform each setting. (Refer to p. 5-38, 5-40.)

- Closing the control input terminal broadcasts the outputs from the external sound source to the preprogrammed paging zone(s).
- The broadcast ends when the control input terminal opens.

#### [Example of activating both the audio Input terminal and contact input terminal]

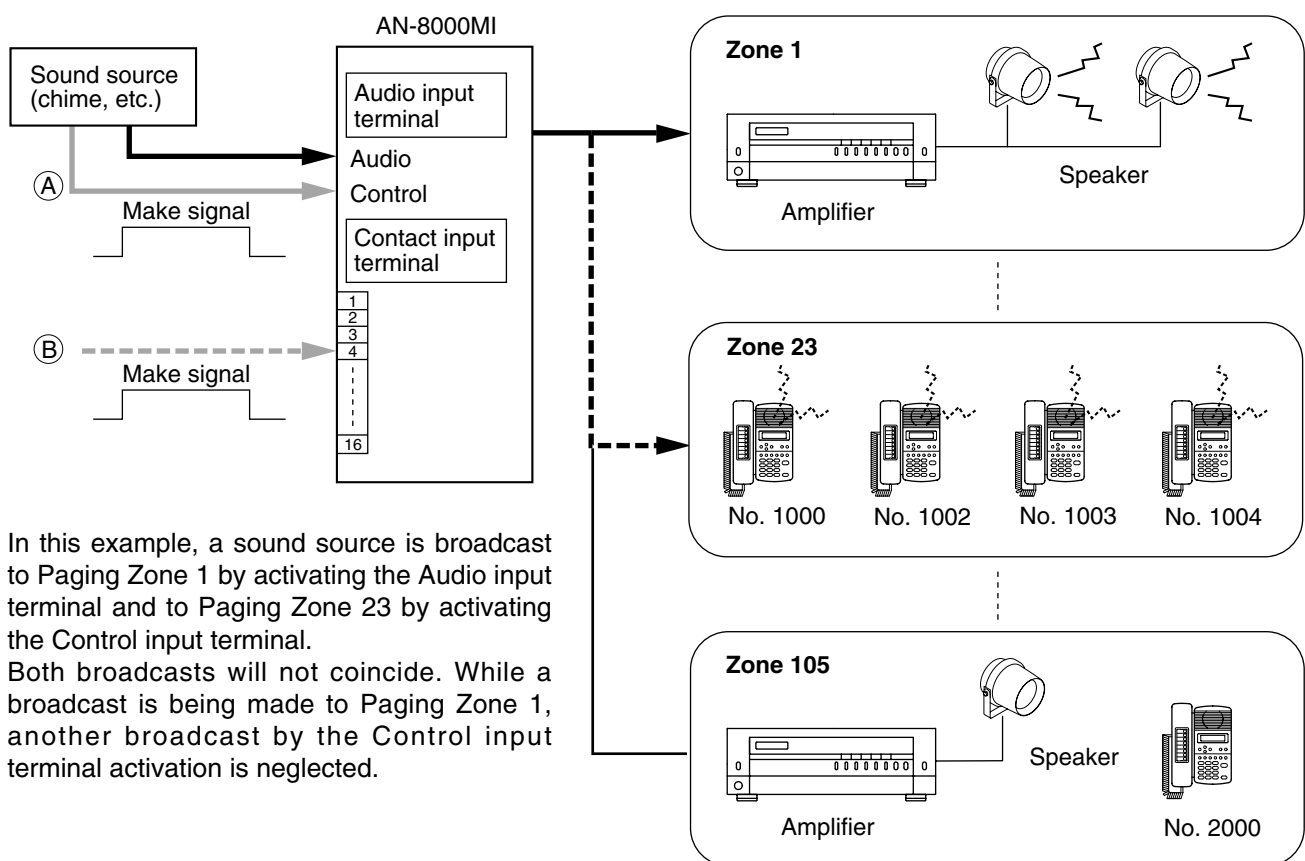

In this example, a sound source is broadcast to Paging Zone 1 by activating the Audio input terminal and to Paging Zone 23 by activating the Control input terminal.

Both broadcasts will not coincide. While a broadcast is being made to Paging Zone 1, another broadcast by the Control input terminal activation is neglected.

#### [Priority]

- There is no priority between control signals coming to the Audio input terminal and the Contact input terminal. Even if either terminal is closed while the other terminal is closed, the later activation is not accepted.
- Priorities are equal between paging calls, whether they are initiated by the AN-8000 system station or other system station. If one input terminal closes while the other terminal is closed for paging, the last paging is placed in standby mode, and is allowed to go through when the other paging is completed.

### 3.3. Responding to Paging

If the paged party responds at the nearest station, the paging party is called and put through to the paged party. "Automatic Response" and "Zone Number Designation Response" modes are available, and the system is preset to one of the two paging response modes. (Refer to p. 5-29, 5-46.)

#### Note

The station that receives station paging operates in either Conversation priority mode or Paging priority mode, which has been already set to the station.

When in Paging priority mode, the station being paged cannot respond to the paging. Respond to the paging after the paging call ends.

#### 3.3.1. Automatic response

If the paged party responds dialing the Paging Response key, the paging party who made the last page is called and put through to the paged party.

#### [Operation]

If the paged party presses the Paging Response key, the paging party who made the last page is called and put through to the paged party.

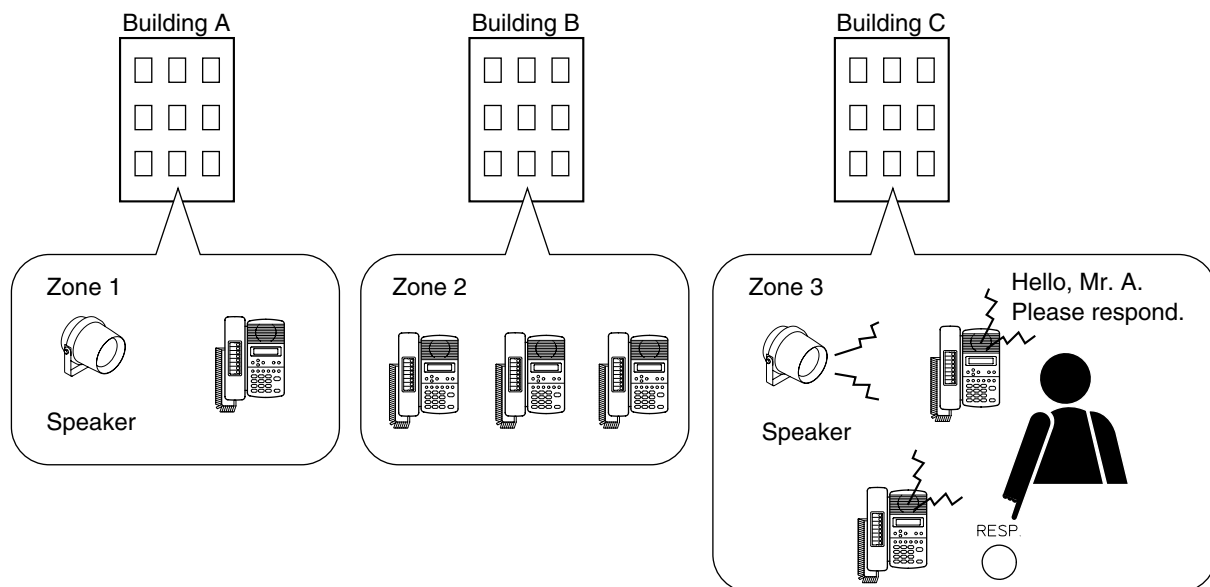

- Since each paging zone is independent, responding from any station where a paging is audible connects the paged party to the paging party.



### 3.3.2. Zone number designation response

If the paged party responds dialing the designated zone number, the paging party who made the paging to the designated zone last is called and put through to the paged party.

When making a paging, the paging party should announce the paging zone to use, and the paged party can dial the designated zone number when responding.

#### [Operations]

Press the Paging Response key, followed by zone number paged.

#### Note

Enter a zone number with the same digit length (1 – 3 digits) set with the AN-8000 Software program.

The paging party who made the paging to the designated zone last is called and put through to the paged party.

#### [Example]

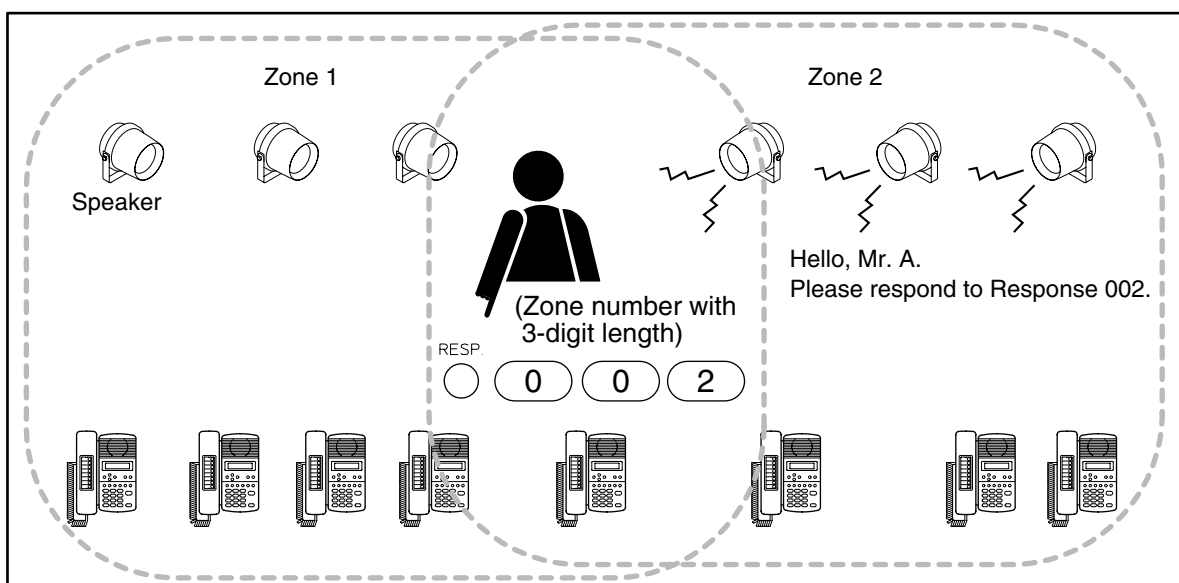

The station that can make response is as follows.

- Station assigned to the paged zone
- Station connected to the same exchange as the station assigned to the paged zone or the PA paging output are connected to.

## 4. OTHER FUNCTIONS AND OPERATION

### 4.1. Scan Monitor

The station can scan an arbitrary group of pre-programmed stations for auditory monitoring.

Stations are monitored in preprogrammed sequence at specified time intervals.

Manual control from the monitoring station can also be performed.

Up to 16 stations can be programmed to the same monitor group.

Up to 4 station groups (up to 64 stations) can be monitored in sequence from a single station.

- Use the supplied AN-8000 Software program to set a monitor group or scan monitor duration. (Refer to p. 5-51, 5-56.)
- Stations not in standby mode are skipped and not monitored.
- The status indicator on the monitored station remains in standby mode and unchanged.

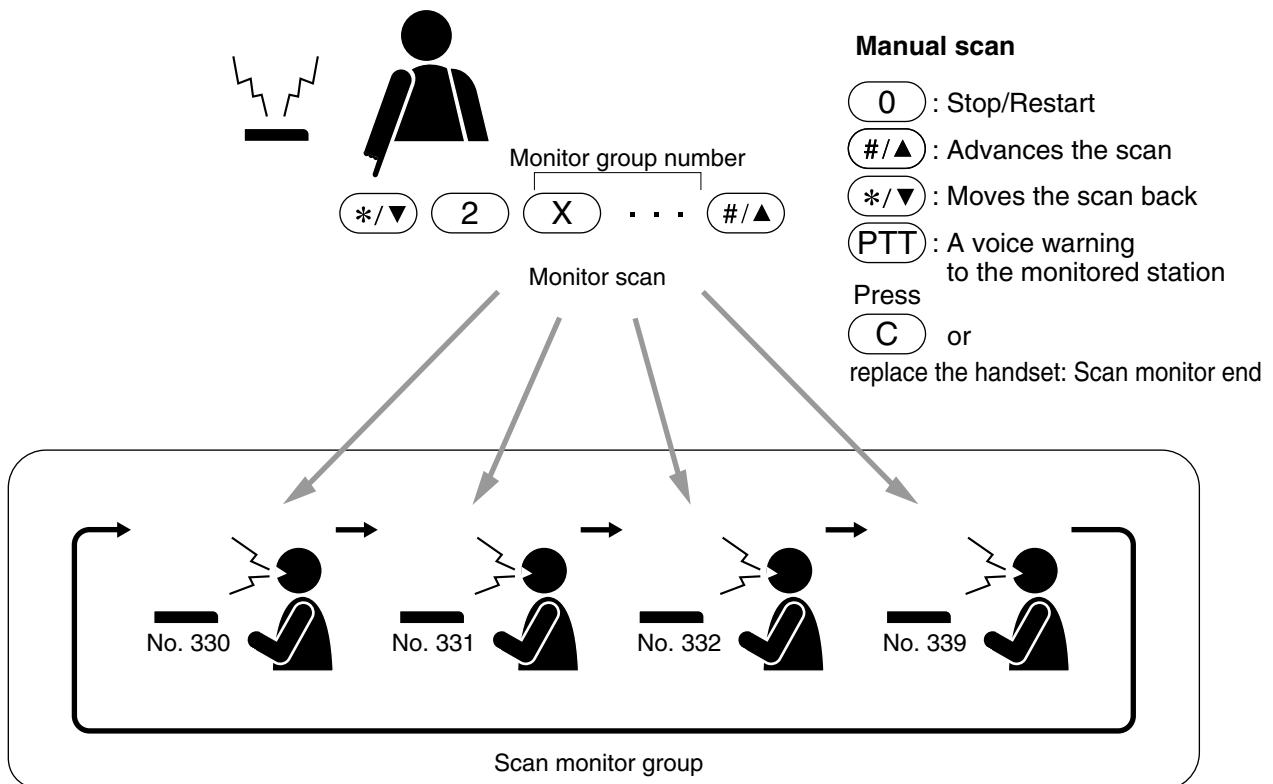

#### [Operation]

##### Step 1. Automatic Scan

Press the [\*/▼] and [2] keys, and after dialing the monitor group number (1 – 4), press the [#/▲] key.

When monitoring two or more groups, dial the group numbers consecutively.

- Scan monitoring is started and cycles through the station groups in preprogrammed sequence and at specified time intervals until its operation is manually stopped.
- Both the number and name of the station being monitored are displayed on the monitoring station's liquid crystal display. (AN-8000MS/8500MS only)

**[Example] Station No. 331 is being monitored.**



- A handset can also be used for monitoring.

**Step 2. Manual Scan****2-1. Stopping and restarting automatic scan**

To continuously monitor a specified station, press the [0] key when that station is displayed to stop automatic scan operation. Pressing the [0] key again restores automatic scan operation.

**2-2. Advancing a scan**

Pressing the [# / ▲] key advances the scan by one station.

**2-3. Moving back a scan**

Pressing the [\* / ▼] key moves the scan back one station.

**2-4. Warning the monitored station by voice**

To transmit a voice warning to the monitored station, press the Push-to-talk key.

**Step 3. Scan Monitor end**

To end Scan monitor, either press the Clear key or replace the handset.

**4.2. PBX Connection (only when the AN-8000MI is used)**

If the Multi interface unit is connected to the PBX's analog E&M interface, calls or conversations can be mutually made between the AN-8000 system's stations and the PBX's extension telephones or paging calls can be initiated from the PBX extension telephone.

**4.2.1. Calling the PBX extension telephone****Step 1. Dial the analog E&M interface access number at a AN-8000 system's station.**

The station is connected to a PBX.

**Step 2. Confirm that a dial tone from the PBX is heard, then dial the PBX extension number.**

The extension telephone is called.

**Note**

Set the analog E&M interface access number using the supplied AN-8000 software. (Refer to [p. 5-38.](#))

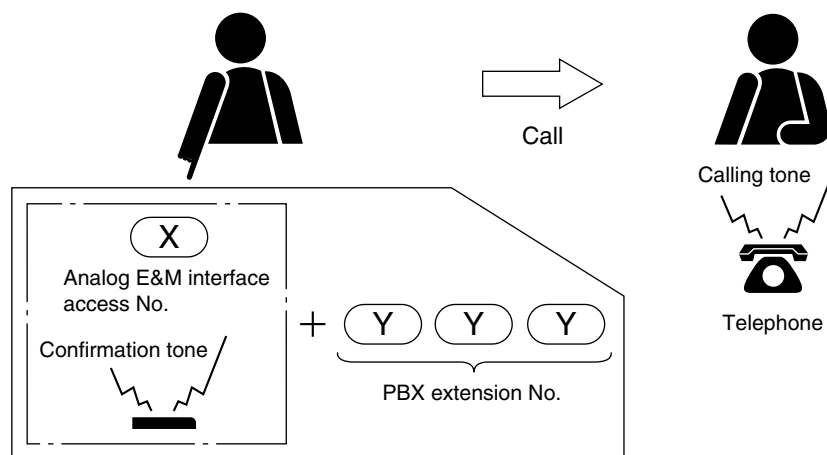

### 4.2.2. Being called from a PBX extension telephone

Dialing the intercom access number as well as the AN-8000 system's station number at the PBX extension telephone permits the AN-8000 system's station to be called.

The method for receiving a call from the PBX extension telephone at the AN-8000 system's station is the same as when it is called by another station within the system.

#### Note

Set the intercom access number at the PBX.

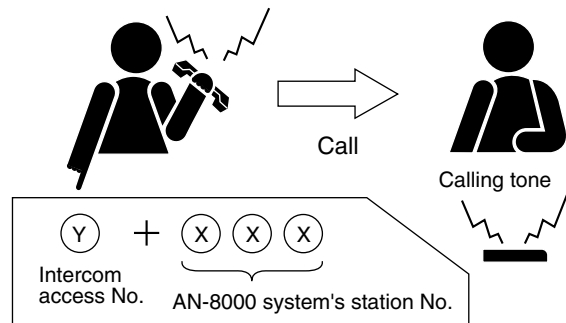

### 4.2.3. Being paged from a PBX extension telephone

Dialing the intercom access number, "\*" , "8," and the AN-8000 system's paging operation number in this order at the PBX extension telephone permits the paging calls to be made to the AN-8000 system's stations.

The method for responding a paging call at the station is the same as when it is paged from the AN-8000 system's station. (Note that paging response is valid only while the paging call is in progress.)

#### Notes

- Paging calls from the PBX extension telephone can be made only when line attribute is set to "PB" using the supplied AN-8000 software. (Refer to [p. 5-38](#).)
- Set the intercom access number at the PBX.

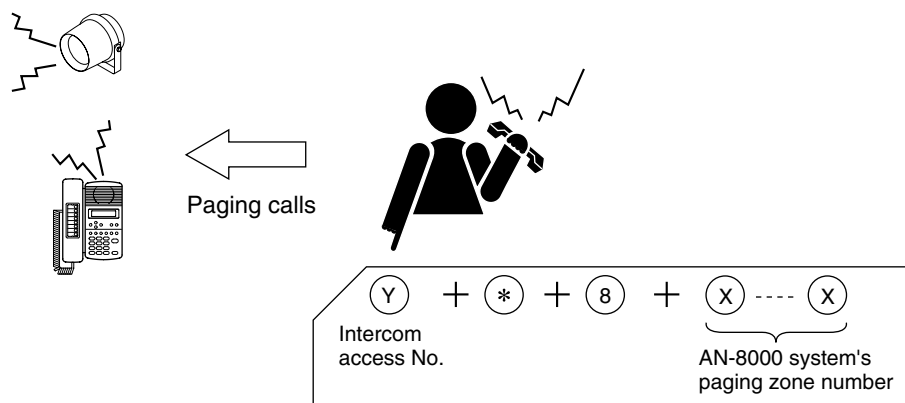

### 4.3. BGM (only when the AN-8000MI is used)

Connecting playback components to the Multi interface unit permits Background music selectable from up to 8 programs to be heard from each station speaker while in standby mode.

It is possible to make or receive calls at the station even in BGM mode. In this event, BGM broadcasts are automatically interrupted.

Interrupted BGM broadcasts are automatically restored after the conversation or paging is completed.

#### Notes

- Use the supplied AN-8000 software to set the unit number and audio input number of the Multi interface unit with connected playback components, and the stations that can receive BGM broadcasts. (Refer to p. 5-29, 5-38, 5-46, 5-48, 5-52.)
- Since BGM is lower than conversations and paging in priority, BGM may be interrupted at a BGM-broadcast station even if the station performs no operation when other station makes a call or paging with all speech links busy.
- For a Multi interface unit connected to playback components and exchanges connected to stations that select BGM, perform settings so that they can be connected to the network that enables multicast communications (Refer to p. 5-23) of high-quality mode (Refer to p. 5-24, 5-31, 5-42).

#### [Channel Selection]

- Press [Function key][1][Channel number].

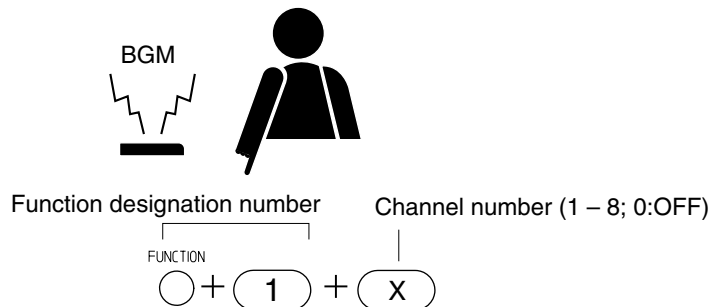

- Pressing [Function key][1][ #/▲ ] increases the channel number by 1 (1 → 2 → ...7 → 8 → 0...).

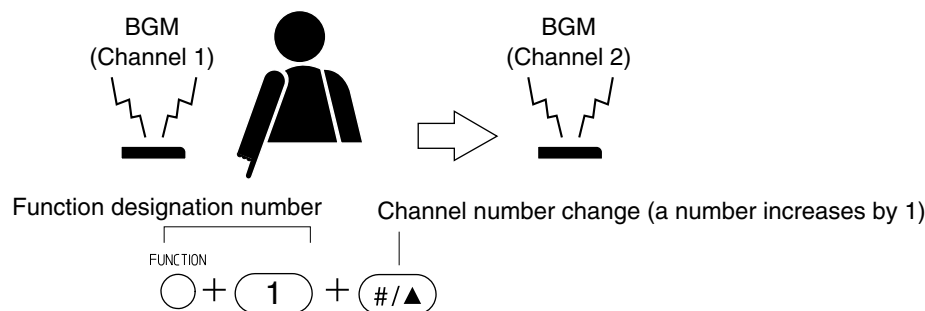

- Pressing [Function key][1][ \*/▼ ] decreases the channel number by 1 (1 → 0 → 8 → 7...).

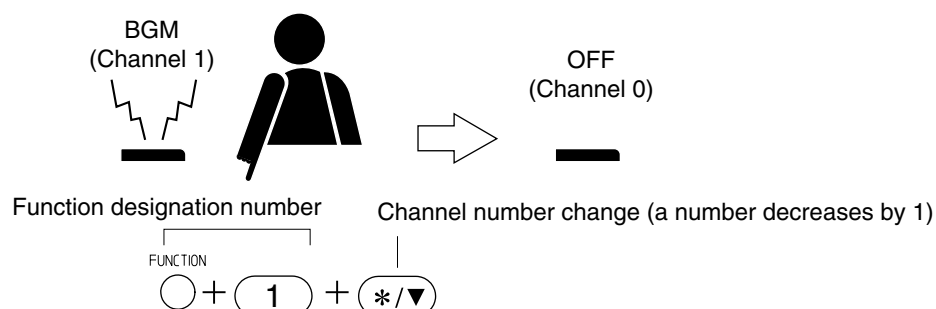

**[BGM volume adjustment]**

BGM volume can be adjusted in 5 increments.

- Press [Function key][1][9][ #/▲ ] to increase the volume.

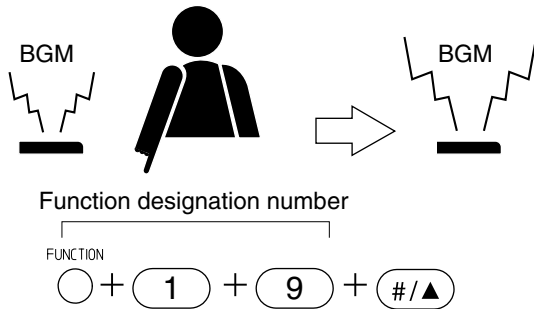

- Press [Function key][1][9][ \*/▼ ] to decrease the volume.

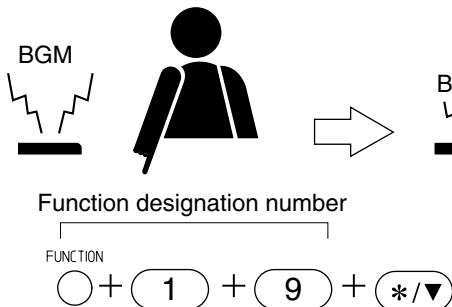
**4.4. External Equipment Control (only when the AN-8000MI is used)**

By transmitting a one-shot make signal or make/break signal to the designated contact of the Multi interface unit through operation of the station, external equipment can be controlled. Remote door lock control can be performed using the one-shot make output, and indication boards can be controlled using the make/break output.

**Note**

Use the supplied AN-8000 software to set the one-shot make duration, operation number digits, operation numbers, and the stations allowed to control external equipment. (Refer to [p. 5-36](#), [5-40](#), [5-48](#), [5-52](#).)

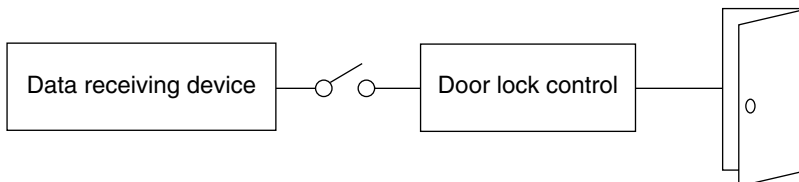
**[Door remote control example using one-shot make output control]****[Hospital waiting status indication board example using the make/break output]**

1	6	11	16
2	7	12	17
3	8	13	18
4	9	14	19
5	10	15	20

**[One-shot make output operation]**

Press [Function key][3][0] and then the access number for the contact corresponding to the external equipment to be controlled.

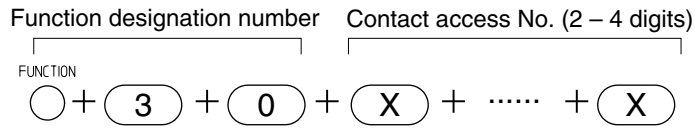
**[Make output operation]**

Press [Function key][3][1] and then the access number for the contact corresponding to the external equipment to be controlled.

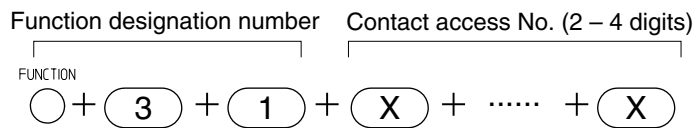
**[Break output operation]**

Press [Function key][3][2] and then the access number for the contact corresponding to the external equipment to be controlled.

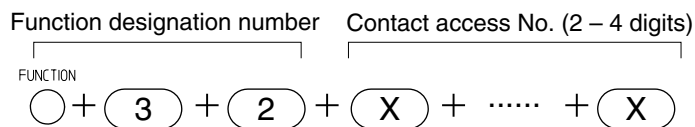

### 4.5. Calling Station Indication/CCTV Interlock (only when the AN-8000MI is used)

By installing a lamp type indication board\* at the specified station, conversation partners and calling stations that made calls to the specified station during conversation can be displayed on the board. The indication board can be shared among multiple stations (up to 8 stations) to indicate which station within the group has been called. It is also possible to use the AN-8000MI's contact for interlocking the AN-8000MI with a CCTV system so that a calling party is displayed on the monitor screen.

\* Needs to be separately made to interlock with the multi interface unit's output.

**Note**

Use the supplied AN-8000 software to set the Multi interface unit's contact number and the stations equipped with the indication board. (Refer to p. 5-29, 5-46, 5-48, 5-52.)

**[Calling station indication example]**

- When a station equipped with the indication board is called, the lamp for the calling station lights. The lamp extinguishes when a response is made to the call and the conversation is terminated.

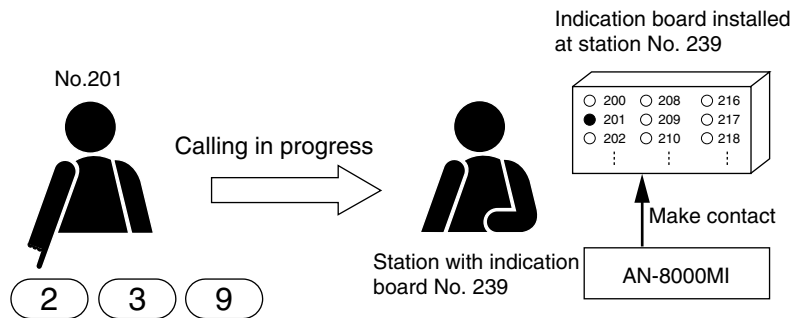

- Even if the station equipped with the indication board is on another line when it is called, the lamp for the calling station (i.e. station in camp-on-busy mode) lights.

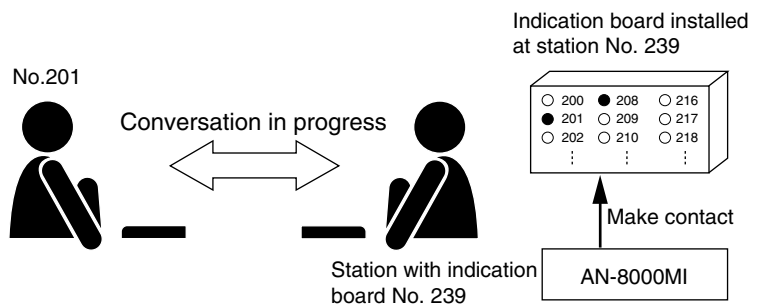

- The lamp extinguishes when the station in camp-on-busy mode stops waiting.

**Note**

Operations in this description are based on the calling station indication mode being set to "Call activated." Perform the setting using the supplied AN-8000 software. (Refer to p. 5-29, 5-46.)

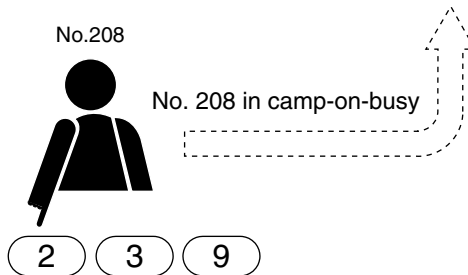

**[CCTV interlock example]**

- When there is a call to the station with a CCTV monitor, responding to the call displays the calling station's image on the monitor.

**Note**

Operations in this description are based on the calling station indication mode being set to "Response activated." Perform the setting using the supplied AN-8000 software. (Refer to p. 5-29, 5-46.)

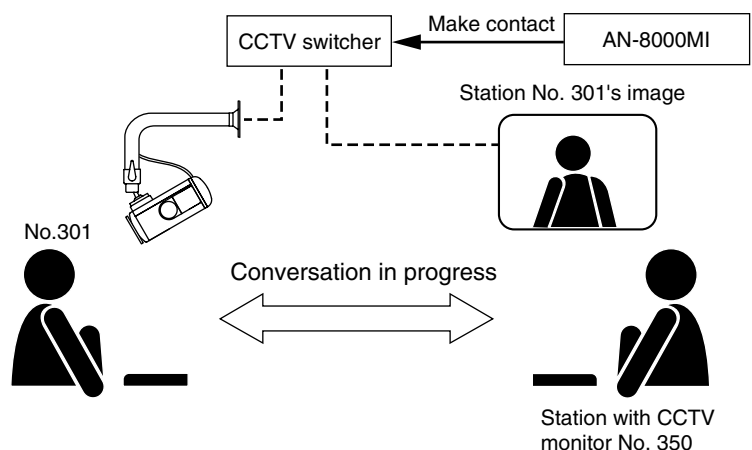



#### 4.6. Door Remote Control (only when the AN-8050DS/8540DS/N-8000MI is used)

AN-8050DS/8540DS's contact outputs can be shorted for a set period of time by the dial operation at the master station engaged in conversation with the AN-8050DS Door Station or AN-8540DS IP Door Station. Similarly, the Multi interface unit's contact outputs can be shorted for a set period of time by the dial operation at the master station engaged in conversation with a station.

For example, a door lock can be controlled by connecting the contact outputs to an electronic lock system. Use the supplied AN-8000 Software to perform settings for the one shot make duration and the AN-8000MI's contact output corresponding to each station. (Refer to p. 5-29, 5-36, 5-46, 5-48, 5-52.)

##### [Operation]

**Step 1.** Press the Transfer key during a conversation.

Current conversation is placed on hold, transmitting a hold tone to other party.

**Step 2.** Press the Function key and [0] key.

Contact outputs of AN-8050DS/8540DS in conversation or the station's corresponding AN-8000MI's contact outputs can be shorted for a set period of time.

For example, the corresponding door lock can be released if contact outputs are connected to an electronic lock system.

**Step 3.** A confirmation tone sounds, and the original conversation is restored.

##### [Example of AN-8050DS/8540DS operation]

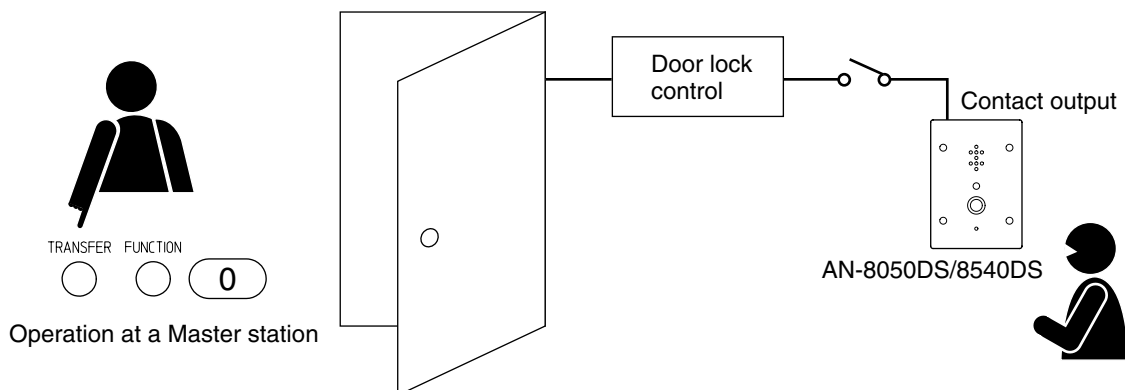

##### [Example of AN-8000MI operation]

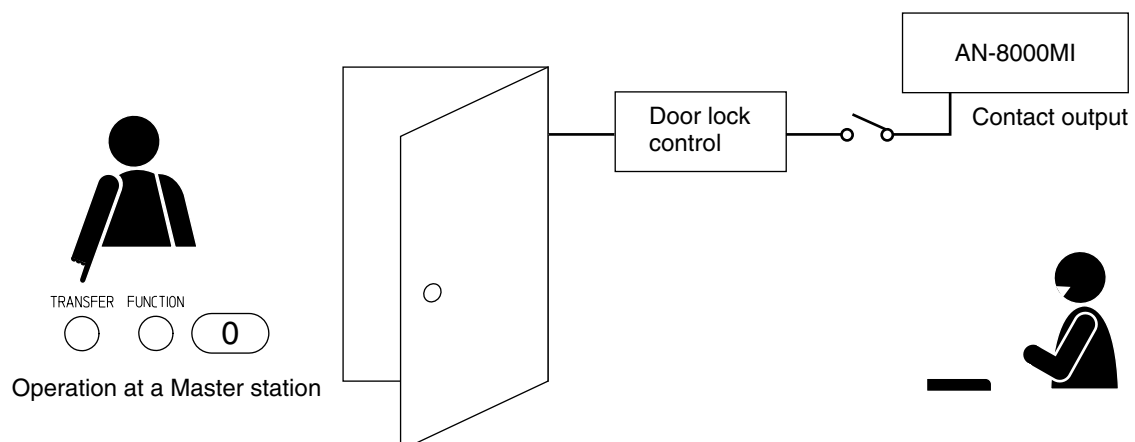

#### 4.7. Contact Bridge (only when the AN-8000MI is used)

Contact signals can be transmitted by way of a network.

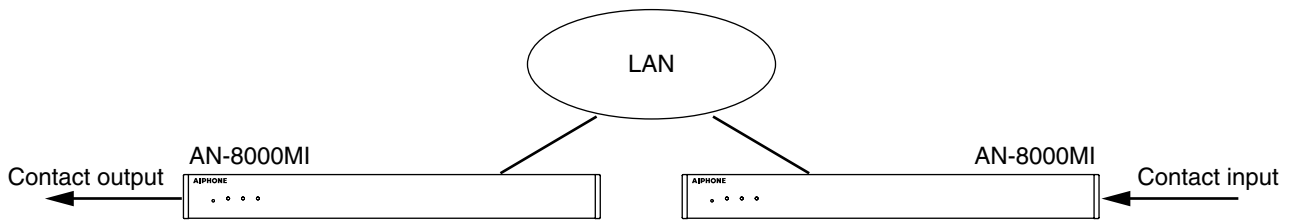

Either of the following 2 control input's operation modes can be selected to perform this function.

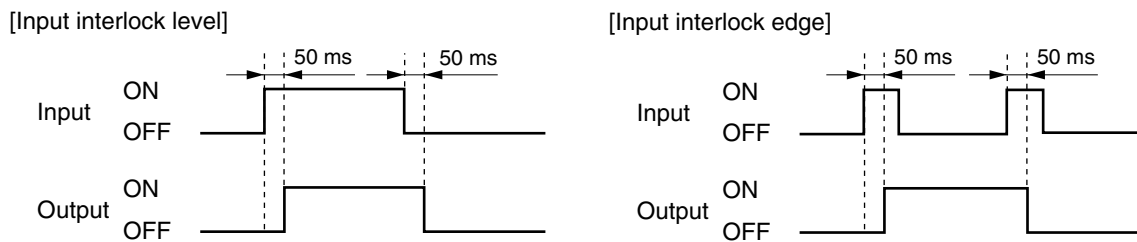

#### Notes

- The input is defined when its level remains constant for 50 ms after change.
- Use the supplied AN-8000 software to make settings for the contact bridge function. (Refer to [p. 5-40](#).)

#### 4.8. Paging Busy Input (only when the AN-8000MI is used)

Busy status data from an airport broadcast system or similar large sound systems can be received when the AN-8000MI is interlocked with such systems, allowing important information to be accurately transmitted.

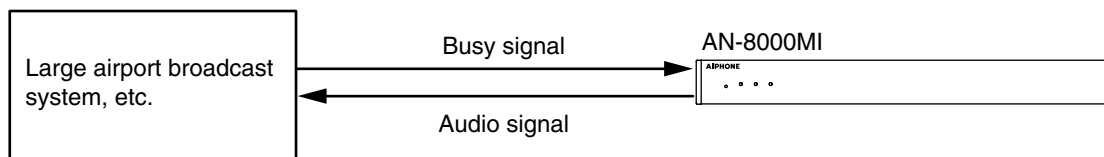

#### Note

Use the supplied AN-8000 software to set the contacts to be used for paging busy input. (Refer to [p. 5-40](#).)

## 5. MASTER STATION OPERATION TABLE

Function	Item	Operation	Remarks	
Call/Response	Call	Dial station No. XXXX	Station No: 2 – 6 digits	
	Redialing	Press the [Redial] key		
	Recall	Press the [# / ▲] key		
	Voice Calling	Voice a call to a called party by pressing the [PTT] key as the continuous call tone sounds.		
	Response	Press any key or lift the handset.		
Conversation	Handset conversation	Conversation can be made by lifting the handset.		
	Hands-free conversation	Conversation can be made without lifting the handset.		
	PTT conversation	Press the [PTT] key during a hands-free conversation.		
Speed dialing	Auto-dialing	Press the Auto-dialing key ( [1] – [8].)	AN-8000MS/8500MS only	
	One-touch dialing	Press [7] , [8] , [9] , [0] or lift the handset.		
Hold	Mic Off	Continuously hold down any key ([0] – [9]) during a conversation.		
	Call hold	Press the [Hold] key during a conversation.		
	Call hold release	Press the [Hold] key during hold.		
Call transfer	Call transfer	Press the [Transfer] key during a conversation. → The other party is placed on hold. Dial the third party's station number. → Conversation with the third party. (Original conversation party is placed on hold). Either press the [C] key or replace the handset. → Call transfer completion		
	Returning to the original conversation	Press the [Transfer] key during a conversation. → The other party is placed on hold. Dial the third party's station number. → Conversation with the third party. (The original conversation party is placed on hold). Press the [Transfer] key again. → Return to the original conversation. (The original conversation is restored).		
Automatic call transfer	Call forwarding	Programming at your station	Dial [Function] [4] [1] [the designated station No.] [# / ▲] keys.	Station No: 2 – 6 digits
		Erasure at your station	Dial [Function] [4] [1] [your station No.] [# / ▲] keys.	
		Programming at the designated station	Dial [Function] [4] [2] [your station No.][# / ▲] keys.	
	Time-based call forwarding	Programming	Dial [Function] [4] [3] [the designated station No.] [# / ▲] keys.	
		Erasure	Dial [Function] [4] [3] [your station No.] [# / ▲] keys.	
	Absence transfer	Programming	Dial [Function] [4] [4] [the designated station No.] [# / ▲] keys.	
Erasure		Dial [Function] [4] [4] [your station No.] [# / ▲] keys.		
Group hunting	Programming	Dial [Function] [4] [5] [the designated station No.] [# / ▲] keys.		
	Erasure	Dial [Function] [4] [5] [your station No.] [# / ▲] keys.		
Remote response		When call is received to the station assigned to the same group, press the [PTT] key.		
Executive priority		If a called station is busy, press the [9] key.		
Scan monitor	Start	Dial [* / ▼] [2] [Monitor group No.] [Monitor group No.] . . . [# / ▲] keys.	Dial during monitoring	
	Stop/Restart	Press [0] to stop. Press [0] again to restart.		
	Advancing Scan	Press [# / ▲] key to advance the scan by one station.		
	Reverse Scan	Press [* / ▼] key to move the scan back one station.		
	Voice transmission	Press [PTT] to establish conversation.		
	End	Either press the [C] key or replace the handset.		
Paging	Zone paging	Dial [Paging] [Zone No.] keys.	Zone No.: 1 – 3 digits	
	Selectable paging	Dial [* / ▼] [Zone No.] [* / ▼] [Zone No.] [* / ▼] . . . [Zone No.] [# / ▲] keys.		
	All-call paging	Dial [Paging] [0] keys.		
Paging Response	Automatic Response	Press [Paging Response] key.		
	Zone number dialing	Dial [Paging Response] [Zone No.] keys.	Zone No.: 1 – 3 digits	
Station speaker output settings	Increase volume	Press [# / ▲] key during a conversation.		
	Decrease volume	Press [* / ▼] key during a conversation.		
Ambient Noise Control		Dial [* / ▼] [# / ▲] keys without lifting the handset.		
Door remote		Dial [Transfer] [Function] [0] keys during a conversation.		

Function	Item	Operation	Remarks
BGM	Channel selection	Dial [Function] [1] [channel number] keys.	Channel number: 0 – 8
		Dial [Function] [1] [# / ▲ ] keys.	Increasing a number by 1
		Dial [Function] [1] [* / ▼ ] keys.	Decreasing a number by 1
	Volume up	Dial [Function] [1] [9] [# / ▲ ] keys.	
	Volume down	Dial [Function] [1] [9] [* / ▼ ] keys.	
External equipment control	One-shot make output	Dial [Function] [3] [0] [contact access number] keys.	Contact access number: 2 – 4 digits
	Make output	Dial [Function] [3] [1] [contact access number] keys.	
	Break output	Dial [Function] [3] [2] [contact access number] keys.	

## 6. MULTIFUNCTIONAL MASTER STATION'S LCD DISPLAY TABLE

### • In standby mode

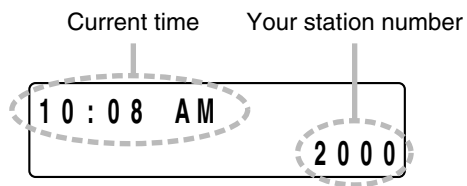

### • During call or conversation mode

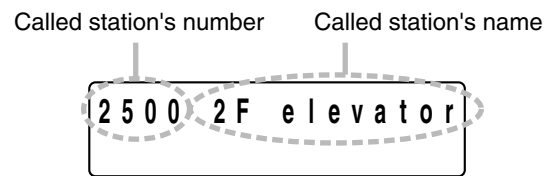

### • Calling or during a conversation in transfer mode

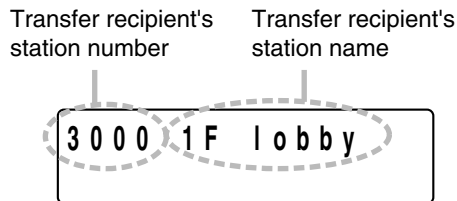

### • During scan monitor mode

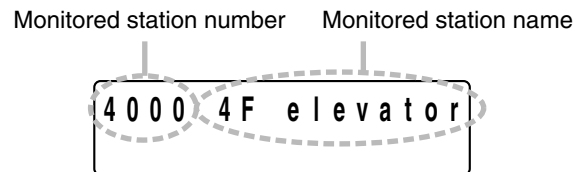

### • Paging call mode

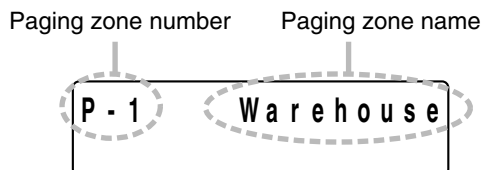

### • Paging receiving mode

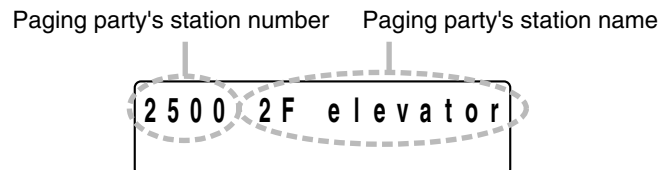

### • Dialing mode

Function registration key operation display example



Dial key:                    0 – 9, \*, #  
Paging key:                PC  
Paging response key:    PR  
Function key:              FN  
Other keys:                No indication

# ***Chapter 3***

---

## ***INSTALLATION & WIRING***

This chapter describes installation and wiring procedures, including the installation and connection of the Exchange, Multi interface unit, and stations.

## 1. INSTALLATION OF THE EXCHANGE

The Exchange can be installed in any of three ways: (1) equipment rack mounting, (2) wall mounting, and (3) desk-top installation.

### 1.1. Equipment Rack Mounting

- A) Elevated Operating Ambient - If installed in a closed or multi-unit rack assembly, the operating ambient temperature of the rack environment may be greater than room ambient. Therefore, consideration should be given to installing the equipment in an environment compatible with the maximum ambient temperature (T<sub>ma</sub>) specified by the manufacturer.
- B) Reduced Air Flow - Installation of the equipment in a rack should be such that the amount of air flow required for safe operation of the equipment is not compromised.
- C) Mechanical Loading - Mounting of the equipment in the rack should be such that a hazardous condition is not achieved due to uneven mechanical loading.
- D) Circuit Overloading - Consideration should be given to the connection of the equipment to the supply circuit and the effect that overloading of the circuits might have on overcurrent protection and supply wiring. Appropriate consideration of equipment nameplate ratings should be used when addressing this concern.
- E) Reliable Earthing - Reliable earthing of rack-mounted equipment should be maintained. Particular attention should be given to supply connections other than direct connections to the branch circuit (e.g. use of power strips)."

The Exchange can be mounted on the CR-273 or CR-413 or standard EIA 19" Equipment rack. One CR-273 for up to 128 stations, one CR-413 for up to 192 stations and seven CR-413 for up to a total of 1280 stations can be connected. (Refer to p. 1-8.) For the CR-273 and CR-413 Equipment rack assembly or BU-412 Blower unit installation, read the installation manual supplied with the rack.

#### Note

When installing the Blower units, Terminal boards, and Exchanges, lay the equipment rack down face-up to do installation work safely. Since the Blower unit is installed from the inside of the rack, be sure to install it first, before mounting the other components.

#### 1.1.1. Setting space

For maintenance works, allow much space between the wall and Equipment rack.

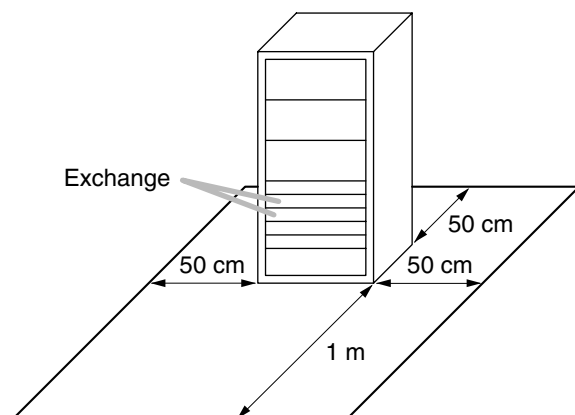

#### 1.1.2. Caution when installing the unit

#### **⚠ CAUTION**

Do not block the fan exhaust vent. Doing so may cause heat to build up inside the unit and result in fire.

Do not stack up 3 Exchanges or more. If 2 or more Exchanges are mounted in the Equipment rack, be sure to mount the perforated panel of 1-unit size (PF-013B) or more above and below every 2 Exchanges.

Using the supplied rack mounting screws, install the terminal board in a location that facilitates wiring and maintenance work, taking into consideration the direction of cable entry into the rack.

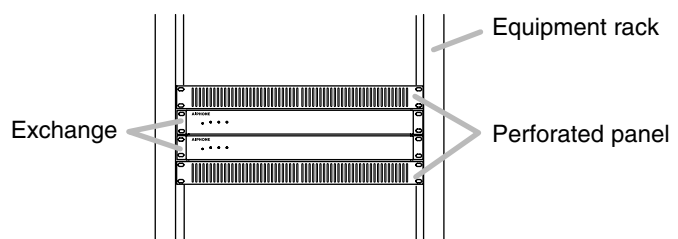

### 1.1.3. Exchange mounting

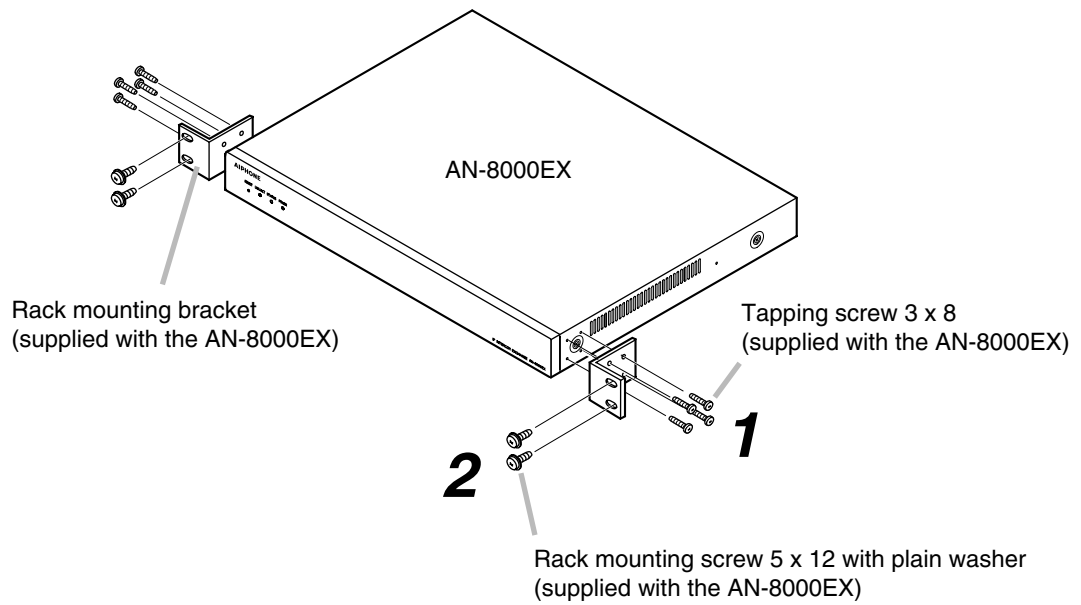

**Step 1.** Install the rack-mounting bracket to the Exchange.

**Step 2.** Mount the Exchange on the Equipment rack.

### 1.2. Desk-Top Installation

When installing the Exchange on a desk, secure the supplied plastic feet to bottom surface of the Exchange using the supplied machine screws.

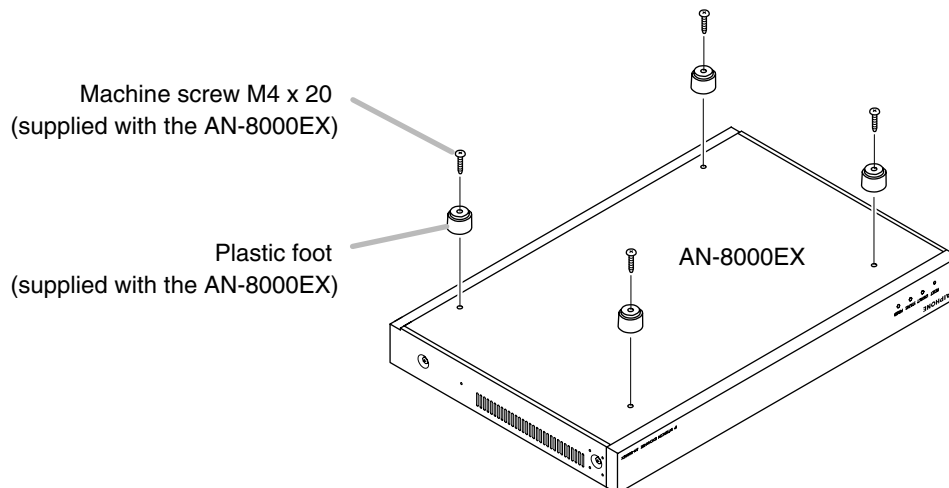

### 1.3. Wall Mounting

**Step 1.** Install the supplied wall-mounting bracket to the Exchange using each 2 supplied screws and removed screws from the case.

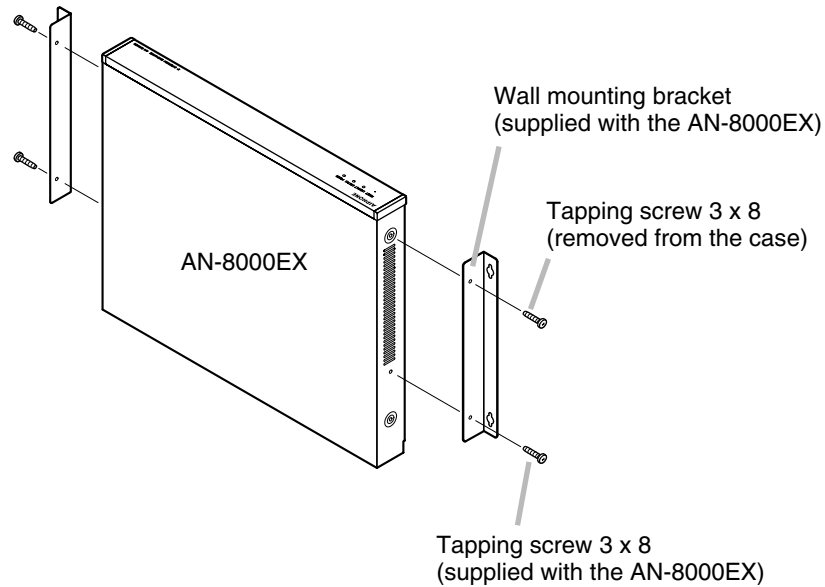

**Step 2.** Mount the Exchange on the wall.

**Notes**

- Use appropriate screws for the construction of wall.
- Wood screws 3.5 x 20 are supplied with the AN-8000EX.
- The socket-outlet shall be installed near the equipment and shall be easily accessible.

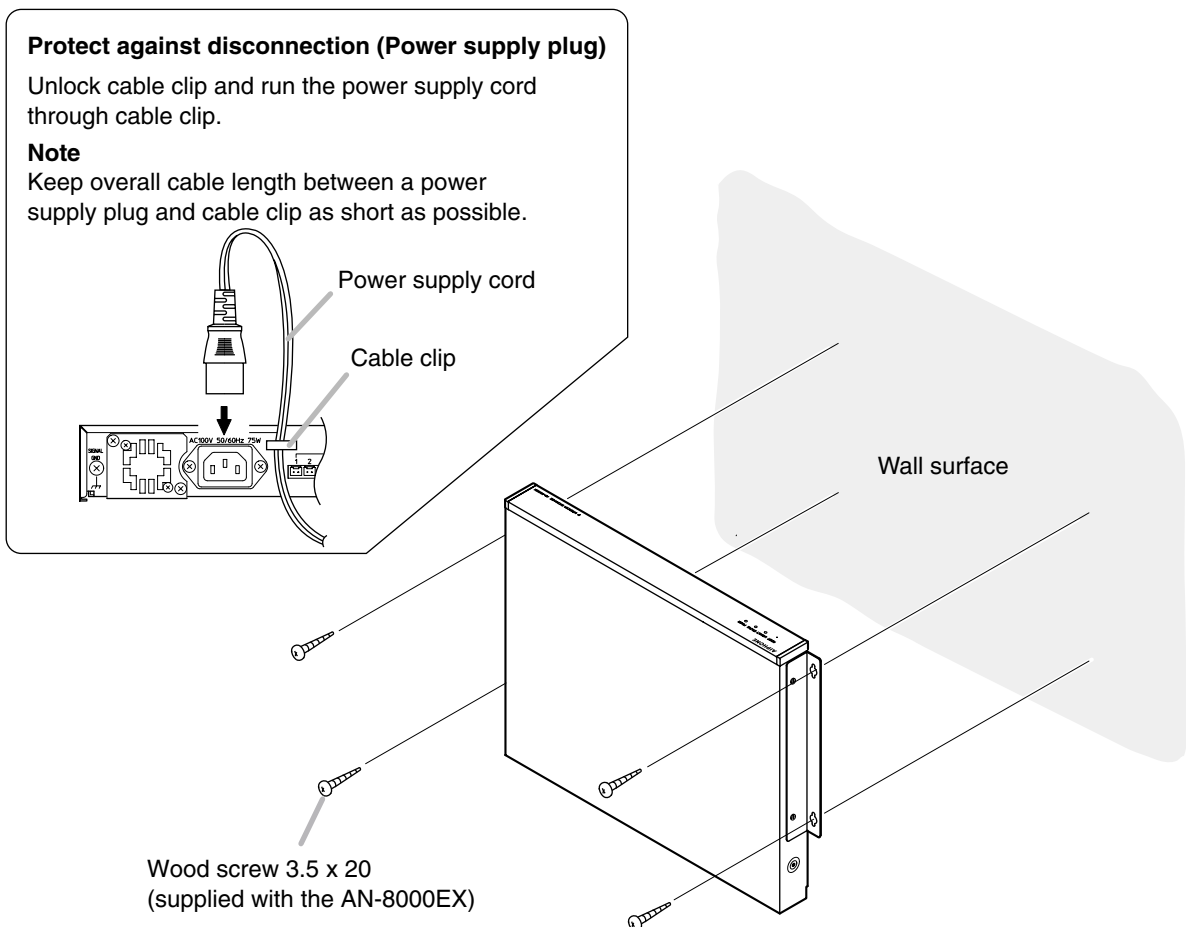



## 2. INSTALLATION OF THE MULTI INTERFACE UNIT

The AN-8000MI can be installed in any of three ways: (1) equipment rack mounting, (2) wall mounting, and (3) desk-top installation.

### 2.1. Equipment Rack Mounting

- A) Elevated Operating Ambient - If installed in a closed or multi-unit rack assembly, the operating ambient temperature of the rack environment may be greater than room ambient. Therefore, consideration should be given to installing the equipment in an environment compatible with the maximum ambient temperature (T<sub>ma</sub>) specified by the manufacturer.
- B) Reduced Air Flow - Installation of the equipment in a rack should be such that the amount of air flow required for safe operation of the equipment is not compromised.
- C) Mechanical Loading - Mounting of the equipment in the rack should be such that a hazardous condition is not achieved due to uneven mechanical loading.
- D) Circuit Overloading - Consideration should be given to the connection of the equipment to the supply circuit and the effect that overloading of the circuits might have on overcurrent protection and supply wiring. Appropriate consideration of equipment nameplate ratings should be used when addressing this concern.
- E) Reliable Earthing - Reliable earthing of rack-mounted equipment should be maintained. Particular attention should be given to supply connections other than direct connections to the branch circuit (e.g. use of power strips)."

The AN-8000MI can be mounted on the CR -273 or CR -413 or standard EIA 19" Equipment rack. For the CR -273 and CR -413 Equipment rack assembly, read the installation manual supplied with the rack.

#### Note

When installing the AN-8000MI, lay the equipment rack down face-up to do installation work safely.

#### 2.1.1. Setting space

For maintenance works, allow much space between the wall and Equipment rack.

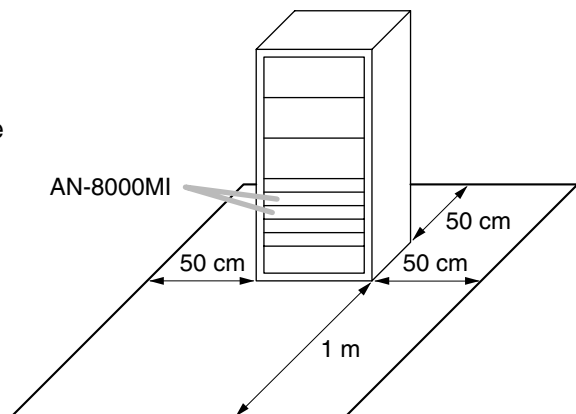

#### 2.1.2. Caution when installing the unit

#### **CAUTION**

Do not block the ventilation slots. Doing so may cause heat to build up inside the unit and result in fire.

Do not stack up 3 units or more. If 2 or more units are mounted in the Equipment rack, be sure to mount the perforated panel of 1 U size (PF-013B) or more above and below every 2 units.

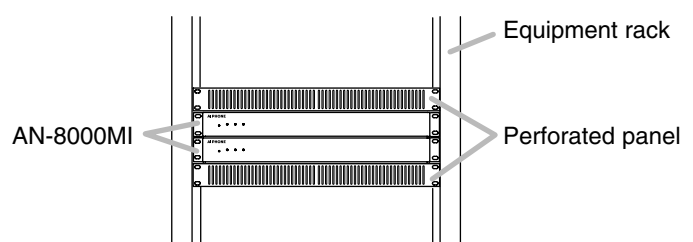

### 2.1.3. AN-8000MI mounting

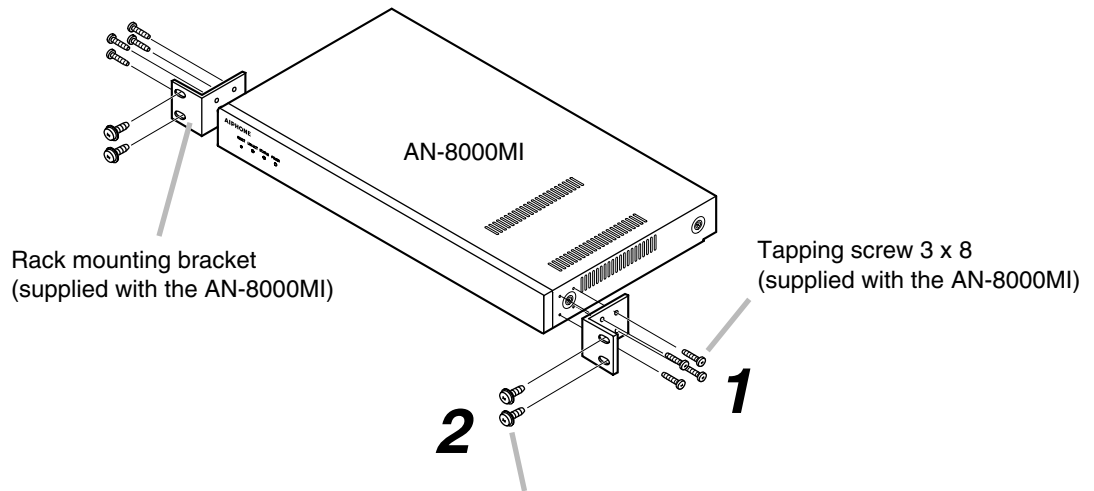

**Step 1.** Install the rack-mounting bracket to the AN-8000MI.

Rack mounting screw 5 x 12 with plain washer (supplied with the AN-8000MI)

**Step 2.** Mount the AN-8000MI on the Equipment rack.

## 2.2. Desk-Top Installation

When installing the AN-8000MI on a desk, secure the supplied plastic feet to the unit's bottom using the supplied machine screws.

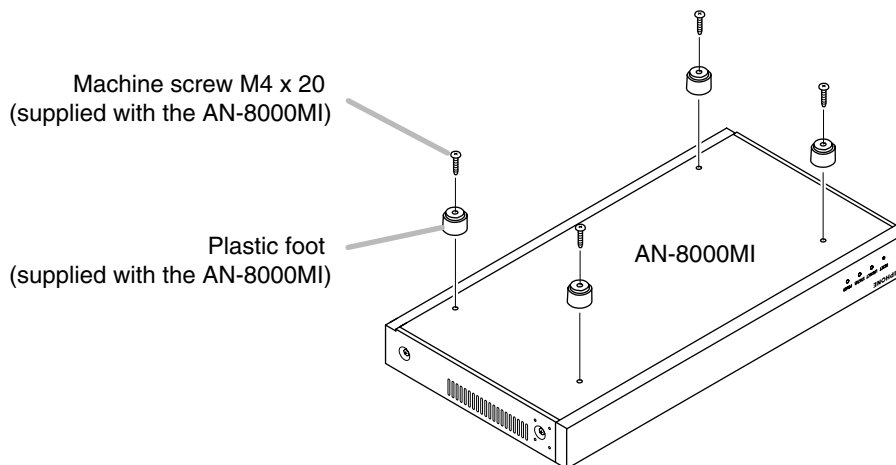

### 2.3. Wall Mounting

**Step 1.** Install the supplied wall-mounting bracket to the AN-8000MI using 4 removed screws from the case.

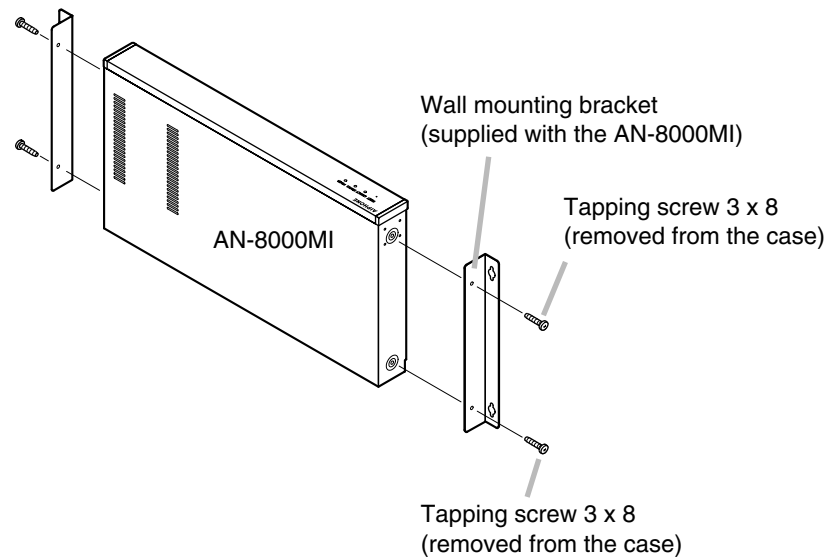

**Step 2.** Mount the AN-8000MI on the wall.

**Notes**

- Use appropriate screws for the construction of wall.
- Wood screws 3.5 x 20 are supplied with the AN-8000MI.
- The socket-outlet shall be installed near the equipment and shall be easily accessible.

**Protect against disconnection (Power supply plug)**

Unlock cord clamp and run the power supply cord through it.

**Note**  
Keep the cable length between a power supply plug and cord clamp as short as possible.

Power supply cord

Cord clamp

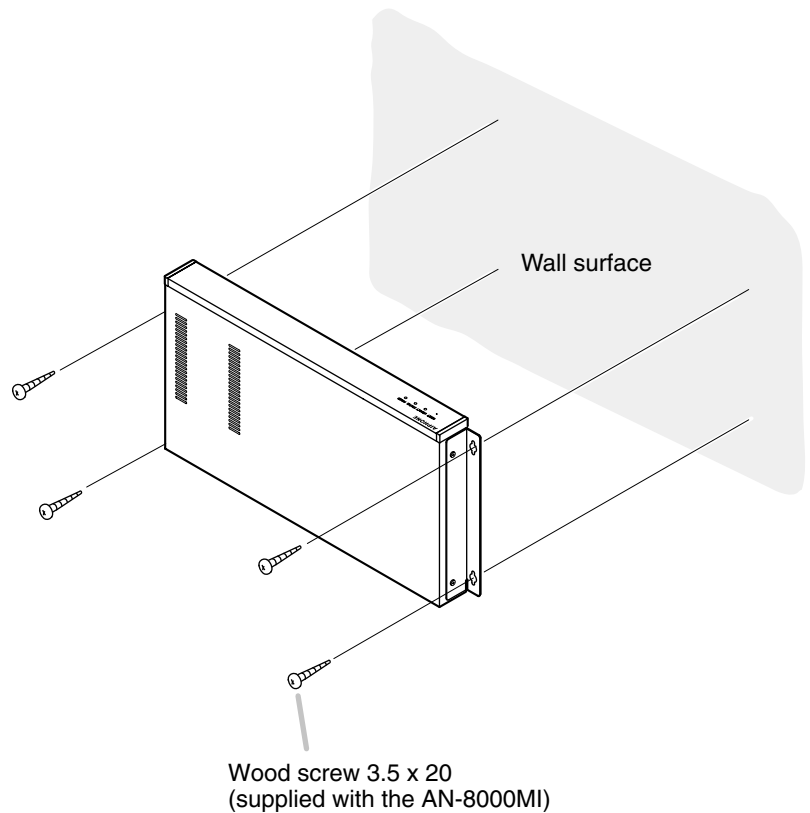

### 3. INSTALLATION OF STATIONS

Stations can be installed in either of two ways: (1) wall mounting or (2) desk-top installation.

#### Note

When using the PA paging function, keep the station as far away from the PA paging speaker as possible to avoid acoustic feedback.

#### 3.1. When Mounting the Station on a Wall

When mounting the station on a wall, the orientation of the handset hook needs to be changed.

##### 3.1.1. AN-8000MS/8010MS/8500MS

**Step 1.** Raise the number directory cover forward tab.

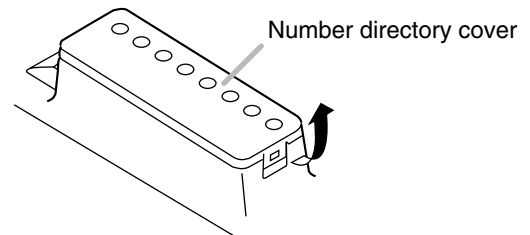

**Step 2.** Remove both the number directory cover and the directory. Remove the handset hook and reverse its orientation, then replace.

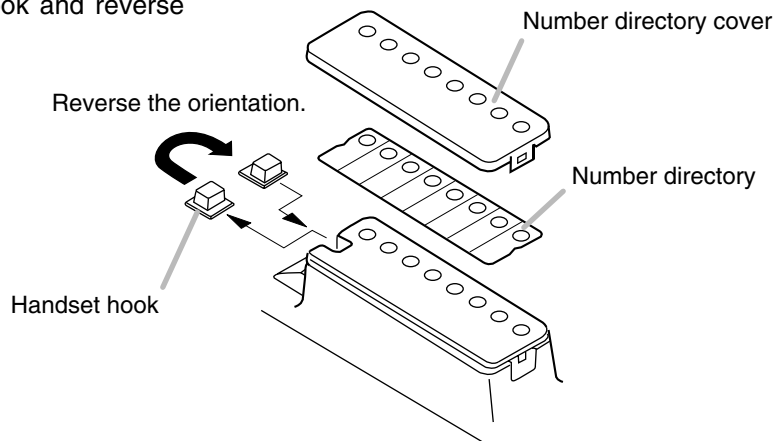

**Step 3.** After replacing the directory on the station, hook the directory cover's forward tab and push on the upper part of the directory cover.

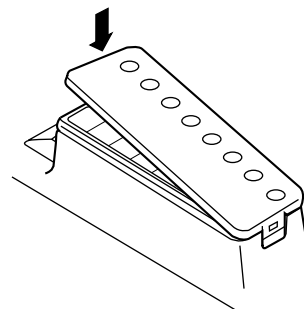

##### 3.1.2. AN-8020MS

Remove the handset hook and reverse its orientation.

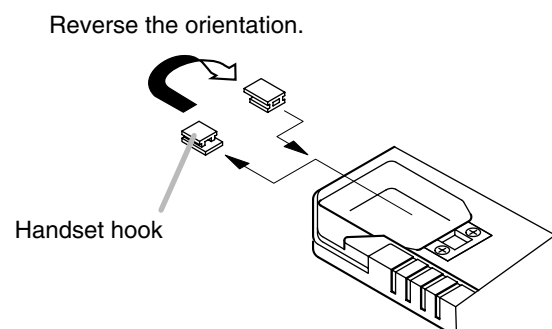

## 3.2. On-Wall Mounting

### 3.2.1. AN-8000MS/8010MS/8020MS/8500MS

The station can be mounted on a wall using an optional YC-280 Wall-mounting bracket. The YC-280 can be installed to a one-gang electrical box.

#### [Mounting example]

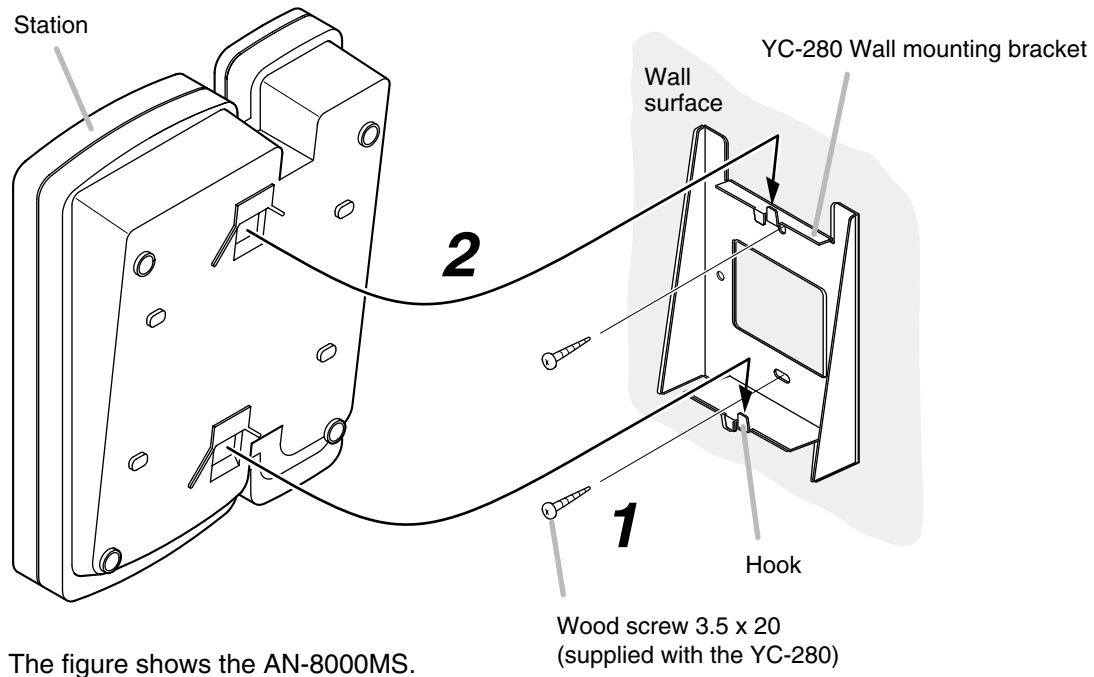

**Step 1.** Install the YC-280 wall mounting bracket to the wall.

#### Notes

- Use the appropriate screws for the construction of wall.
- Wood screws 3.5 x 20 are supplied with the YC-280.
- No fitting screws for electrical box are supplied with. Use commercially available screws.

**Step 2.** Hang the station on the wall mounting bracket hook to install. Push down the station main body in the direction indicated by the arrow.

[YC-280 dimensional drawing]

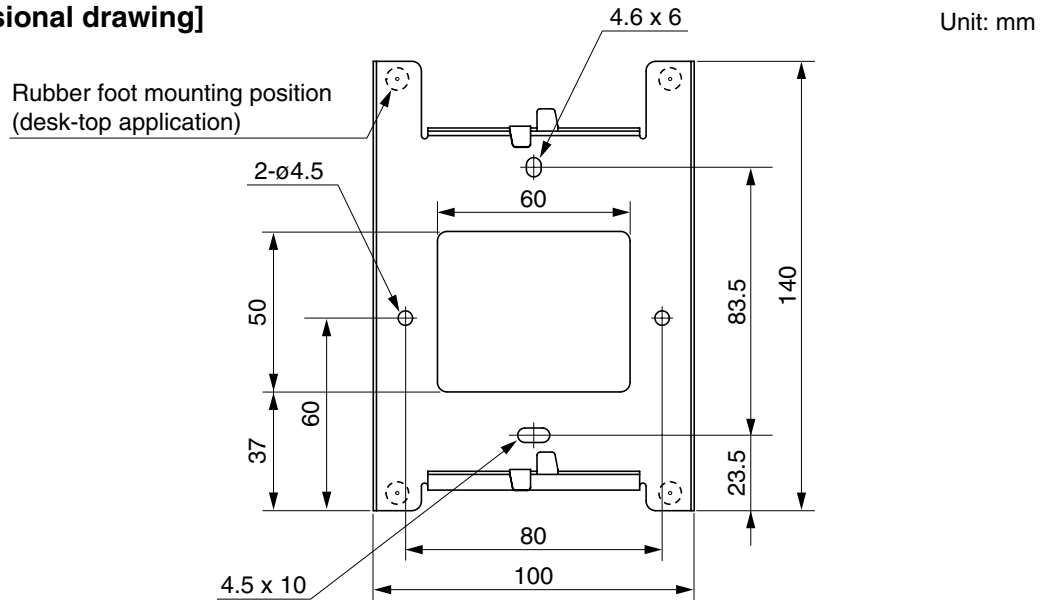

[Installation completion drawing]

- AN-8000MS/8010MS/8500MS

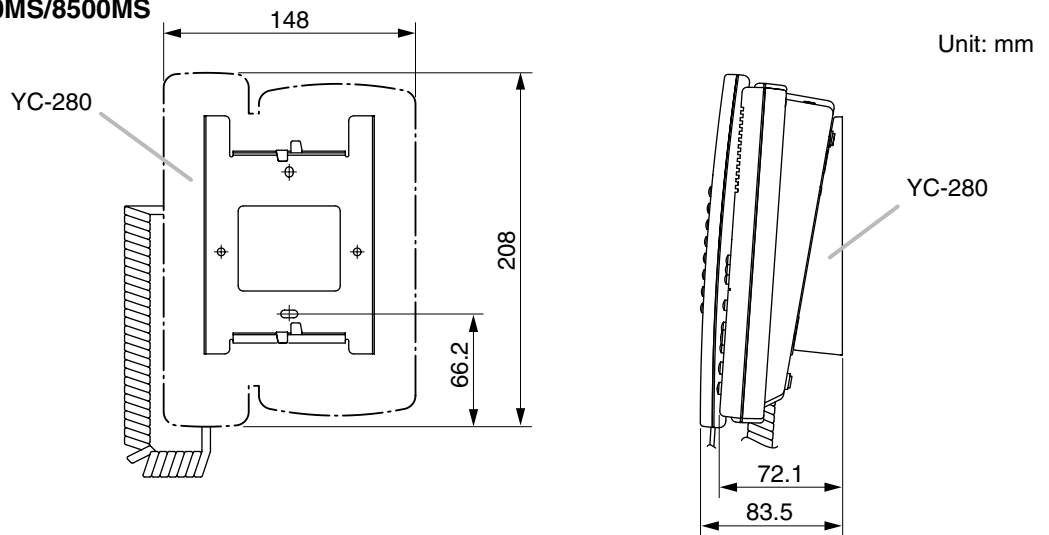

- AN-8020MS

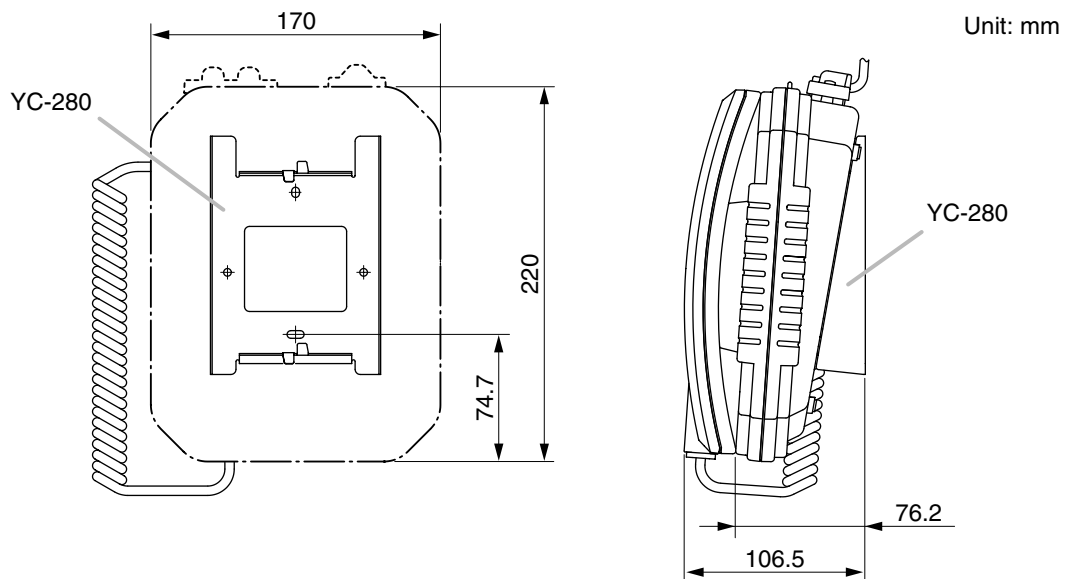

### 3.2.2. AN-8011MS

The station can be mounted on a wall using an optional YC-290 Wall mounting bracket. The YC-290 can be installed to a one-gang electrical box.

#### [Mounting example]

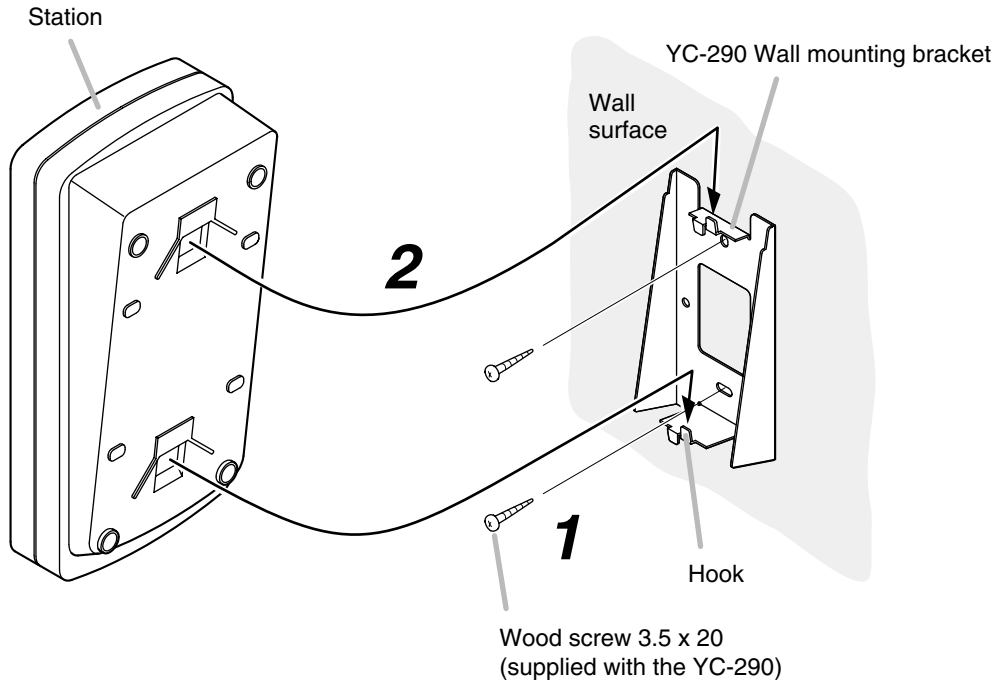

**Step 1.** Install the YC-290 Wall mounting bracket to the wall.

#### Notes

- Use appropriate screws for the construction of wall.
- Wood screws 3.5 x 20 are supplied with the YC-290.
- No fitting screws for electrical box are supplied.  
Use commercially available screws.

**Step 2.** Hang the station on the Wall mounting bracket hook to install.  
Push down the station main body in the direction indicated by the arrow.

[YC-290 dimensional drawing]

Unit: mm

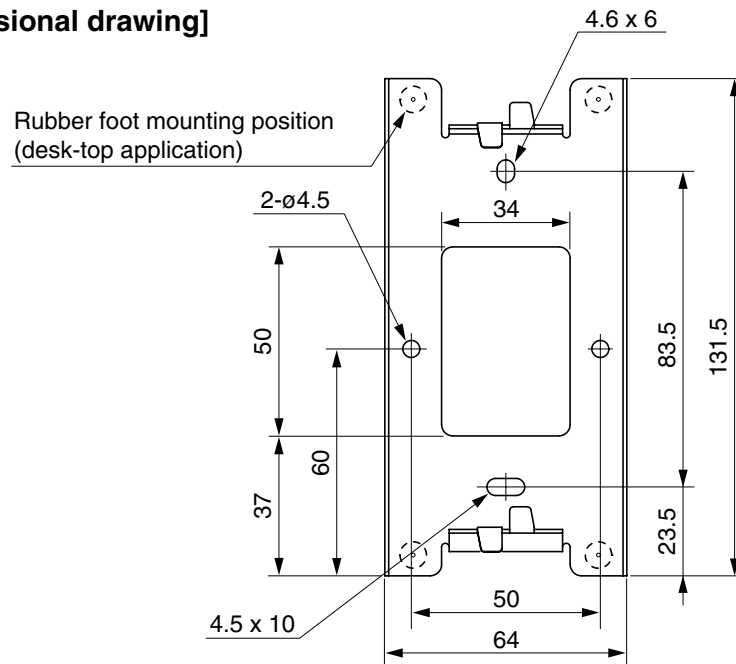

[Installation completion drawing]

- AN-8011MS

Unit: mm

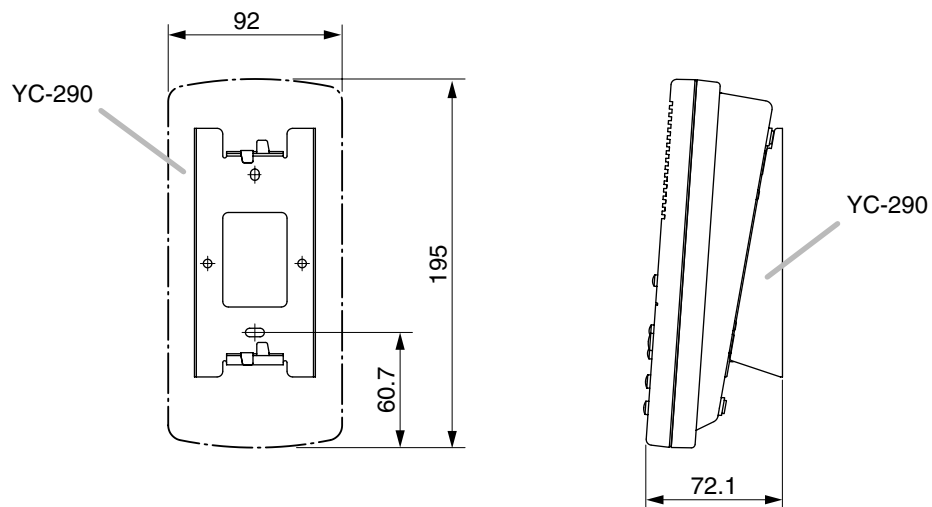



### 3.3. Desk-Top Installation

#### 3.3.1. AN-8000MS/8010MS/8020MS/8500MS

In desktop installations, the front operation panel can be inclined 16° from the desk surface for easier operation by attaching the YC-280 Wall mounting bracket to its bottom surface.

#### [Mounting example]

Hang the wall mounting bracket hook on the station's wall bracket mounting slot to install. Push up the Wall mounting bracket in the direction indicated by the arrow.

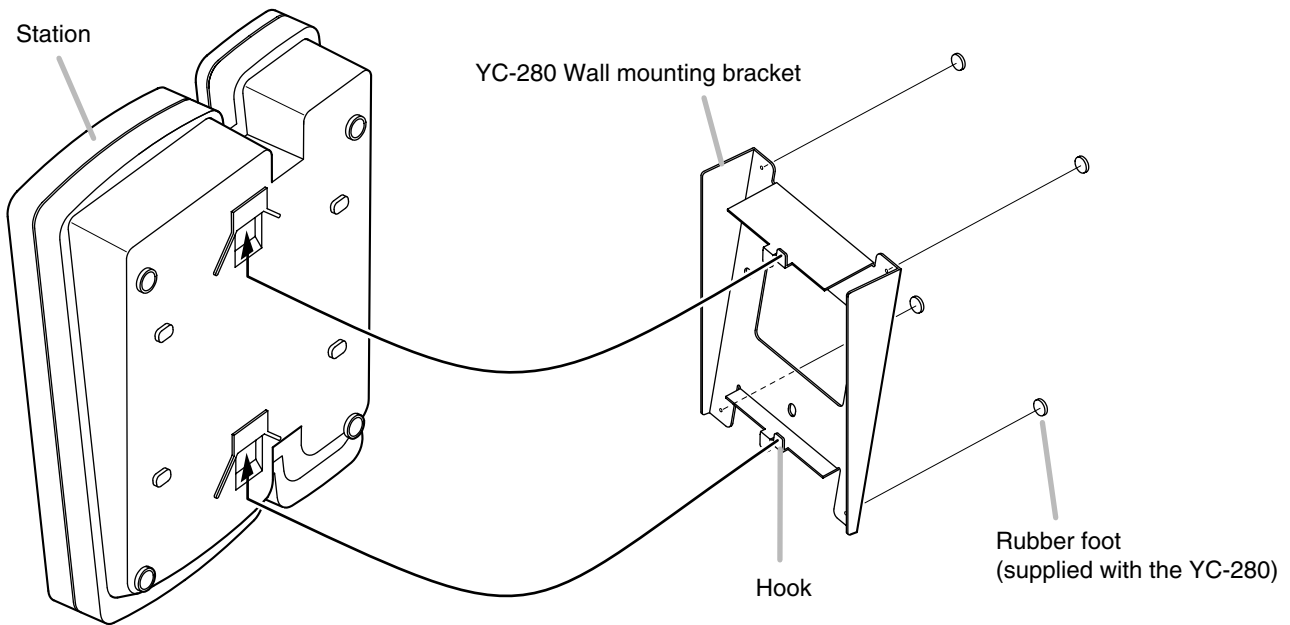

The figure shows the AN-8000MS.

#### [Installation completion drawing]

• AN-8000MS/8010MS/8500MS

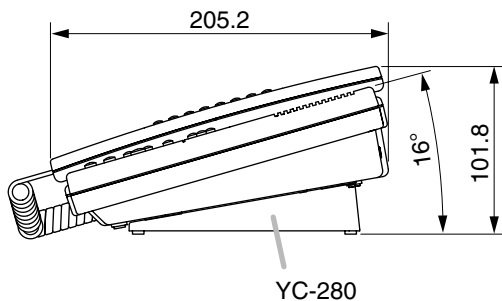

• AN-8020MS

Unit: mm

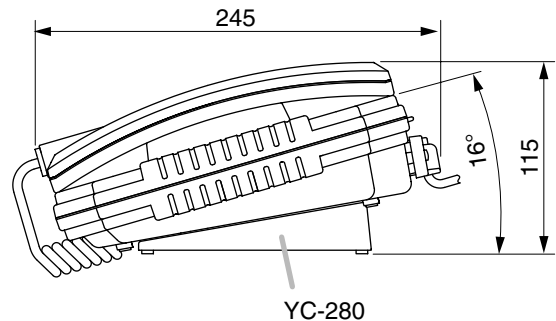

### 3.3.2. AN-8011MS

In desktop installations, the front operation panel can be inclined 16° from the desk surface for easier operation by attaching the YC-290 Wall mounting bracket to its bottom surface.

#### [Mounting example]

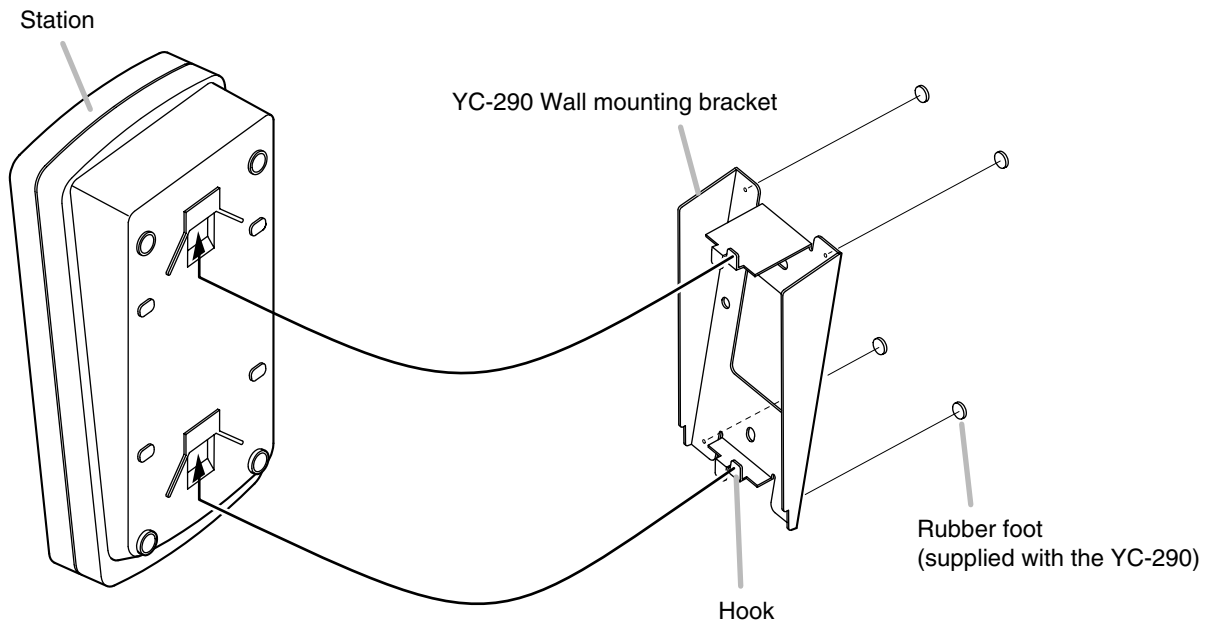

Hang the Wall mounting bracket hook on the station's wall bracket mounting slot to install. Push up the Wall mounting bracket in the direction indicated by the arrow.

#### [Installation completion drawing]

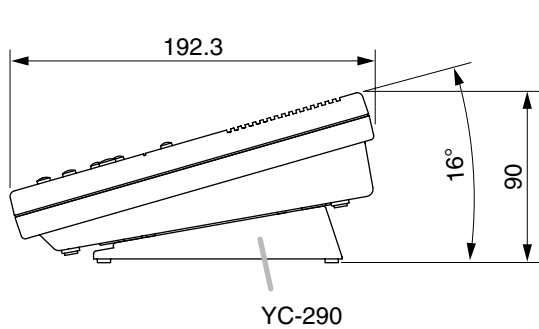

Unit: mm

### 3.4. In-Wall Mounting Using an Electrical Box

#### 3.4.1. AN-8031MS

Attach the AN-8031MS to the YC-241 Back box or an electrical box installed in a wall.

#### Accessory screws

The AN-8031MS comes with 2 types of screws: oval head combination screw M4 x 25 and oval head slotted screw UNC No.6 x 18.

For the electrical box provided with unified threads, use the oval head slotted screws UNC No.6 x 18.

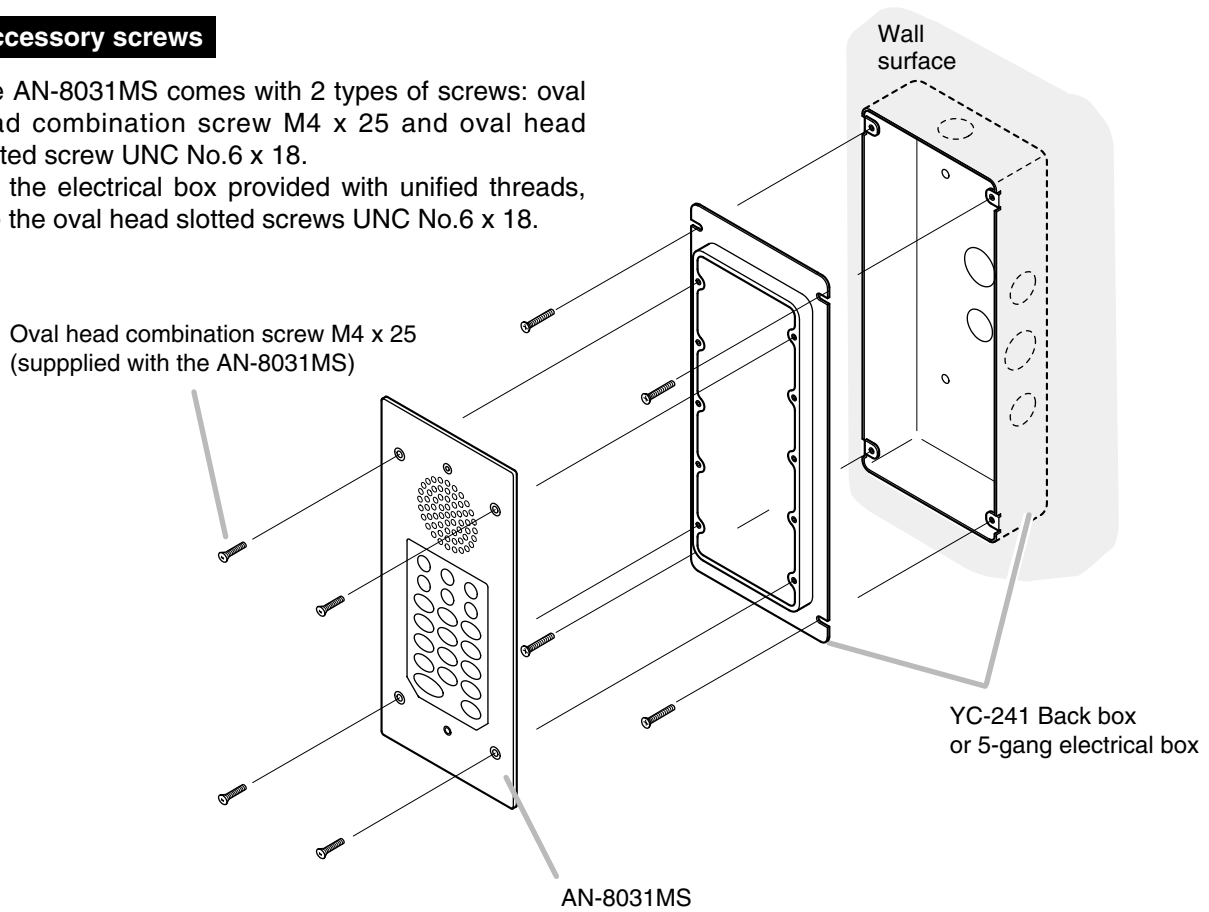

#### Note

The wall should be over 12 mm thick, and the opening in the wall for an electrical box should be under 115 mm (wide) by 254 mm (high).

#### [Installation completion drawing]

Unit: mm

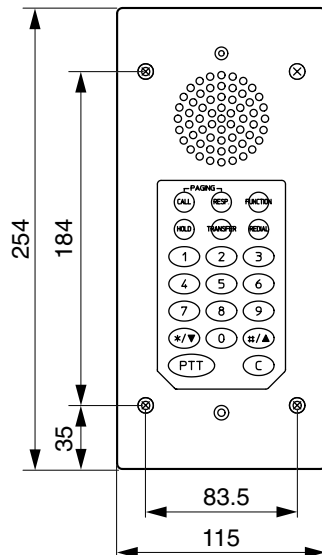

### 3.4.2. AN-8050DS/8540DS

Attach the AN-8050DS/8540DS to the YC-150 Back box or an electrical box installed in a wall.

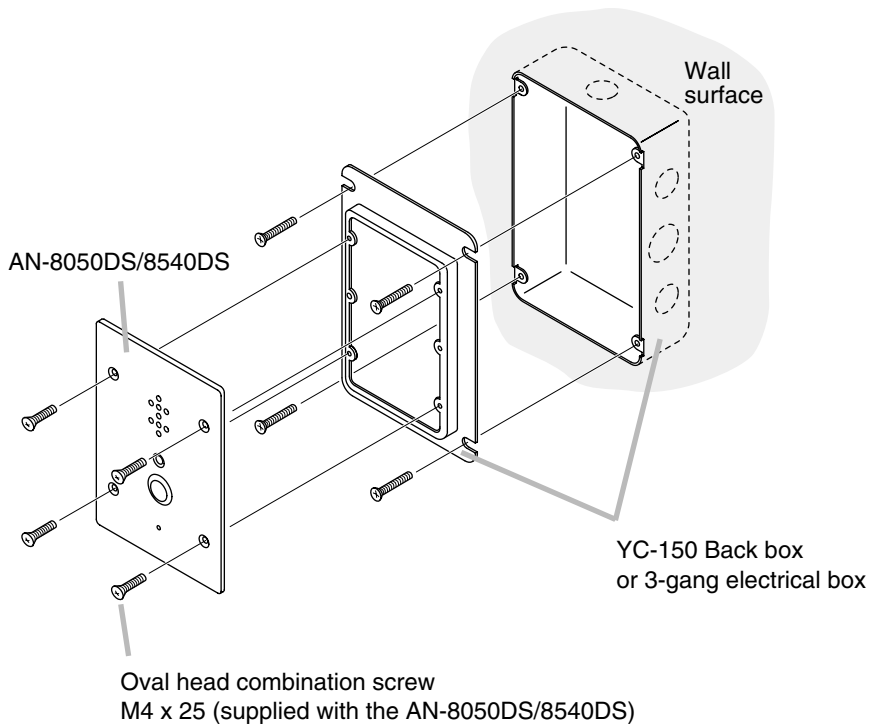

#### [Installation completion drawing]

Unit: mm

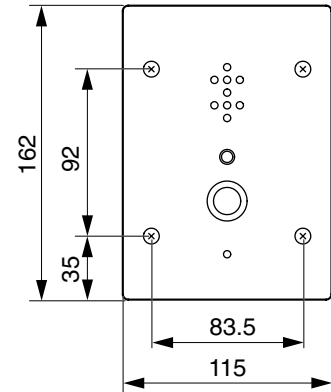

#### Note

The wall should be over 12 mm thick, and the opening in the wall for an electrical box should be under 115 mm (wide) by 162 mm (high).

#### Accessory screws

The AN-8050DS/8540DS comes with 2 types of screws: oval head combination screw M4 x 25 and oval head slotted screw UNC No.6 x 18.

For the electrical box provided with unified threads, use the oval head slotted screws UNC No.6 x 18.

#### Notes

- When controlling an electronic lock with the AN-8050DS/8540DS unit, use "Torx" screws to attach the unit at installation so that it cannot be detached easily.
- When installing the AN-8050DS/8540DS at outdoor or locations where it gets wet with water, tightly seal the panel edges. Besides, provide a weep hole at the underside of the mounting box to permit water to drain off.

Seal the panel edges.

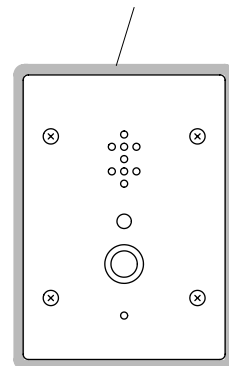

AN-8050DS/8540DS's front panel

### 3.5. On-Wall Mounting Using a Wall-Mount Box

#### 3.5.1. AN-8031MS

Attach the AN-8031MS to the YC-251 Wall-mount box installed on a wall.

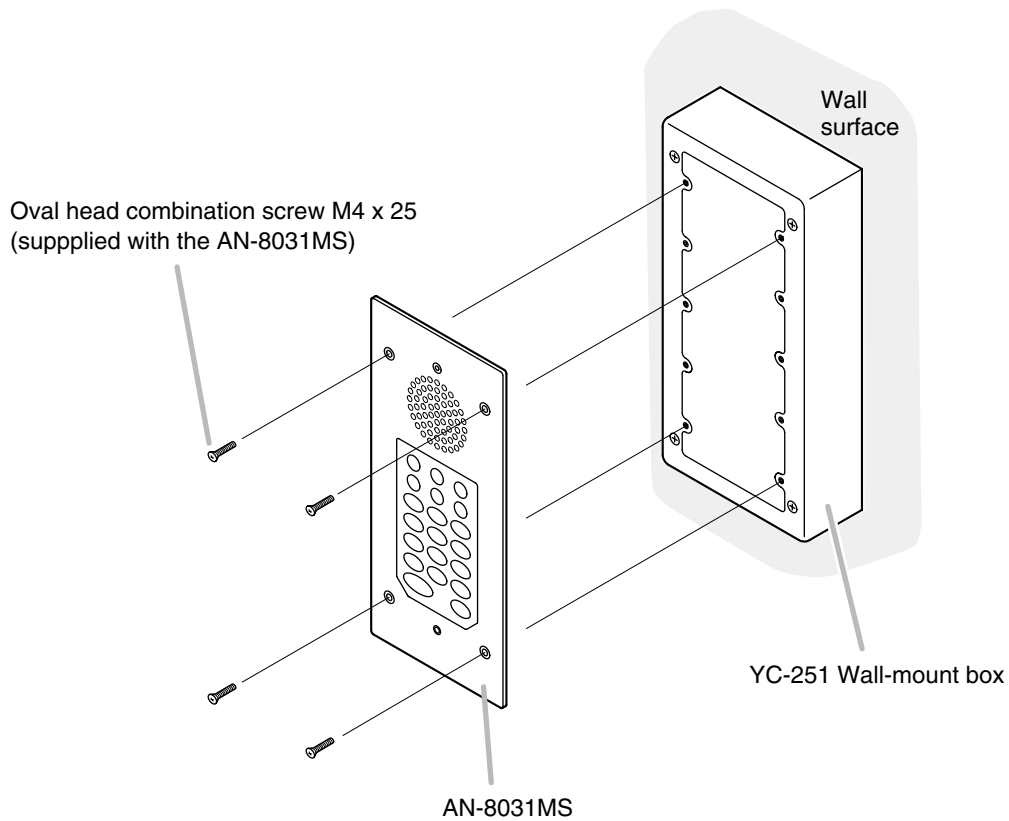

#### Accessory screws

The AN-8031MS comes with 2 types of screws: oval head combination screw M4 x 25 and oval head slotted screw UNC No.6 x 18.

For the electrical box provided with unified threads, use the oval head slotted screws UNC No.6 x 18.

#### [Installation completion drawing]

Unit: mm

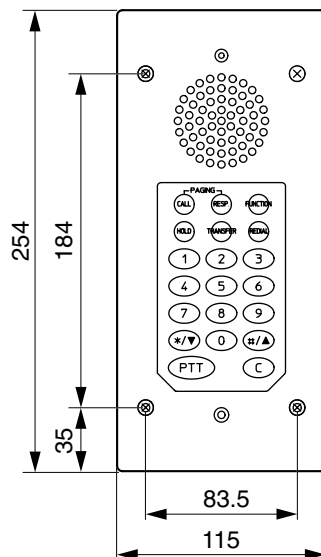

### 3.5.2. AN-8050DS/8540DS

Attach the AN-8050DS/8540DS to the YS-13A Wall-mount box installed on a wall.

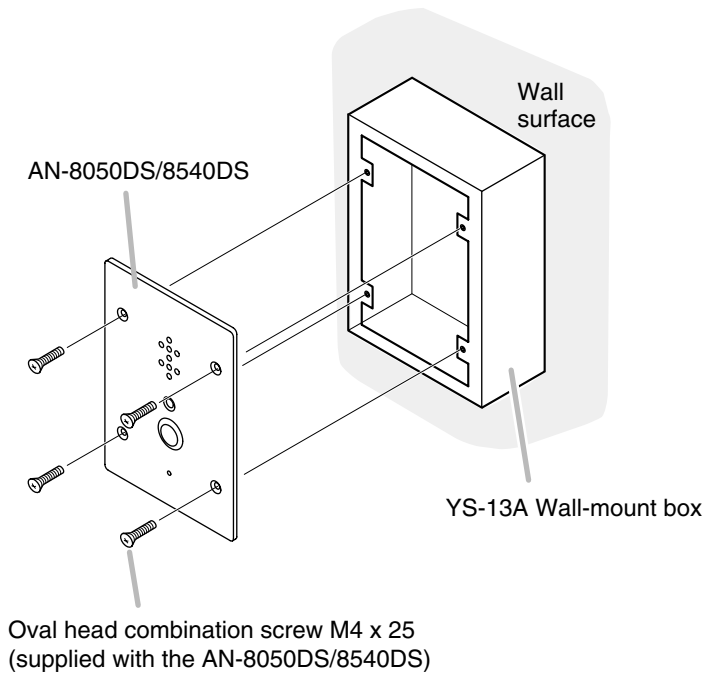

[Installation completion drawing]

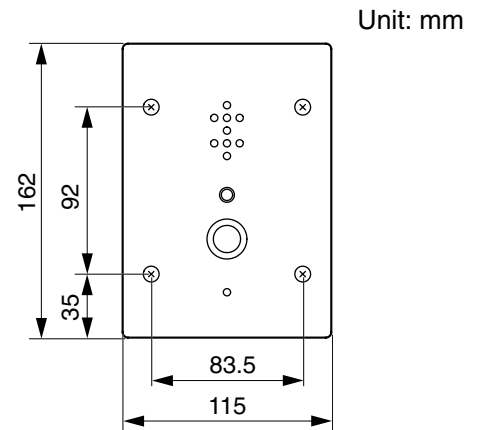

#### Accessory screws

The AN-8050DS/8540DS comes with 2 types of screws: oval head combination screw M4 x 25 and oval head slotted screw UNC No.6 x 18.

For the electrical box provided with unified threads, use the oval head slotted screws UNC No.6 x 18.

#### Notes

- When controlling an electronic lock with the AN-8050DS/8540DS unit, use "Torx" screws to attach the unit at installation so that it cannot be detached easily.
- When installing the AN-8050DS/8540DS at outdoor or locations where it gets wet with water, tightly seal the panel edges. Besides, provide a weep hole at the underside of the mounting box to permit water to drain off.

Seal the panel edges.

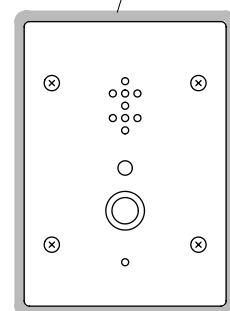

AN-8050DS/8540DS's front panel

## 4. WIRING

### 4.1. Exchange Connection

AN-8000EX Exchange

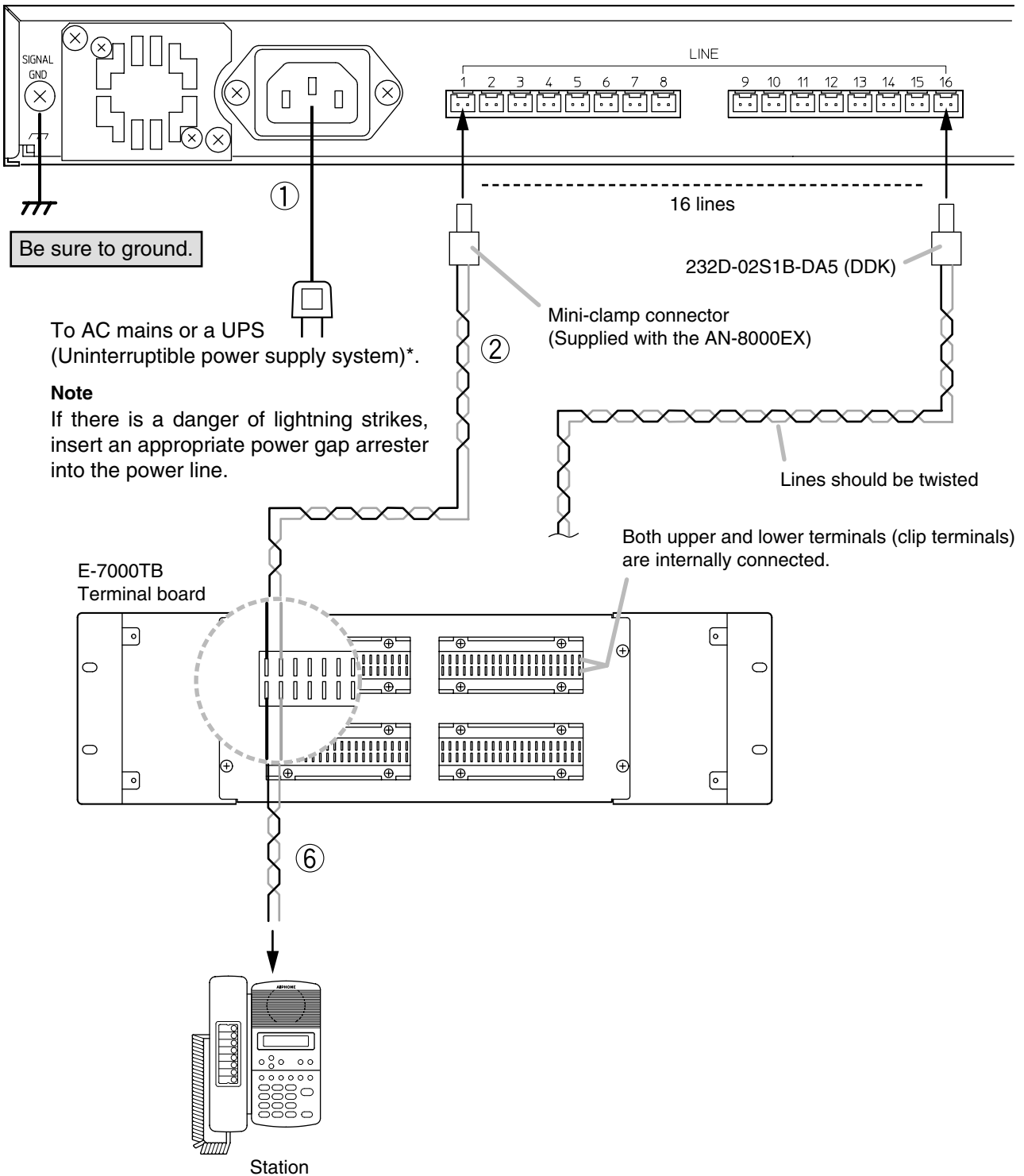

\* Select an appropriate UPS taking into consideration the total power consumption of all system components and the required backup time, and also the requirement that the UPS should employ the on-line power system.

#### Reference

Exchange: 50 W (rated)

8-Port 10M/100M Switching Hub: 10W (Differs depending on products.)

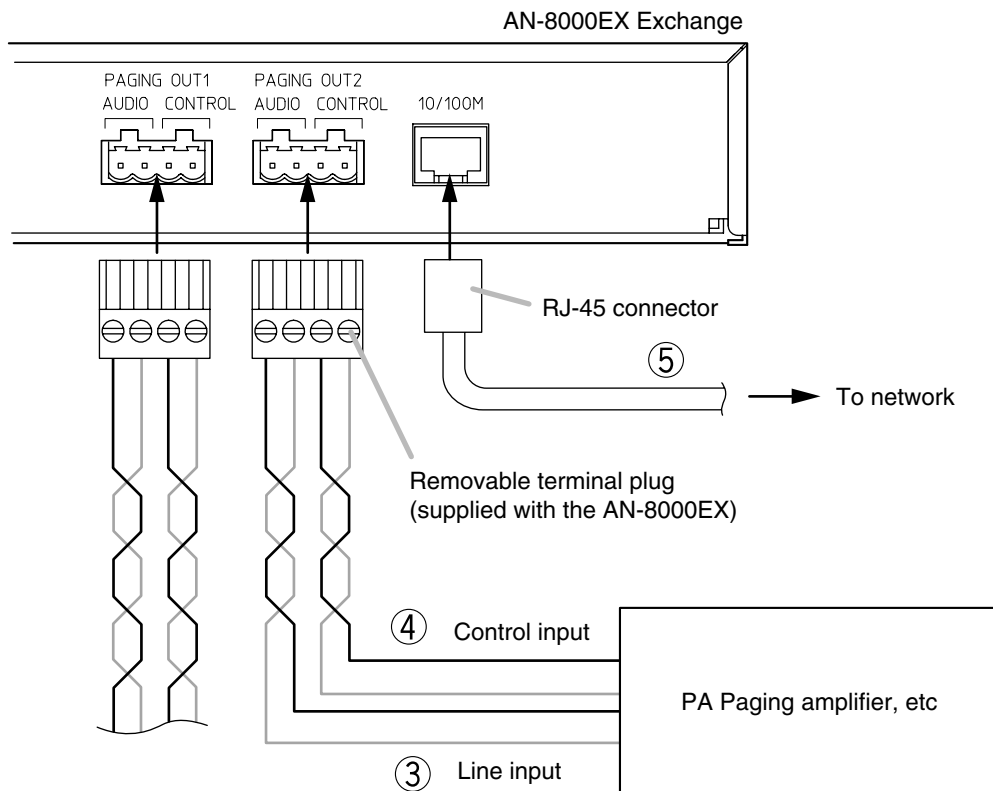

### [General description of connection]

For cables, refer to [p. 3-31](#).

#### 1. Power supply connection

Connect the supplied power supply cord to AC Mains or a UPS (Uninterruptible power supply feeder).

#### About power supply cord handling

The supplied power supply cord is designed for exclusive use with the AN-8000EX.

Use the supplied power supply cord only with the Exchange.

#### 2. Line terminal connection

The line terminals have no polarity.  
(Refer to [p. 3-32](#), Connector connection.)

#### 3. Paging audio output terminal connection

Paging audio output terminals have no polarity.  
(Refer to [p. 3-32](#), Terminal plug connection.)

#### [Specification of paging audio output]

0 dB\*, 600  $\Omega$ , balanced

#### 4. Paging contact output terminal connection

Paging contact output terminals have no polarity.  
(Refer to [p. 3-32](#), Terminal plug connection.)

#### [Specification of paging contact output]

No voltage make contact output  
Withstand voltage: Max. 24 V DC  
Control current: Max. 0.5 A

#### 5. Network connection

Can be connected to a network of 10BASE-T/100BASE-TX in auto-sensing.  
Use a straight through cable of UTP category 5 or more for this connection.

#### 6. Station connection

The connection method differs depending on types of stations. (Refer to [p. 3-21](#), Station Connection.)

\* 0 dB = 1 V



## 4.2. Station Connection

### 4.2.1. Station and Exchange connection

The cables from the AN-8000EX Exchange to the Station have no polarity.

#### [AN-8000MS/8010MS/8011MS]

To connect the cables from the AN-8000EX Exchange to the Master Station, use the connection cable supplied with each station and a commercially available RJ-11 modular jack.

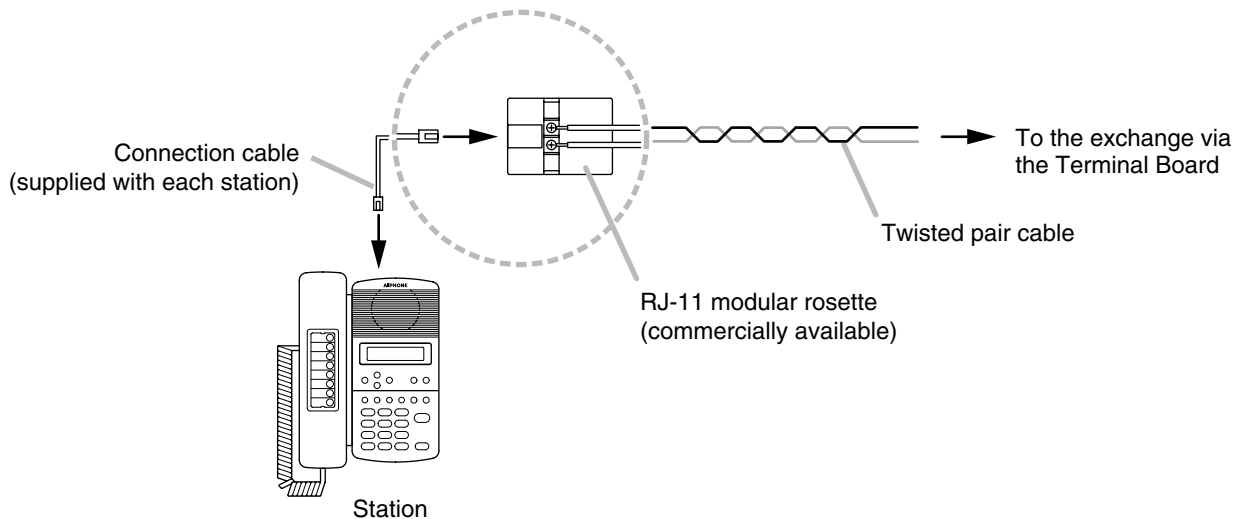

#### [AN-8020MS]

To connect the cables from the AN-8000EX Exchange to the Master Station, use the connection cable directly attached to the station and a commercially available RJ-11 modular jack.

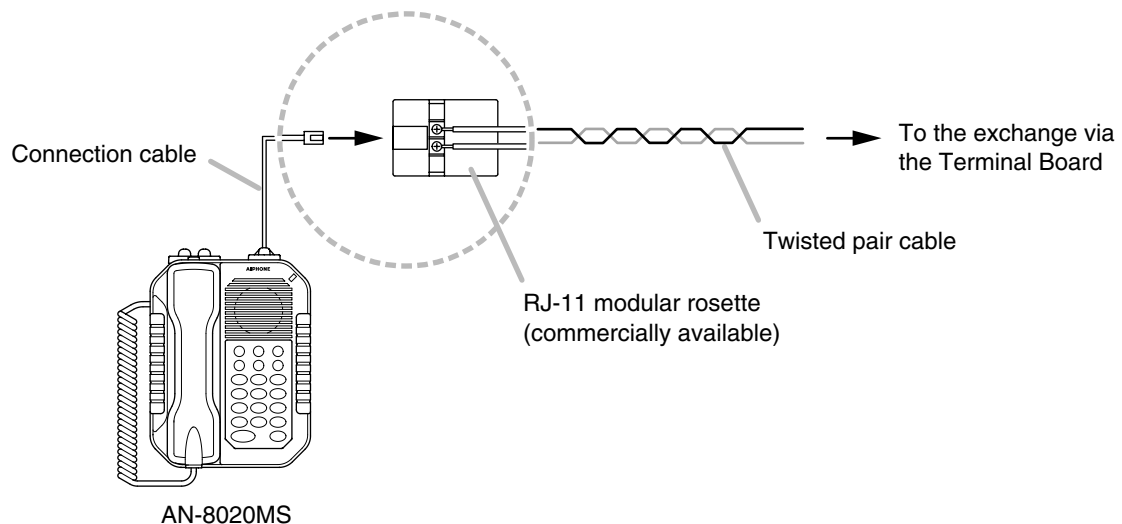

**[AN-8031MS]**

To connect the cables from the AN-8000EX Exchange to the Master station, use the removable terminal plug (2P) supplied with the AN-8031MS.  
Refer to p. 3-32 "Terminal plug connection."

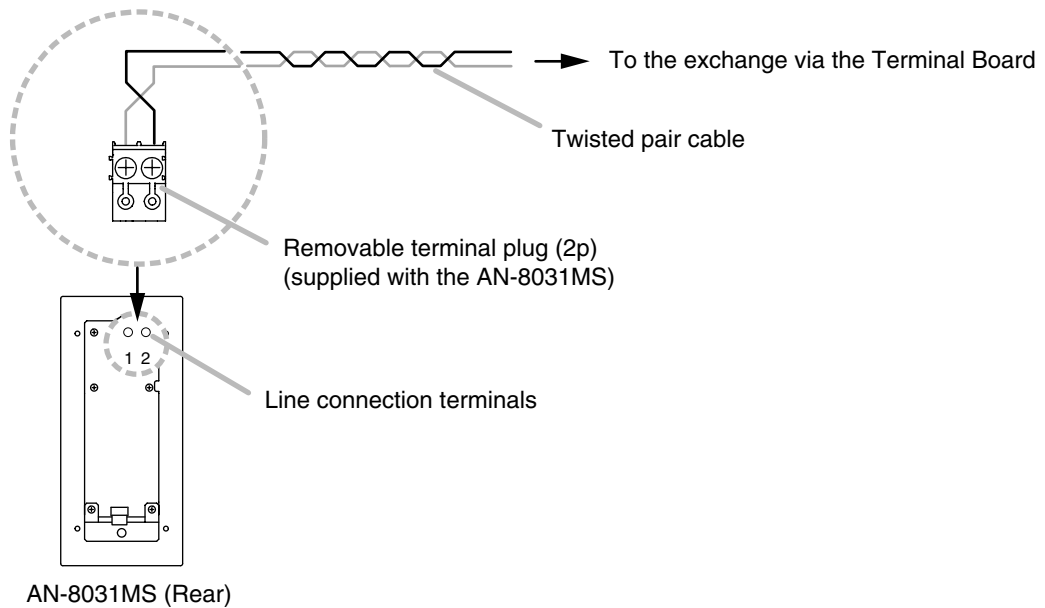

**[AN-8050DS]**

Directly connect the cable coming from the Terminal Board to the AN-8050DS's line connection terminals.  
Refer to p. 3-32 "Terminal plug connection."

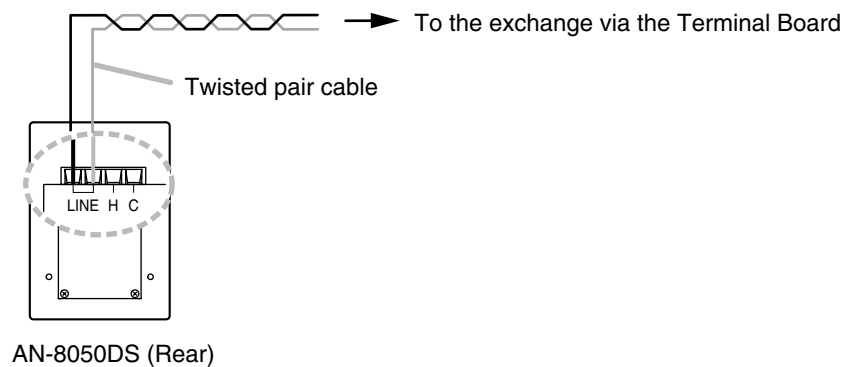

**4.2.2. Headset plug connection (AN-8000MS only)**

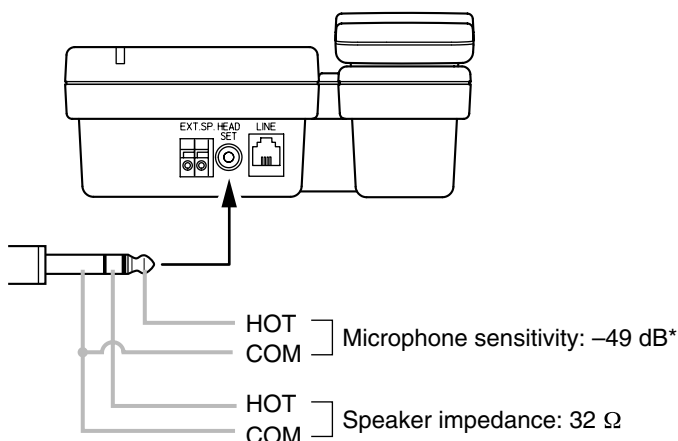

\* 0 dB = 1 V/pa (1 kHz)

### 4.2.3. External speaker terminals and control output terminals connections

#### [AN-8000MS]

These terminals are designed for exclusive connection with external speakers. Press down the desired push-in terminal button on the rear panel with a tip of standard driver, and insert the cable securely.

#### [AN-8020MS]

Follow the procedure below for external speaker terminals and control output terminals connections.

- Step 1.** Remove a protection cover.  
Unscrew the 3 fitting screws securing the protection cover.

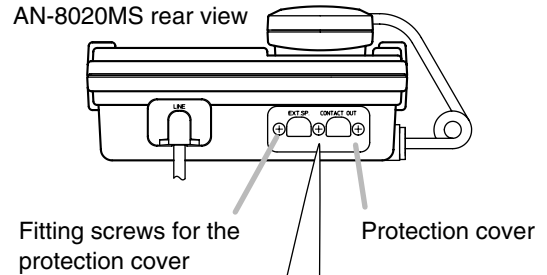

- Step 2.** Pull out a protection cap on the desired terminal.

**Note**  
Do not remove the protection cover on the unused terminal.

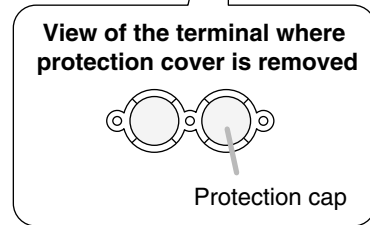

- Step 3.** Run the cable through the protection cover removed, and then connect it to the push-in terminal.

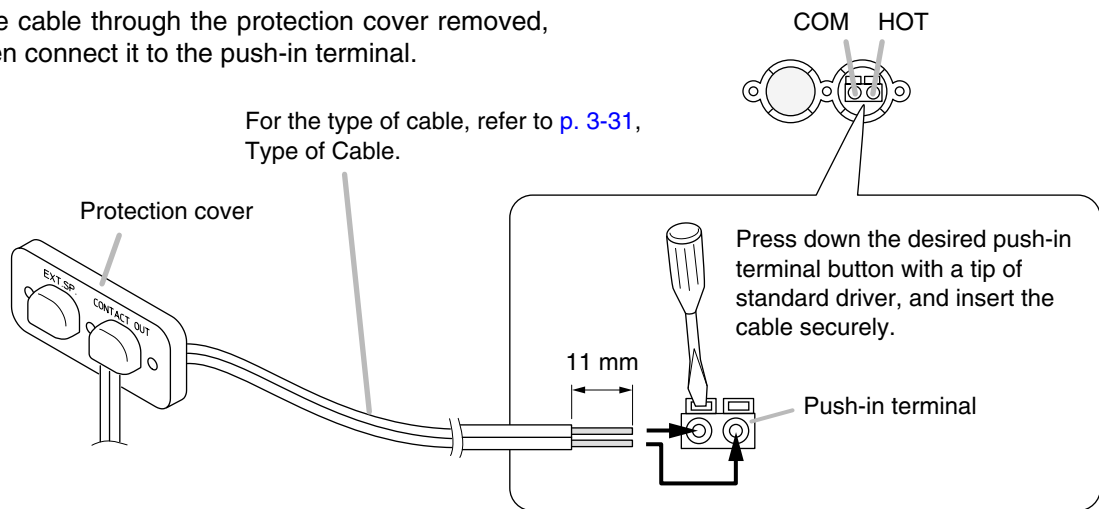

#### [Connection example of control output terminals]

The terminals permit connection of an external device such as an indicator or relay.

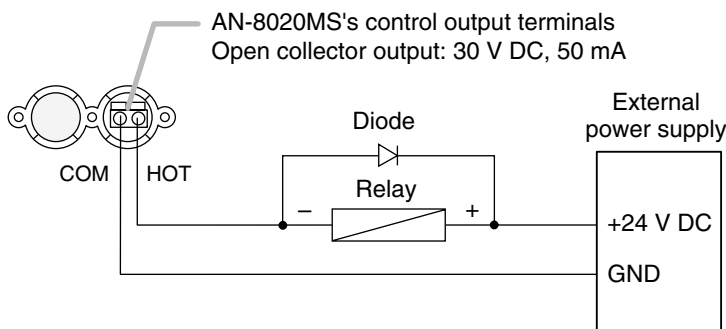

**Step 4.** After inserting the cables in the supplied rubber bushing, insert the bushing into the station, then put the protection cover back in place.

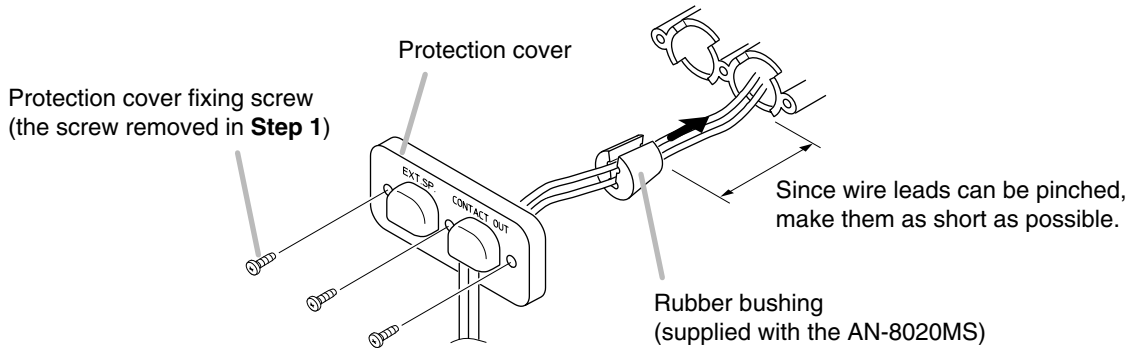

#### 4.2.4. AN-8031MS and RS-191 connections

Connecting the RS-191 Option Handset to the AN-8031MS permits handset conversation.

**Step 1.** Remove the handset jumper attached to the AN-8031MS's handset connection terminal, then insert it to the socket on the RS-191's rear PC board.

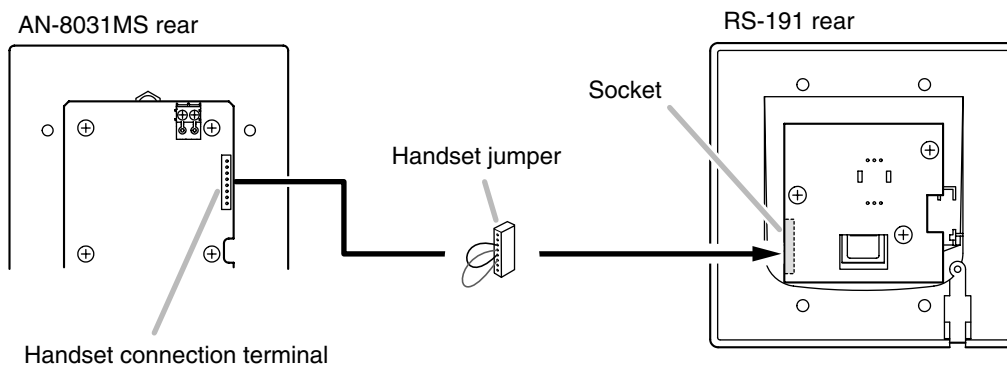

**Note**

Though the socket on the PC board is faced inside, you can insert the handset jumper into the socket from the side.

**Step 2.** Install the ferrite clamp (supplied with the AN-8031MS) onto the RS-191's handset cables. Then, connect the cables to the AN-8031MS's handset connection terminal.

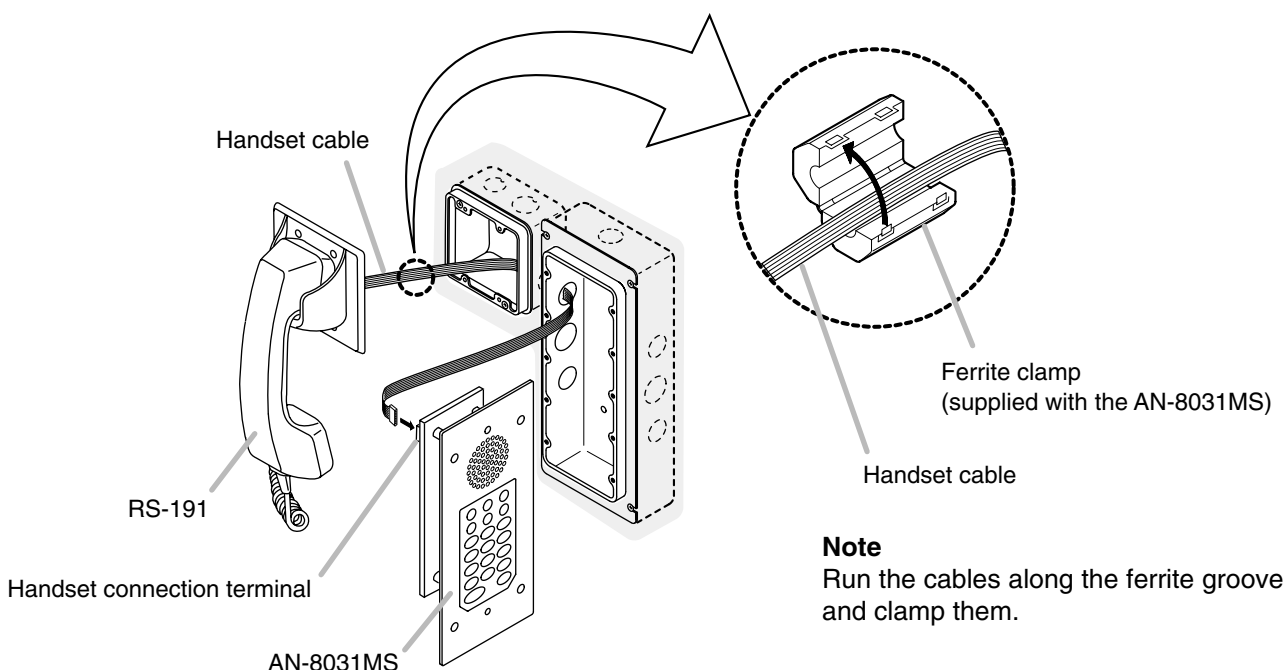

**Note**

Run the cables along the ferrite groove, and clamp them.

#### 4.2.5. AN-8031MS and external switch connections

External switches such as footswitches can be connected to the AN-8031MS's external dial input terminal.

##### Note

The cable length from the external switch should not exceed 3 m.

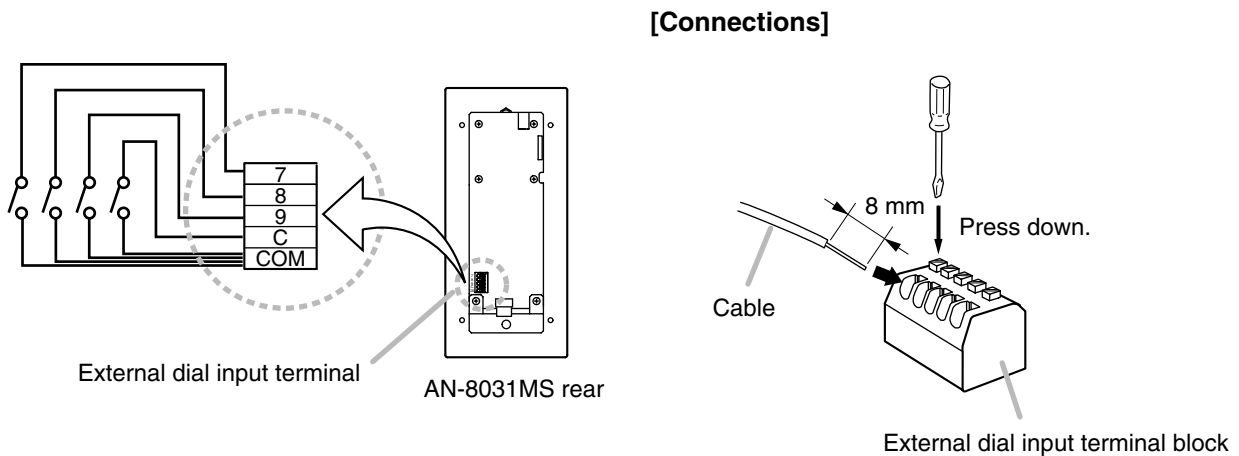

**Note:** For cables, refer to [p. 3-31](#).

Turning on each switch connected to the terminal [7], [8], [9], or [C] permits the same operation as performed by pressing the dial [7], [8], [9], or [C].

For example, the pre-programmed station numbers can be called by pressing the foot switch if one-touch dialing is programmed into these dials.

Refer to [p. 2-10, 5-55](#).

#### 4.2.6. AN-8050DS and external relay connections

An external relay can be connected to the AN-8050DS's external output terminals. (Refer to [p. 3-32](#) "Terminal plug connection.")

These contact outputs can be momentarily shorted by the operation from the conversation party's master station.

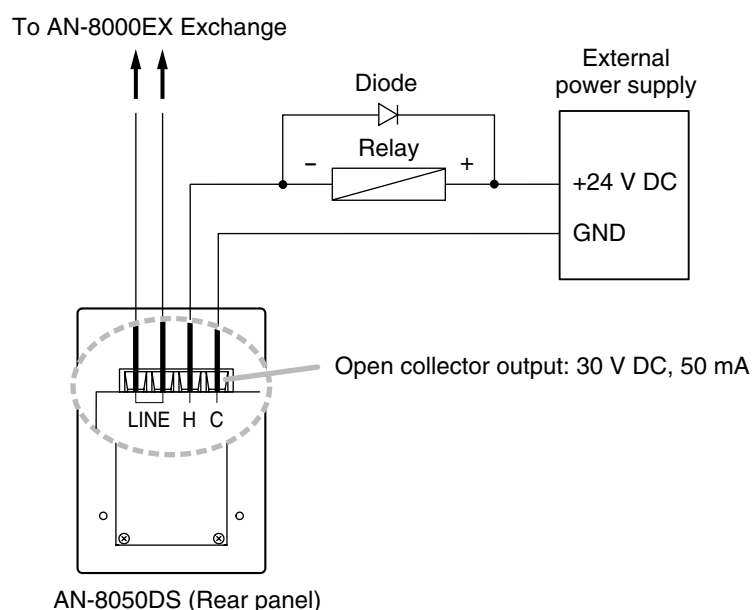

### 4.3. Multi Interface Unit Connection

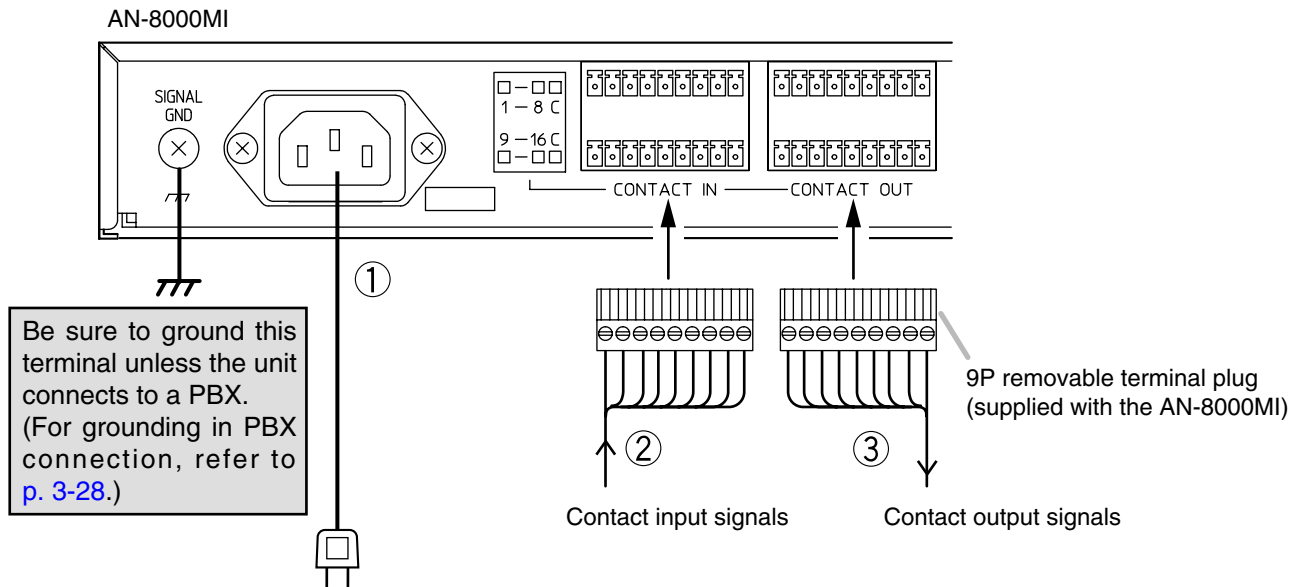

To AC mains or a UPS  
(Uninterruptible power supply system)\*.

#### Note

If there is a danger of lightning strikes, insert an appropriate surge arrester into the power line.

#### [General description of connection]

For cables, refer to p. 3-31.

#### 1. Power supply connection

Connect the supplied power supply cord to AC Mains or a UPS (Uninterruptible power supply).

#### About power supply cord handling

The supplied power supply cord is designed for exclusive use with the AN-8000MI.

Use the supplied power supply cord only with the AN-8000MI.

#### 2. Contact input terminal connection

(Refer to p. 3-32, Terminal plug connection.)

#### [Specification of no-voltage make contact input]

Short-circuit current: 10 mA

Open-circuit voltage: 12 V

#### 3. Contact output terminal connection

Contact output terminals have no polarity.

(Refer to p. 3-32, Terminal plug connection.)

#### [Specification of relay contact output]

Withstand voltage: 24 V DC

Control current: Max. 0.5 A

\* Select an appropriate UPS taking into consideration the total power consumption of all system components and the required backup time, and also the requirement that the UPS should employ the on-line power system.

#### Reference

Multi interface unit: 19 W (rated) for CE version, 16 W (rated) for CU version

8-Port 10M/100M Switching Hub: 10W (Differs depending on products.)

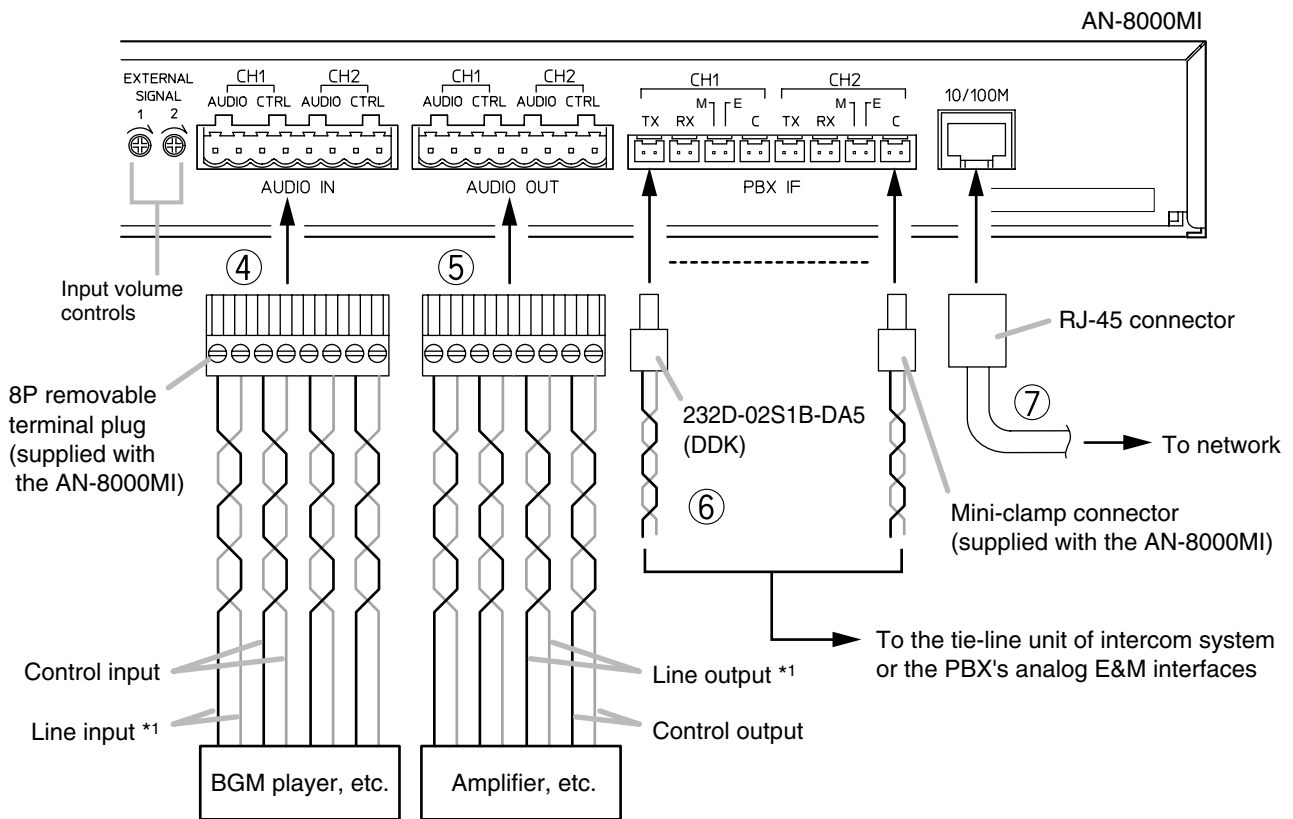

\*1 Connect the Line input cables in a way as shown below according to the type of connected unit's input or output.

- Connecting to a balanced input or output

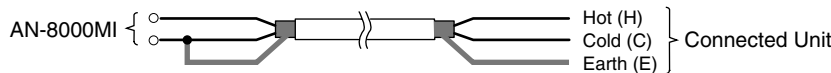

- Connecting to an unbalanced input or output

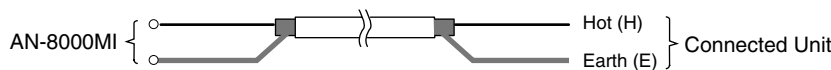

**Note**

You can use only either of the Audio input/output CH1 terminals or the PBX interface CH1 terminal. Likewise, it is the same for CH2.

**4. Audio input terminal connection**

Audio input terminals have no polarity.  
(Refer to p. 3-32, Terminal plug connection.)

**[Specification of audio input]**

Max. 0 dB\*2, over 10 kΩ, balanced  
Audio input sensitivity for each channel can be adjusted in the range of 0 to -25 dB\*2 with the input volume control. Adjust the input sensitivity depending on the equipment to be connected. (Default factory setting: 0 dB\*2)

**[Specification of control input]**

No-voltage make contact  
Short-circuit current: 10 mA  
Open-circuit voltage: 12 V

**5. Audio output terminal connection**

Audio output terminals have no polarity.  
(Refer to p. 3-32, Terminal plug connection.)

**[Specification of audio output]**

Max. 0 dB\*2, under 600 Ω, balanced

**[Specification of control output]**

Relay contact output  
Withstand voltage: 24 V DC  
Control current: Max. 0.5 A

**6. PBX interface terminal connection**

Differs depending on the connections to the PBX exchange via the analog E&M interface.  
(Refer to p. 3-28 for the connection method.)  
(Refer to p. 3-32, Connector connection.)

**7. Network connection**

Can be connected to a network of 10BASE-T/100BASE-TX in auto-sensing.  
Use a straight through cable of UTP category 5 or more for this connection.

\*2 0 dB = 1 V

**[Connecting to the PBX's analog E&M interface]**

Connect the PBX's transmitting line to the unit's RX terminal, and the PBX's receiving line to the TX terminal. Also connect the PBX's M (Mouth) line to the unit's E (Ear) terminal, and the PBX's E line to the M terminal.

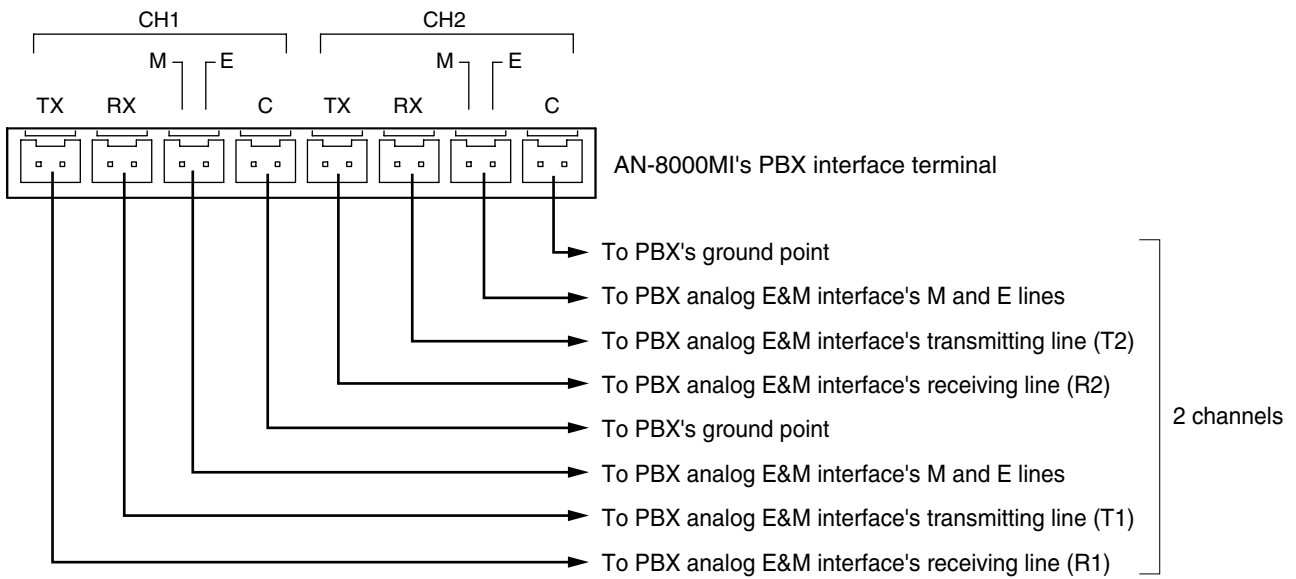
**Notes**

- The "C" terminals for CH1 and CH2 are internally connected to the unit body (functional earth terminal).
- Do not ground the Functional earth terminal (No. 6 on p. 1-11) in this PBX connection.

**Tips**

- Output level and input sensitivity can be adjusted in the range of 0 to 15 dB depending on the equipment to be connected and cable length. (Refer to p. 5-38.)
- The Line attribute (Address signaling) and Line start method (Start dial supervision signaling) can be set for the connected equipment. (Refer to p. 5-38.)



## 4.4. IP Station Connection

### 4.4.1. AN-8500MS connections

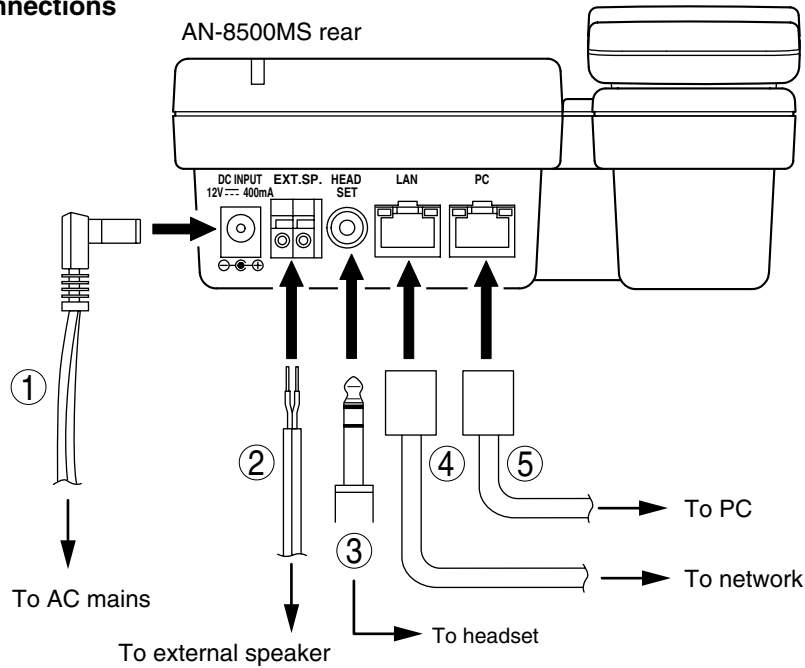

#### 1. AC adapter terminal connection

Connect the AC adapter\*.  
Install the supplied ferrite clamp on the AC adapter cable by winding the cable around the ferrite clamp once.

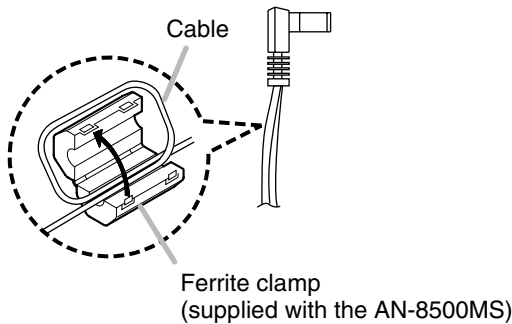

\* Use the AC adapter AD-1210P (optional) or the equivalent.  
As for the usable adapter, consult your AIPHONE sales office.

#### 2. External speaker terminal connection

Press down the desired push-in terminal button with a tip of standard driver, and insert the cable securely.

For the type of cables, refer to p. 3-31, Type of Cable.

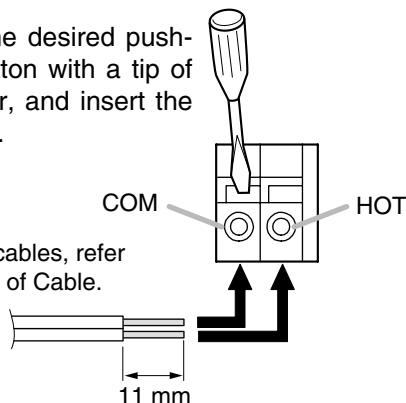

#### Note

When using the external speaker, set the internal/external speaker switch on the bottom to the EXT. SP position.

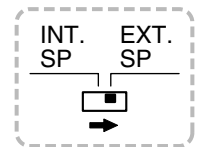

#### 3. Headset plug connection

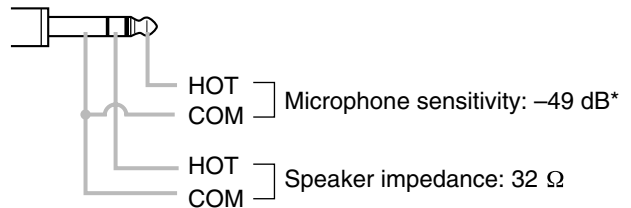

#### 4. Network connection terminal connection

Can be connected to a network of 10BASE-T/100BASE-TX in auto-sensing.  
Connecting the station to a PoE (Power over Ethernet) switching hub compliant with IEEE802.3af eliminates the need for an AC adapter. (For connection, refer to the instruction manual supplied with the switching hub.)  
Use a straight through cable of UTP category 5 or more for this connection.

#### 5. PC connection terminal connection

A PC can be cascaded with the station. If power is not supplied to the station, hub function will not work.  
Use a straight through cable of UTP category 5 or more for this connection.

**Note:** Be sure to connect one PC only.

\* 0 dB = 1 V/pa (1 kHz)

## 4.4.2. AN-8540DS connection

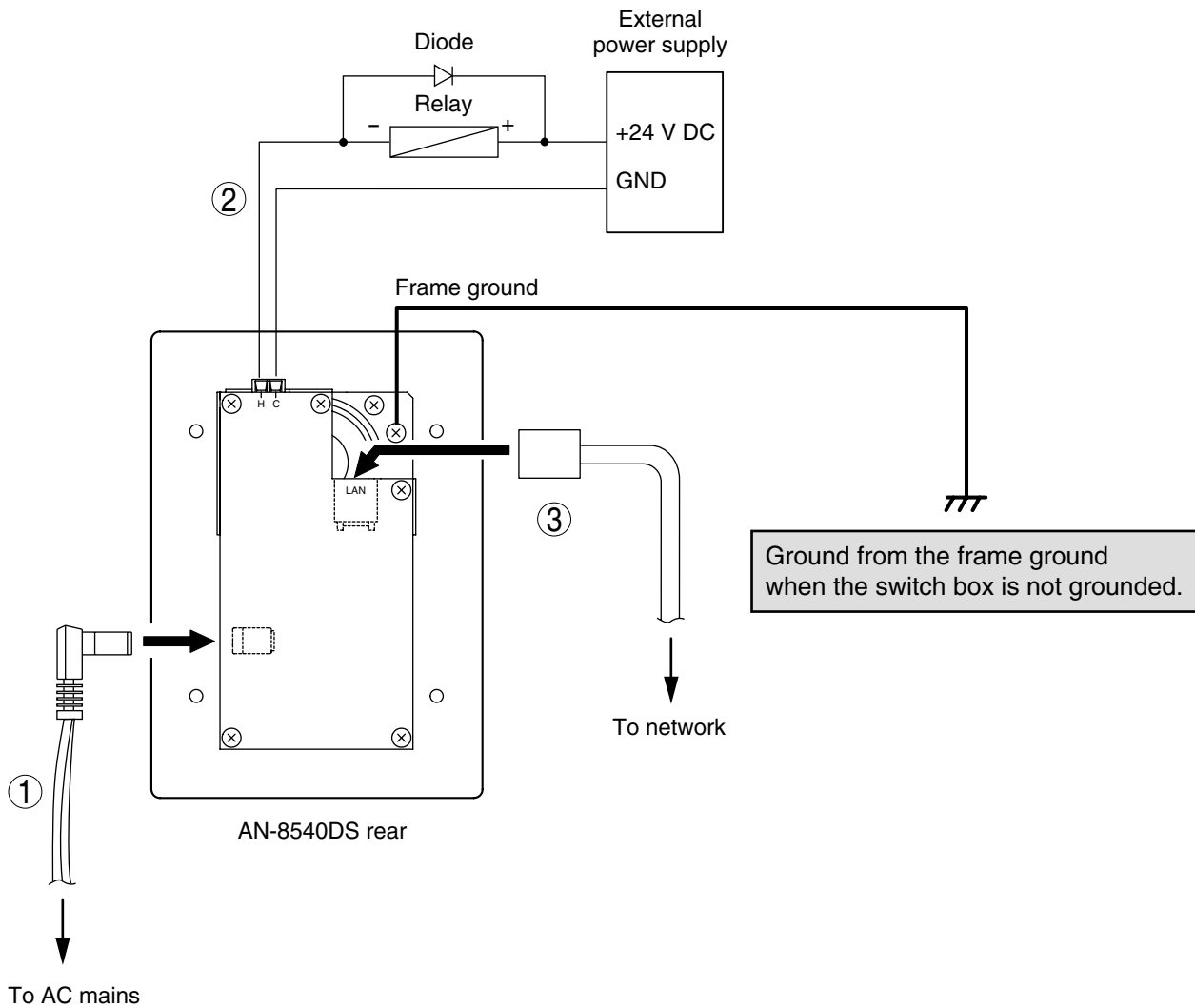
**1. AC adapter terminal connection**

Connect the AC adapter\*.

\* Use the AC adapter AD-1210P (optional) or the equivalent.

As for the usable adapter, consult your AIPHONE sales office.

**2. Contact output terminal connection**

An external relay can be connected as illustrated above.

(Refer to p. 3-32, Terminal plug connection.)

**[Specification of contact output]**

Open collector output

Withstand voltage: Max. 30 V DC,

Control current: Max. 50 mA

**3. Network connection terminal connection**

Can be connected to a network of 10BASE-T/100BASE-TX in auto-sensing.

Connecting the station to a PoE (Power over Ethernet) switching hub compliant with IEEE802.3af eliminates the need for an AC adapter. (For connection, refer to the instruction manual supplied with the switching hub.)

Use a straight through cable of UTP category 5 or more for this connection.

Install the ferrite clamp (supplied with the AN-8540DS) on the network cable.

Ferrite clamp  
(supplied with the AN-8540DS)

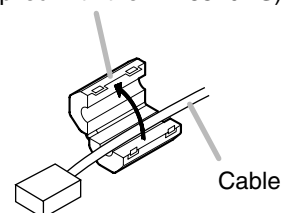

## 4.5. Type of Cable

The types of cables are to be determined according to the following conditions.

To use twisted pair wires (such as those used for electronic push-button telephone) for wiring between the Exchange and the stations, and for connections to the Multi interface unit's audio input/output terminals and PBX interface terminals.

Use a straight through cable of UTP category 5 or more with RJ-45 connector for wiring the equipment to IP network.

The number of cables pairs laid should be determined considering the possibility of future expansion of the system.

Outdoor wires should be used where wiring passes through inaccessible areas such as ceilings or under floors where the maintenance is not performed. Indoor wires may also be used, however, in case where there is no risk of deterioration due to exposure to heat, etc.

### Note

Specifications related to each junction are as follows.

Mini-clamp connector (AN-8000EX line terminal and AN-8000MI PBX interface terminal)

Conductor diameter:  $\varnothing$  0.4 – 0.65 mm (AWG22 – 26), Solid wire

Outside diameter:  $\varnothing$  1.05 mm or below

Clip terminal (E-7000TB)

Conductor diameter:  $\varnothing$  0.4 – 0.8 mm (AWG20 – 26), Solid wire

Outside diameter:  $\varnothing$  1.5 mm or below

Removable terminal plug (AN-8000EX Paging output and AN-8000MI Control I/O and Audio I/O terminals)

Conductor diameter:  $\varnothing$  0.5 – 2 mm (AWG12 – 24), Solid wire/Stranded wire

Removable terminal plug (AN-8031MS line terminal)

Conductor diameter:  $\varnothing$  0.4 – 1.6 mm (AWG14 – 26), Solid wire/Stranded wire

External speaker terminal (AN-8000MS/8500MS)

Conductor diameter:  $\varnothing$  0.4 – 1.3 mm (AWG16 – 26), Solid wire

$\varnothing$  0.7 – 1.4 mm (AWG16 – 22), Stranded wire

External speaker terminal, Control output terminal (AN-8020MS)

Conductor diameter:  $\varnothing$  0.65 mm (AWG22), Solid wire

$\varnothing$  0.7 mm (AWG22), Stranded wire

External dial input terminal (AN-8031MS)

Conductor diameter:  $\varnothing$  0.8 – 1.3 mm (AWG16 – 20), Solid wire/Stranded wire

Station terminal (AN-8050DS line terminal, contact output terminal, AN-8540DS contact output terminal)

Conductor diameter:  $\varnothing$  0.4 – 1.3 mm (AWG16 – 20), Solid wire/Stranded wire

## 4.6. Relations Between Core Diameter of Cable and Maximum Cable Length

Refer to the following chart as guidelines when designing the distance between the Exchange and stations so that loop resistance value becomes 170  $\Omega$  or less.

Conductor diameter (mm)	Loop resistance ( $\Omega$ /km)	Maximum cable length between the Exchange and station. (Assuming that the loop resistance is 170 $\Omega$ )
$\varnothing$ 0.4	295	570 m
$\varnothing$ 0.5	187	900 m
$\varnothing$ 0.65	113	1.5 km
$\varnothing$ 0.9	58	2.9 km

## 4.7. Connector Connection

### 4.7.1. Mini-clamp connector connection

Connect the mini-clamp connector supplied with the AN-8000EX or the AN-8000MI to a cable using a commercially available tool (pliers).

**Step 1.** Cut off two-cable ends in equal length, and insert them securely to a cover section (transparent side) of the mini-clamp connector.

**Note**

Insert the cable without stripping the cable jacket.  
For cables, refer to [p. 3-31](#), Type of Cable.

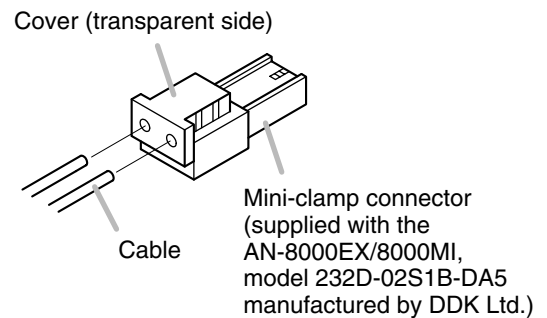

**Step 2.** With a pair of pliers, lightly pinch the mini-clamp cover and, after ensuring that the cable is securely inserted, firmly squeeze on the cover.

**Note**

Squeeze on the mini-clamp cover until it is correctly locked.

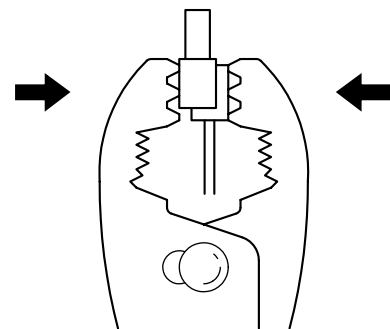

**Step 3.** Insert the wired connector (plug) into the exchange's connector (socket) until it locks into place.

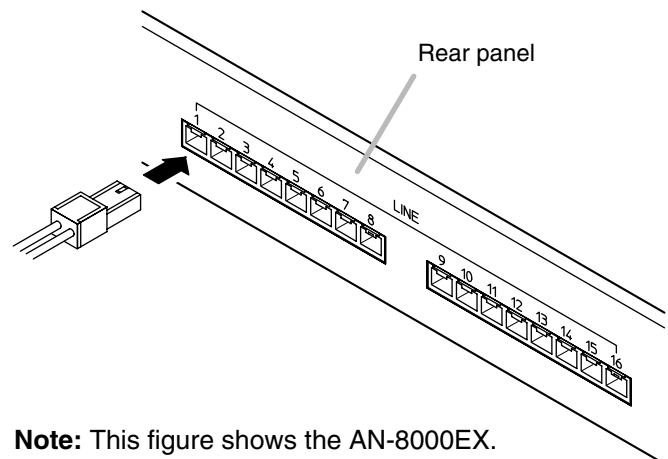

**Note:** This figure shows the AN-8000EX.

### 4.7.2. Terminal plug connection

**Step 1.** Strip a cable jacket of approx. 7 mm (approx. 5 mm for the AN-8031MS only) from the cable end.

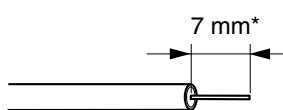

\* Approx. 5 mm for the AN-8031MS

For cables, refer to [p. 3-31](#), Type of Cable.

**Note**

Do not solder plate on exposed inner cables when using a stranded wire.

**Step 2.** Loosen the terminal screws and insert the cables.

**Step 3.** Tighten the terminal screws securely.

**Notes**

- Tug lightly on the cable to be sure that it does not pull free. If the cable pulls free, loosen the terminal screw again and reconnect from **Step 2**.
- Use the screwdriver appropriate to the screws tightened into the terminal plug.

**Step 4.** (Removable terminal plug only)

Insert the wired terminal plug into the terminal block or the pin header.

[AN-8000EX]

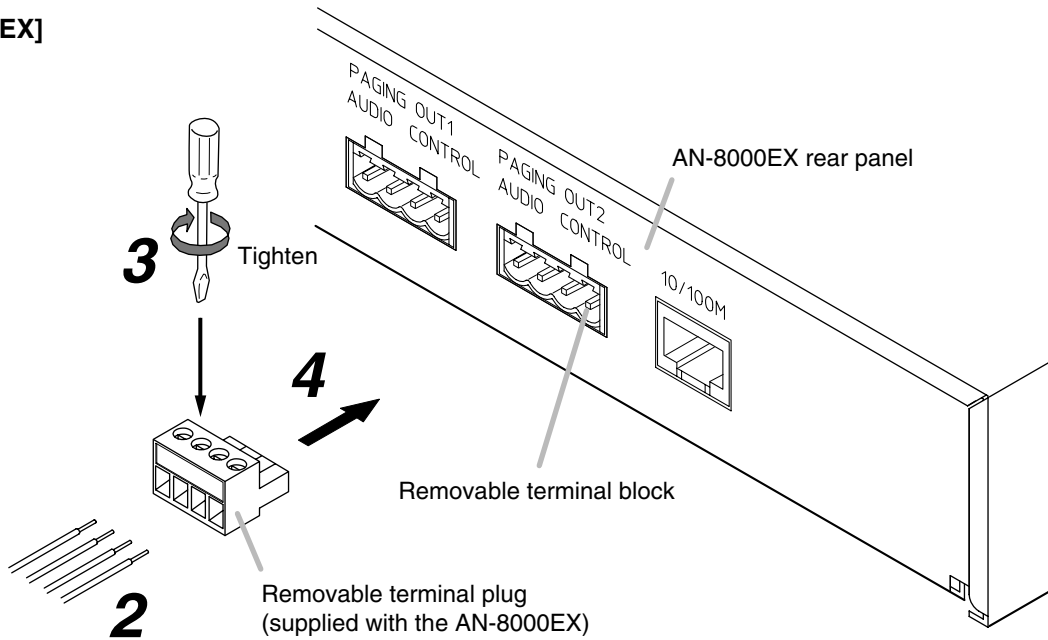

**Note:** This terminal connection method also applies to the AN-8000MI.

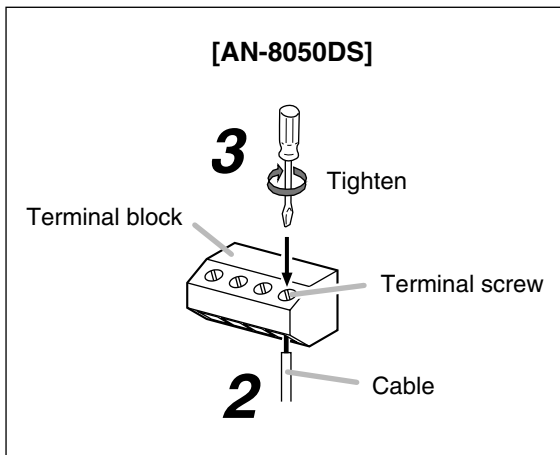

**Note**

This terminal connection method also applies to the AN-8540DS.

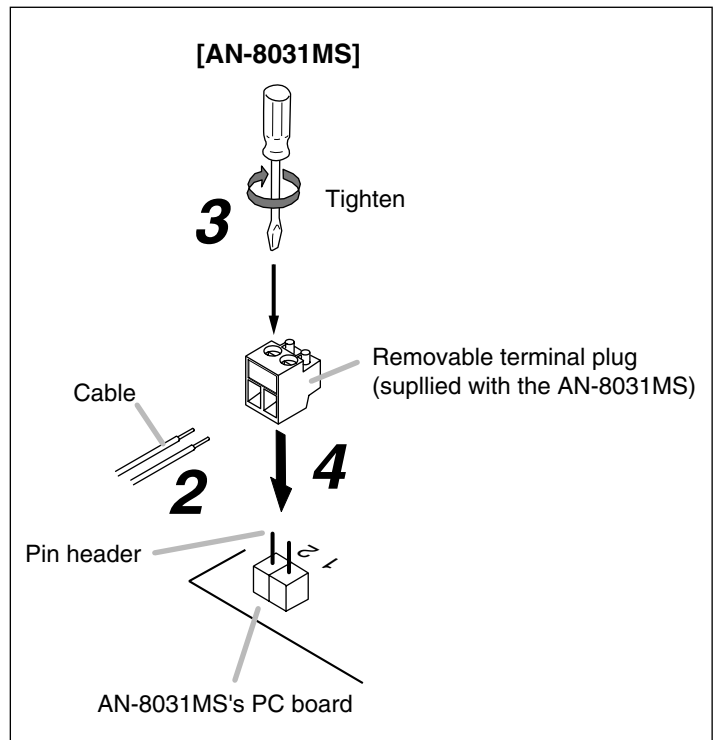

## 4.8. E-7000TB Terminal Board Wiring

For cable connection to the E-7000TB Terminal Board use the optional YC-105, clipping tool. Hook the end of the cable onto the terminal and, with the cable end in hand, press the YC-105 Dedicated Tool down onto the terminal from above. Pressing down the YC-105 tool cuts off the excess cable end, securing the connection.

For cables, refer to [p. 3-31](#), Type of Cable.

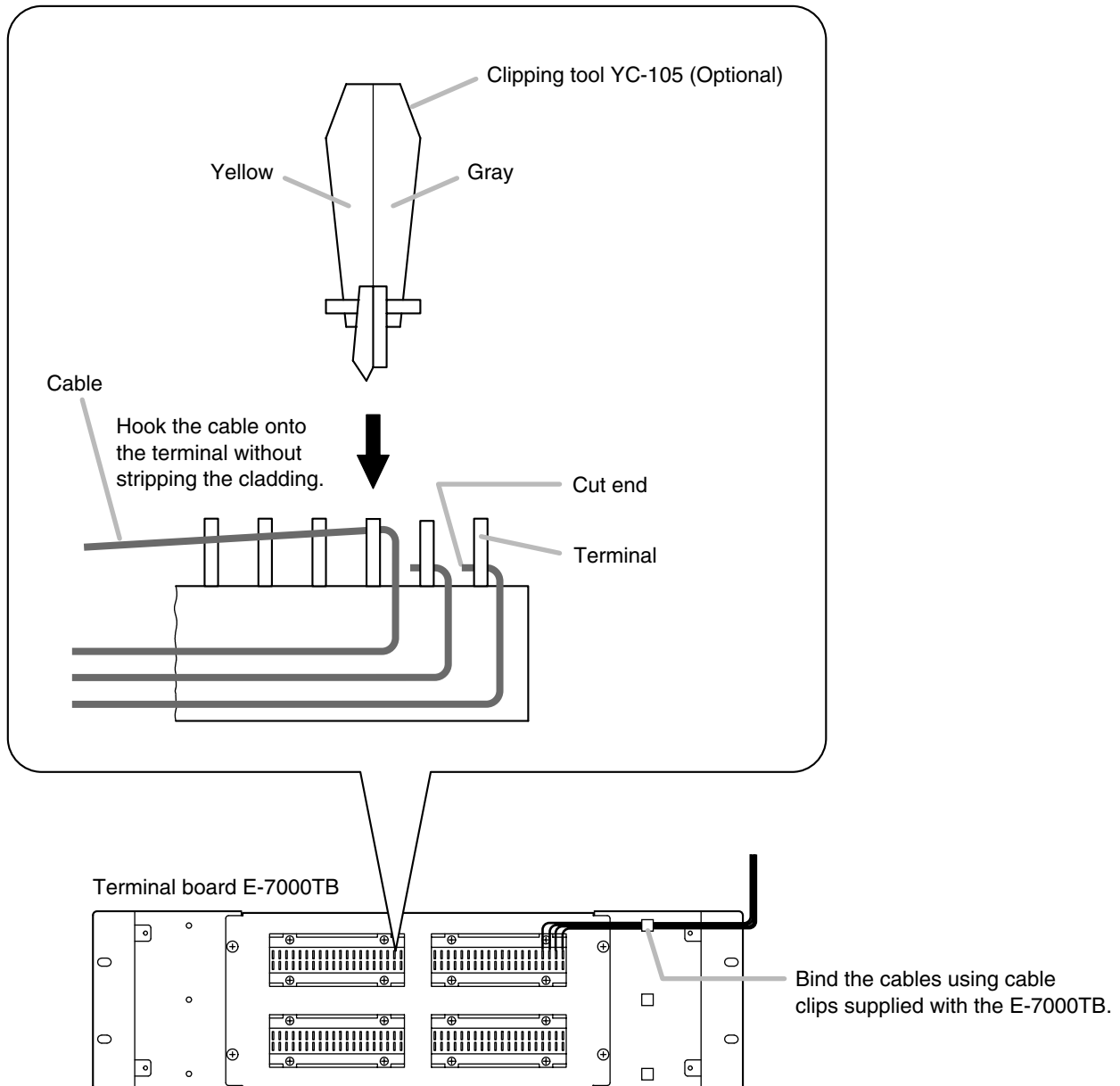

# ***Chapter 4***

---

## ***BEFORE PERFORMING SYSTEM SETTINGS...***

This chapter describes system setting items and switching on power to the system.

## 1. SYSTEM SETTING ITEMS AND DEFAULT

All system setting items except the auto-dialing programming can be set using the AN-8000 software. Some setting items, however, can also be set on the browser or at stations. The browser can only make the connected Exchange-, Multi interface unit-, or IP station-related items, while stations can only make the connected Exchange- or their own stations-related items.

The following tables, classified according to the system setting items on the AN-8000 software, show items, their default, and reference pages in this manual.

### Note

For reference pages, "SW" represents the software, "BR" represents the browser, and "ST" represents a station.

### 1.1. General System

Item	Setting from Software	Setting from browser	Setting from station	Default	Reference page
Contents	✓	—	—	—	<a href="#">p. 5-17</a>
Equipment number	✓	—	—	1 –	<a href="#">p. 5-17</a>
Equipment name	✓	✓	—	Each unit's model No. (Example: AN-8000EX)	SW: <a href="#">p. 5-17</a> BR: <a href="#">p. 6-5</a>
Station number digit	✓	—	—	2	<a href="#">p. 5-20</a>
Station number	✓	—	✓*	Line 1: 10, Line 2: 11, ..., , Line 16: 25	SW: <a href="#">p. 5-20</a> BR: <a href="#">p. 7-6</a>
Station name	✓	—	—	—	<a href="#">p. 5-20</a>
Network communications ON or OFF between exchanges	✓	—	—	—	<a href="#">p. 5-22</a>
Multicast communications ON or OFF between exchanges	✓	—	—	—	<a href="#">p. 5-23</a>

\* Settings can only be performed from the AN-8000MS Multifunctional Master station and AN-8500MS IP Multifunctional Master station.



## 1.2. Exchange

### 1.2.1. Network settings

Item	Setting from Software	Setting from browser	Setting from station	Default	Reference page
IP address* <sup>1</sup>	✓	✓	✓ * <sup>2</sup>	192.168.1.1	SW: <a href="#">p. 5-12/17/24</a> BR: <a href="#">p. 6-5</a> ST: <a href="#">p. 7-5</a>
Subnet Mask* <sup>1</sup>	✓	✓	✓ * <sup>2</sup>	255.255.255.0	SW: <a href="#">p. 5-12/13/24</a> BR: <a href="#">p. 6-5</a> ST: <a href="#">p. 7-5</a>
Default Gateway* <sup>1</sup>	✓	✓	✓ * <sup>2</sup>	0.0.0.0	SW: <a href="#">p. 5-12/13/24</a> BR: <a href="#">p. 6-5</a> ST: <a href="#">p. 7-5</a>
Web server port number	✓	✓	—	80	SW: <a href="#">p. 5-12/17/24</a> BR: <a href="#">p. 6-5</a>
TCP start port number	✓	—	—	5000	<a href="#">p. 5-24</a>
UDP start port number	✓	—	—	5006	<a href="#">p. 5-24</a>
Multicast port number	✓	—	—	6000	<a href="#">p. 5-24</a>
NAPT compatible	✓	—	—	Incompatible	<a href="#">p. 5-24</a>
Network ID	✓	—	—	1	<a href="#">p. 5-24</a>
WAN IP address	✓	—	—	192.168.1.1	<a href="#">p. 5-17/24</a>
WAN Web server port number	✓	—	—	80	<a href="#">p. 5-17/24</a>
WAN TCP start port number	✓	—	—	5000	<a href="#">p. 5-24</a>
WAN UDP start port number	✓	—	—	5006	<a href="#">p. 5-24</a>
Broadcast specification	✓	—	—	High quality sound transmission mode	<a href="#">p. 5-24</a>
Communication capacity	✓	—	—	2990 kbps	<a href="#">p. 5-24</a>

\*<sup>1</sup> Be sure to set this since settings and conversations are performed via a network.

\*<sup>2</sup> Settings can only be performed from the AN-8000MS Multifunctional Master station.

### 1.2.2. Sampling frequency correction

Item	Setting from Software	Setting from browser	Setting from station	Default	Reference page
Sampling frequency correction	✓	—	—	Automatic	<a href="#">p. 5-28</a>
Transmitted party IP address	✓	—	—	—	<a href="#">p. 5-28</a>
Transmitted party port number	✓	—	—	—	<a href="#">p. 5-28</a>
Recipient party IP address	✓	—	—	—	<a href="#">p. 5-28</a>
Reception multicast ON/OFF	✓	—	—	—	<a href="#">p. 5-28</a>
Reception multicast address	✓	—	—	—	<a href="#">p. 5-28</a>

**1.2.3. Function settings**

Item	Setting from Software	Setting from browser	Setting from station	Default	Reference page
Call forwarding function	✓	—	—	OFF	<a href="#">p. 5-29</a>
Time-based call forwarding function	✓	—	—	OFF	<a href="#">p. 5-29</a>
Time-based call forwarding start time	✓	—	—	00:00	<a href="#">p. 5-29</a>
Time-based call forwarding end time	✓	—	—	00:00	<a href="#">p. 5-29</a>
Group hunting function	✓	—	—	OFF	<a href="#">p. 5-29</a>
Absence transfer function	✓	—	—	OFF	<a href="#">p. 5-29</a>
Absence transfer call duration	✓	—	—	10 seconds	<a href="#">p. 5-29</a>
Oneshot make time	✓	—	—	1 second	<a href="#">p. 5-29</a>
Call time-out	✓	—	—	No limit	<a href="#">p. 5-29</a>
Conversation time-out	✓	—	—	No limit	<a href="#">p. 5-29</a>
Paging time-out	✓	—	—	No limit	<a href="#">p. 5-29</a>
Paging response mode	✓	—	—	Zone number designation response mode	<a href="#">p. 5-29</a>
Paging priority mode	✓	—	—	Paging priority	<a href="#">p. 5-29</a>
Calling station indication	✓	—	—	Call activated	<a href="#">p. 5-29</a>
BGM input	✓	—	—	—	<a href="#">p. 5-29</a>

## 1.3. Multi Interface Unit

### 1.3.1. Network settings

Item	Setting from Software	Setting from browser	Setting from station	Default	Reference page
IP address*	✓	✓	—	192.168.1.1	SW: p. 5-12/17/31 BR: p. 6-5
Subnet Mask*	✓	✓	—	255.255.255.0	SW: p. 5-12/13/31 BR: p. 6-5
Default Gateway*	✓	✓	—	0.0.0.0	SW: p. 5-12/13/31 BR: p. 6-5
Web server port number	✓	✓	—	80	SW: p. 5-12/17/31 BR: p. 6-5
TCP start port number	✓	—	—	5000	p. 5-31
UDP start port number	✓	—	—	5006	p. 5-31
Multicast port number	✓	—	—	6000	p. 5-31
NAPT compatible	✓	—	—	Incompatible	p. 5-31
Network ID	✓	—	—	1	p. 5-31
WAN IP address	✓	—	—	192.168.1.1	p. 5-17/31
WAN Web server port number	✓	—	—	80	p. 5-17/31
WAN TCP start port number	✓	—	—	5000	p. 5-31
WAN UDP start port number	✓	—	—	5006	p. 5-31
Broadcast specification	✓	—	—	High quality sound transmission mode	p. 5-31
Communication capacity	✓	—	—	2990 kbps	p. 5-31

\* Be sure to set this since settings and conversations are performed via a network.

### 1.3.2. Sampling frequency correction

Item	Setting from Software	Setting from browser	Setting from station	Default	Reference page
Sampling frequency correction	✓	—	—	Automatic	p. 5-35
Transmitted party IP address	✓	—	—	—	p. 5-35
Transmitted party port number	✓	—	—	—	p. 5-35
Recipient party IP address	✓	—	—	—	p. 5-35
Reception via multicast ON/OFF	✓	—	—	—	p. 5-35
Reception multicast address	✓	—	—	—	p. 5-35

### 1.3.3. Function settings

Item	Setting from Software	Setting from browser	Setting from station	Default	Reference page
Oneshot make time	✓	—	—	1 second	p. 5-36
Call time-out	✓	—	—	No limit	p. 5-36
Conversation time-out	✓	—	—	No limit	p. 5-36
Paging time-out	✓	—	—	No limit	p. 5-36
Paging response mode	✓	—	—	Zone number designation response mode	p. 5-36
Paging priority mode	✓	—	—	Paging priority	p. 5-36

**1.3.4. Audio I/O**

Item	Setting from Software	Setting from browser	Setting from station	Default	Reference page
Input mode	✓	—	—	Unused	<a href="#">p. 5-38</a>
Input sensitivity	✓	—	—	—	<a href="#">p. 5-38</a>
Tie-line access number	✓	—	—	—	<a href="#">p. 5-38</a>
Analog E&M interface access number	✓	—	—	—	<a href="#">p. 5-38</a>
Paging zone	✓	—	—	—	<a href="#">p. 5-38</a>
Line attribute	✓	—	—	—	<a href="#">p. 5-38</a>
Line start	✓	—	—	—	<a href="#">p. 5-38</a>
Output mode	✓	—	—	Unused	<a href="#">p. 5-38</a>
Output level	✓	—	—	—	<a href="#">p. 5-38</a>

**1.3.5. Contact I/O**

Item	Setting from Software	Setting from browser	Setting from station	Default	Reference page
Contact input mode	✓	—	—	Unused	<a href="#">p. 5-40</a>
Interlock contact	✓	—	—	—	<a href="#">p. 5-40</a>
Paging zone for Aux input paging	✓	—	—	—	<a href="#">p. 5-40</a>
Access number digit for external equipment control	✓	—	—	2	<a href="#">p. 5-40</a>
Access number	✓	—	—	—	<a href="#">p. 5-40</a>

## 1.4. IP Stations

### 1.4.1. Network settings

Item	Setting from Software	Setting from browser	Setting from station	Default	Reference page
IP address* <sup>1</sup>	✓	✓	✓* <sup>2</sup>	192.168.1.1	SW: p. 5-12/17/42 BR: p. 6-5
Subnet Mask* <sup>1</sup>	✓	✓	✓* <sup>2</sup>	255.255.255.0	SW: p. 5-12/13/42 BR: p. 6-5
Default Gateway* <sup>1</sup>	✓	✓	✓* <sup>2</sup>	0.0.0.0	SW: p. 5-12/13/42 BR: p. 6-5
Web server port number	✓	✓	—	80	SW: p. 5-12/17/42 BR: p. 6-5
TCP start port number	✓	—	—	5000	p. 5-42
UDP start port number	✓	—	—	5006	p. 5-42
Multicast port number	✓	—	—	6000	p. 5-42
NAPT compatible	✓	—	—	Incompatible	p. 5-42
Network ID	✓	—	—	1	p. 5-42
WAN IP address	✓	—	—	192.168.1.1	p. 5-17/42
WAN Web server port number	✓	—	—	80	p. 5-17/42
WAN TCP start port number	✓	—	—	5000	p. 5-42
WAN UDP start port number	✓	—	—	5006	p. 5-42
Broadcast specification	✓	—	—	High quality sound transmission mode	p. 5-42
Communication capacity	✓	—	—	2990 kbps	p. 5-42

\*<sup>1</sup> Be sure to set this since settings and conversations are performed via a network.

\*<sup>2</sup> Settings can only be performed from the AN-8500MS IP Multifunctional Master station.

### 1.4.2. Function settings 1

Item	Setting from Software	Setting from browser	Setting from station	Default	Reference page
Call forwarding function* <sup>3</sup>	✓	—	—	OFF	p. 5-46
Time-based call forwarding function* <sup>3</sup>	✓	—	—	OFF	p. 5-46
Time-based call forwarding start time* <sup>3</sup>	✓	—	—	00:00	p. 5-46
Time-based call forwarding end time* <sup>3</sup>	✓	—	—	00:00	p. 5-46
Group hunting function* <sup>3</sup>	✓	—	—	OFF	p. 5-46
Absence transfer function* <sup>3</sup>	✓	—	—	OFF	p. 5-46
Absence transfer call duration* <sup>3</sup>	✓	—	—	10 seconds	p. 5-46
Oneshot make time	✓	—	—	1 second	p. 5-46
Call time-out	✓	—	—	No limit	p. 5-46
Conversation time-out	✓	—	—	No limit	p. 5-46
Paging time-out* <sup>3</sup>	✓	—	—	No limit	p. 5-46
Paging response mode* <sup>3</sup>	✓	—	—	Zone number designation response mode	p. 5-46
Paging priority mode	✓	—	—	Paging priority	p. 5-46
Calling station indication	✓	—	—	Call activated	p. 5-46
BGM input	✓	—	—	—	p. 5-46

\*<sup>3</sup> Settings can be performed only to the AN-8500MS IP Multifunctional Master Station.

## 1.4.3. Function settings 2

Item	Setting from Software	Setting from browser	Setting from station	Default	Reference page
Incoming call mode* <sup>1</sup>	✓	—	—	Automatic connection mode	<a href="#">p. 5-48</a>
Automatic connection call tone	✓	—	—	With a call tone	<a href="#">p. 5-48</a>
Continuous call tone* <sup>1</sup>	✓	—	—	With a call tone	<a href="#">p. 5-48</a>
Microphone sensitivity	✓	—	—	Level 2	<a href="#">p. 5-48</a>
Speaker output	✓	—	✓ * <sup>2</sup>	Level 3	SW: <a href="#">p. 5-48</a> ST: <a href="#">p. 2-4</a>
Station speaker sound volume	✓	—	—	Level 3	<a href="#">p. 5-48</a>
Group call member* <sup>1</sup>	✓	—	—	—	<a href="#">p. 5-48</a>
Call forwarding destination station* <sup>1</sup>	✓	—	✓ * <sup>2</sup>	—	SW: <a href="#">p. 5-48</a> ST: <a href="#">p. 2-17</a>
Time-based call forwarding destination station* <sup>1</sup>	✓	—	✓ * <sup>2</sup>	—	SW: <a href="#">p. 5-48</a> ST: <a href="#">p. 2-18</a>
Absence transfer destination station* <sup>1</sup>	✓	—	✓ * <sup>2</sup>	—	SW: <a href="#">p. 5-48</a> ST: <a href="#">p. 2-16</a>
Group hunting destination station* <sup>1</sup>	✓	—	✓ * <sup>2</sup>	—	SW: <a href="#">p. 5-48</a> ST: <a href="#">p. 2-15</a>
BGM reception ON/OFF	✓	—	—	OFF	<a href="#">p. 5-48</a>
BGM input	✓	—	✓ * <sup>2</sup>	—	SW: <a href="#">p. 5-48</a> ST: <a href="#">p. 2-32</a>
Door station mode	✓	—	—	Unavailable	<a href="#">p. 5-48</a>
Access to priority call* <sup>1</sup>	✓	—	—	Unavailable	<a href="#">p. 5-48</a>
Refusal of priority call setting	✓	—	—	Allowed to accept	<a href="#">p. 5-48</a>
Access to paging call* <sup>1</sup>	✓	—	—	Available	<a href="#">p. 5-48</a>
External equipment control ON/OFF* <sup>1</sup>	✓	—	—	OFF	<a href="#">p. 5-48</a>
Door remote contact output number	✓	—	—	—	<a href="#">p. 5-48</a>
Calling station indication/CCTV contact output number	—	—	✓ * <sup>2</sup>	—	<a href="#">p. 5-48</a>
Calling station indication/CCTV called station's number	✓	—	—	—	<a href="#">p. 5-48</a>

\*<sup>1</sup> Settings can be performed only to the AN-8500MS IP Multifunctional Master Station.

\*<sup>2</sup> Settings can only be performed from the AN-8500MS IP Multifunctional Master station.

## 1.4.4. Speed dialing

Item	Setting from Software	Setting from browser	Setting from station	Default	Reference page
Onetouch dial	✓	—	✓ * <sup>3</sup>	—	SW: <a href="#">p. 5-50</a> ST: <a href="#">p. 2-10</a>
Master calling	✓	—	—	—	<a href="#">p. 5-50</a>
Auto dial	—	—	✓ * <sup>3</sup>	—	<a href="#">p. 2-9</a>

\*<sup>3</sup> Settings can only be performed from the AN-8000MS Multifunctional Master station.

### 1.4.5. Scan monitor

Item	Setting from Software	Setting from browser	Setting from station	Default	Reference page
Scan monitor group	✓	—	—	—	<a href="#">p. 5-51</a>
Scan monitor sequencing time	✓	—	—	3 seconds	<a href="#">p. 5-51</a>

## 1.5. Stations

### 1.5.1. Function settings

Item	Setting from Software	Setting from browser	Setting from station	Default	Reference page
Incoming call mode	✓	—	—	Automatic connection mode	<a href="#">p. 5-52</a>
Automatic connection call tone	✓	—	—	With a call tone	<a href="#">p. 5-52</a>
Continuous call tone	✓	—	—	With a call tone	<a href="#">p. 5-52</a>
Microphone sensitivity	✓	—	—	Level 2	<a href="#">p. 5-52</a>
Speaker output	✓	—	✓ *	Level 3	SW: <a href="#">p. 5-52</a> ST: <a href="#">p. 2-4</a>
Station speaker sound volume	✓	—	—	Level 3	<a href="#">p. 5-52</a>
Group call member	✓	—	—	—	<a href="#">p. 5-52</a>
Call forwarding destination station	✓	—	✓ *	—	SW: <a href="#">p. 5-52</a> ST: <a href="#">p. 2-17</a>
Time-based call forwarding destination station	✓	—	✓ *	—	SW: <a href="#">p. 5-52</a> ST: <a href="#">p. 2-18</a>
Absence transfer destination station	✓	—	✓ *	—	SW: <a href="#">p. 5-52</a> ST: <a href="#">p. 2-16</a>
Group hunting destination station	✓	—	✓ *	—	SW: <a href="#">p. 5-52</a> ST: <a href="#">p. 2-15</a>
BGM reception ON/OFF	✓	—	—	OFF	<a href="#">p. 5-52</a>
BGM input	✓	—	✓ *	—	SW: <a href="#">p. 5-52</a> ST: <a href="#">p. 2-32</a>
Door station mode	✓	—	—	Unavailable	<a href="#">p. 5-52</a>
Access to priority call	✓	—	—	Unavailable	<a href="#">p. 5-52</a>
Refusal of priority call setting	✓	—	—	Allowed to accept	<a href="#">p. 5-52</a>
Access to paging call	✓	—	—	Available	<a href="#">p. 5-52</a>
External equipment control ON/OFF	✓	—	—	OFF	<a href="#">p. 5-52</a>
Door remote contact output number	✓	—	—	—	<a href="#">p. 5-52</a>
Calling station indication/CCTV contact output number	✓	—	—	—	<a href="#">p. 5-52</a>
Calling station indication/CCTV called station's number	✓	—	—	—	<a href="#">p. 5-52</a>

\* Settings can be performed from all master stations.

**1.5.2. Speed dialing**

Item	Setting from Software	Setting from browser	Setting from station	Default	Reference page
Onetouch dial	✓	—	✓ *1	—	SW: <a href="#">p. 5-55</a> ST: <a href="#">p. 2-10</a>
Master calling	✓	—	—	—	<a href="#">p. 5-55</a>
Auto dial	—	—	✓ *2	—	<a href="#">p. 2-9</a>

\*1 Settings can be performed from all master stations.

\*2 Settings can only be performed from the AN-8000MS Multifunctional Master station.

**1.5.3. Scan monitor**

Item	Setting from Software	Setting from browser	Setting from station	Default	Reference page
Scan monitor group	✓	—	—	—	<a href="#">p. 5-56</a>
Scan monitor sequencing time	✓	—	—	3 seconds	<a href="#">p. 5-56</a>

**1.5.4. Paging**

Item	Setting from Software	Setting from browser	Setting from station	Default	Reference page
Paging number digit	✓	—	—	—	<a href="#">p. 5-57</a>
Paging port start number	✓	—	—	—	<a href="#">p. 5-57</a>
Paging zone name	✓	—	—	—	<a href="#">p. 5-57</a>
Paging zone setting	✓	—	—	—	<a href="#">p. 5-57</a>

**1.5.5. Group**

Item	Setting from Software	Setting from browser	Setting from station	Default	Reference page
Group blocking group	✓	—	—	—	<a href="#">p. 5-58</a>
Group blocking destination	✓	—	—	—	<a href="#">p. 5-59</a>
Remote response group	✓	—	—	—	<a href="#">p. 5-60</a>



## 2. TURNING THE SYSTEM'S POWER SWITCH ON

To perform system settings, the power supply needs to be connected to the system.

### 2.1. Caution When Turning the Power Switch On

Check the following to be sure before turning the power switch on:

Cables and connectors are correctly wired and connected.

The functional earth of Exchanges and Multi interface units is correctly grounded.

### 2.2. Turning the Power Switch On

Follow the procedures below to turn the power switch on.

**Step 1.** Turn the power switches on of the network equipment connected such as switching hubs, router, etc on.

**Step 2.** Turn all exchanges', multi interface units' and IP stations' power switches on.

## 3. SETTING PROCEDURES

**1. Set a network.** (Refer to [p. 5-9, 6-5, 7-5](#))

Perform network settings (IP address, Default gateway, and Subnet mask) for all exchanges, Multi interface units and IP stations connected to the local network. For network settings, refer to "Network Settings Using a Personal Computer " described on the next page.

**2. Perform system settings.** (Refer to [p. 5-15](#))

Use the supplied AN-8000 Software program to perform individual settings related to the system such as the Exchange, Multi interface unit, Station, Paging, etc.

**3. Save the settings and upload to the units.** (Refer to [p. 5-62](#))

Save the setting contents and write them into the Exchange, Multi interface unit, and IP stations.

## 4. NETWORK SETTINGS USING A PERSONAL COMPUTER

This section uses a system example in which three local area networks (LAN) are connected via the Internet in order to explain how to perform network settings for each exchange, multi interface unit, and IP station using a PC.

This example assumes that broadcast communications are possible within each LAN, but not possible between different LANs. The PC (A) connected to LAN (A) is assumed to be used for system settings.

### [System example]

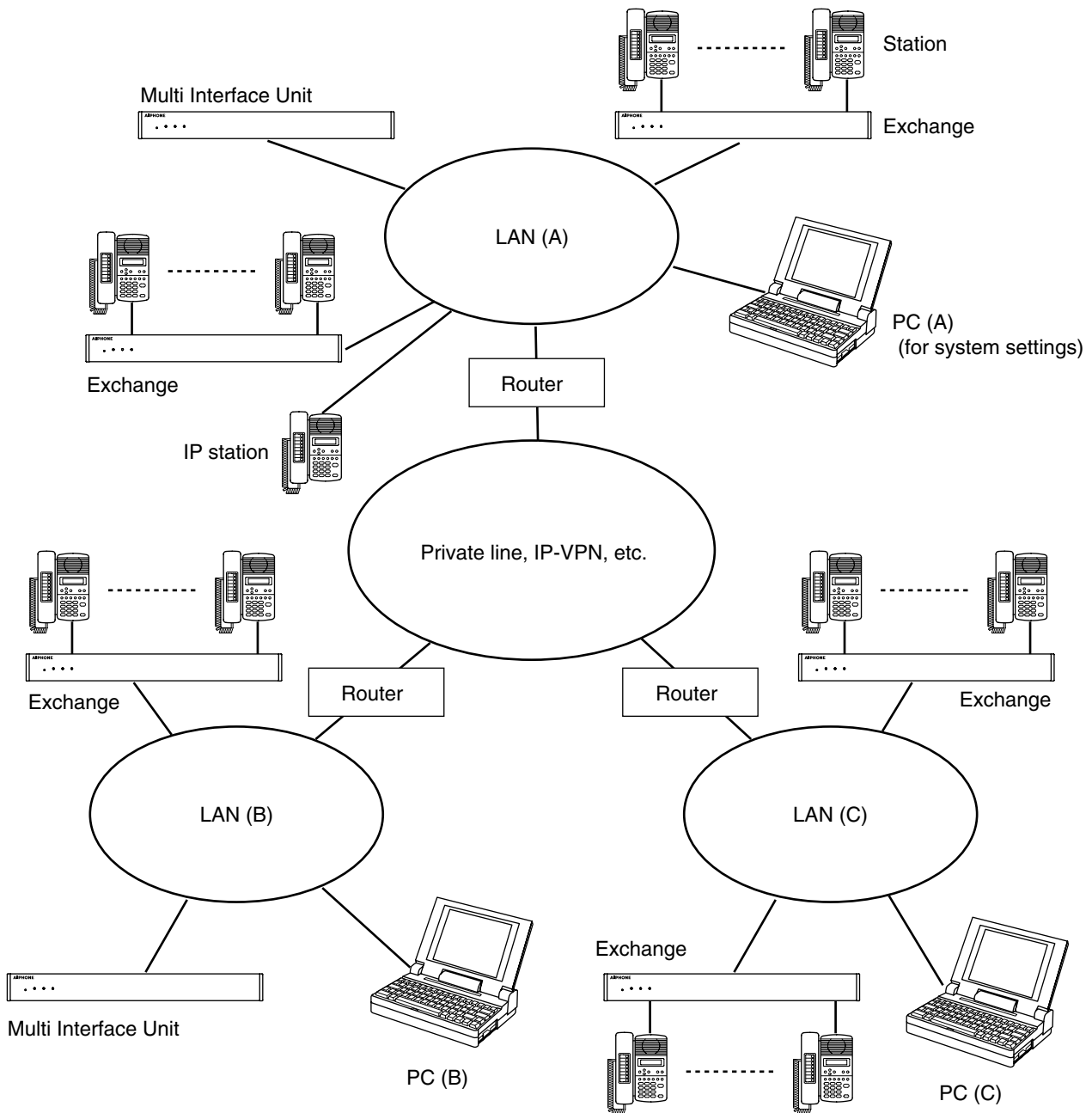

**[Setting procedures]**

**Step 1.** Using a system setting PC\*<sup>1</sup>, set a network\*<sup>2</sup> for Exchanges, Multi interface units, and IP stations that permit broadcast communications with this PC.

\*<sup>1</sup> PC (A) in the illustration on the previous page

\*<sup>2</sup> LAN (A) in the illustration on the previous page

Use the supplied AN-8000 software program's unit scan function to perform settings. (Refer to [p. 5-9.](#))

**Step 2.** Using the PC in each LAN, set the networks\*<sup>3</sup> for Exchanges, Multi interface units, and IP stations that cannot conduct broadcast communications with the system setting PC.

\*<sup>3</sup> LANs (B) and (C) in the illustration on the previous page.

- Use the AN-8000 software program's unit scan function to perform settings.

**Note**

Use the AN-8000 software only for the network settings of Exchanges, Multi interface units, and IP stations. When performing individual settings related to the general system, use the PC (A).

- One of the following two methods can also be used to perform settings (Refer to [p. 6-5.](#)):

(1) Perform settings via a network using the PC's Web browser.

**Note**

If the system contains multiple Exchanges, Multi interface units, or IP stations, and their IP address numbers are identical (factory-preset setting), connect each exchange to a network and perform settings individually.

(2) Disconnect the Exchange, Multi interface units, or IP stations from the LAN to directly connect it to the PC using a crossover LAN cable, then perform settings by way of the Web browser.

- Another method can also be used to perform settings on the menu screen of the multifunctional master station without using a PC. To perform an exchange's network setting, connect the multifunctional master station to the exchange to be set. For the IP multifunctional master station, its network setting can be performed using its on-screen setting menu. (Refer to [p. 7-5.](#))

**Step 3.** Set the system to allow communications from the system setting PC to all Exchanges, Multi interface units, and IP stations on the network.

Using the AN-8000 software's system setting function on the system setting PC, register the Exchanges, Multi interface units, and IP stations of which network settings have been set in **Step 1** or **2**.

(Refer to [p. 5-17.](#))

These procedures permit communications between the system setting PC and all Exchanges, Multi interface units, and IP stations within the system.

# ***Chapter 5***

---

## ***SYSTEM SETTINGS BY SOFTWARE***

This chapter describes how to install and use the AN-8000 system settings software.

# 1. AN-8000 SOFTWARE GENERAL DESCRIPTION

## 1.1. General Description

The supplied AN-8000 software program is for performing system settings and features following two functions.

### 1.1.1. Equipment scan and network setting functions

Detect the Exchange, Multi interface unit, and IP station connected to the local network, and then perform equipment network settings. Use this software when performing initial setting.

#### Note

The equipment scan function can only be used within the effective broadcast range. Other equipment that is not within this range must be set using a different network setting (Refer to [p. 4-12](#)).

### 1.1.2. System setting function

Performs individual settings related to system.

#### Note

This software does not display system operation logs, but these can be viewed using browser software instead. (Refer to [p. 6-17](#).)

## 1.2. PC Network Settings

Perform PC network settings in advance according to your network administrator's instructions. Be sure to verify these, since incorrect settings could adversely affect other equipment connected to the same network.

#### Note

Perform the PC's network setting to allow the PC to communicate with Exchanges, Multi interface units, and IP stations.

AN-8000 system settings cannot be performed unless the PC's network setting is completed.

However, even the PC of which network setting is not completed may perform the network setting for the Exchange, Multi interface unit, and IP station.

## 1.3. Notes on Setting Update

To avoid equipment failures, never restart the Exchange, Multi interface unit, and IP station or switch off the power while in the process of updating\* settings.

\* The Status indicator light will remain lit while updating is in progress.

## 2. INSTALLING SOFTWARE

### 2.1. System Requirements

This program has been designed based on the following system requirements.

- |       |                                  |
|-------|----------------------------------|
| • OS  | : Windows 2000/XP                |
| • CPU | : Pentium III 800 MHz or greater |

#### Note

Windows is the registered trademark of Microsoft Corporation.

Pentium is the registered trademark of Intel Corporation.

### 2.2. Activating the Setup Guide

Placing the supplied CD-ROM into the CD drive runs the setup guide automatically.

#### Note

If your PC's CD drive is not compatible with the AutoRun function, the setup guide is not automatically started even when the CD is inserted.

Use either "Explorer" or "My Computer" to execute the following files, or use [Start → Run] in the Task Bar and enter the following command.

<Drive where CD is placed> \index.html

For example, when placing the CD in the "d" drive, → d:\index.html

The following screen will be displayed.

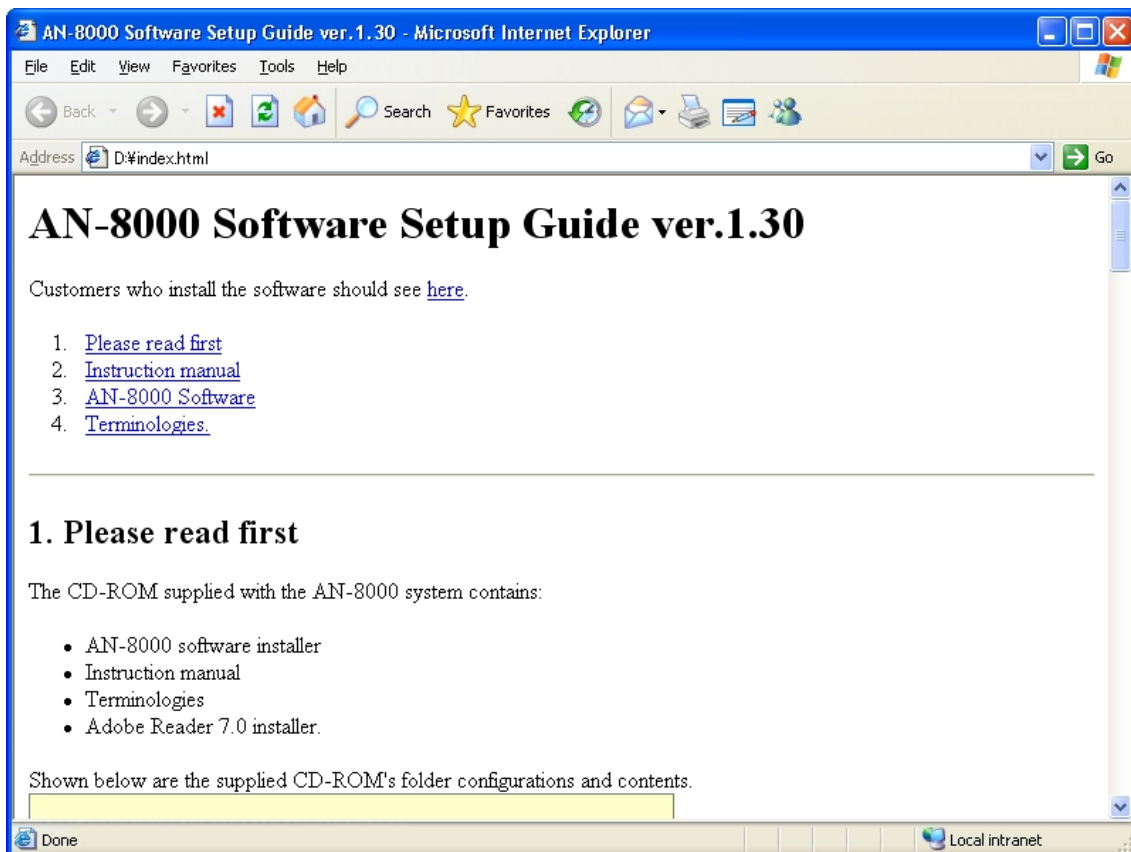

## 2.3. AN-8000 Software Installation

### 2.3.1. Installation

**Step 1.** Click [Installation start] at [AN-8000 Software Installation] in the setup guide causes the installer to activate.

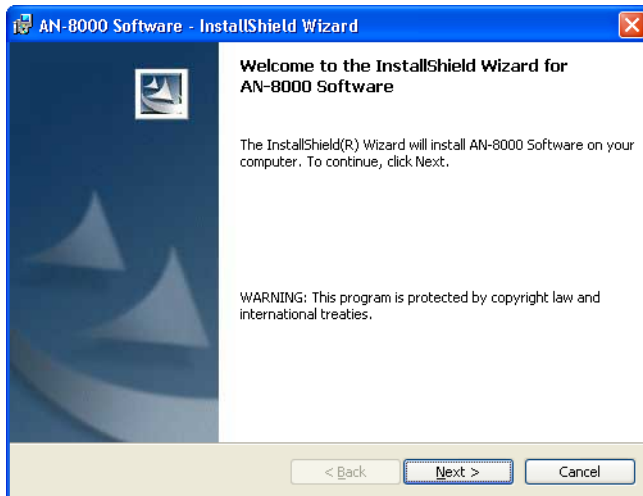

**Step 2.** Press [Next] Button.  
The screen "Destination Folder" will be displayed.

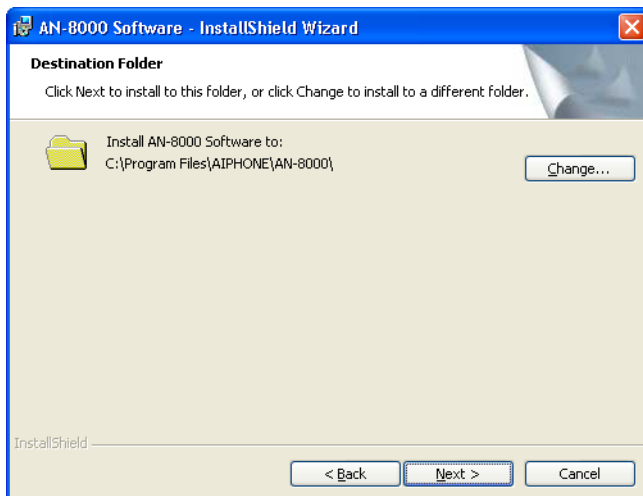

**Step 3.** Select Installation Folder.

To install the software into a different folder other than the folder indicated in Destination Folder, click [Change] button to select a desired folder.

Click [Next] button to install the software into the current folder.

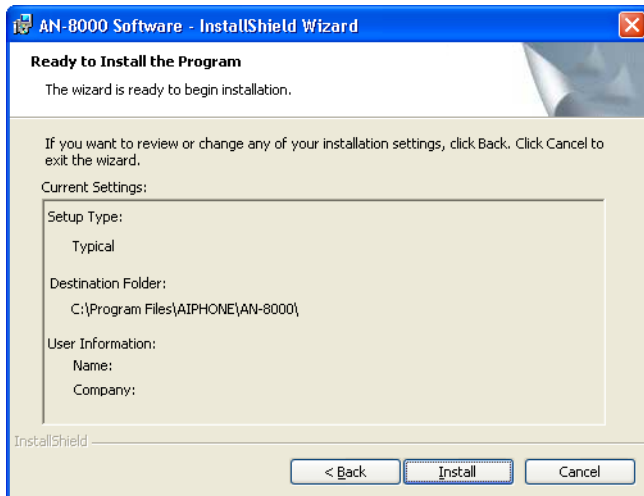
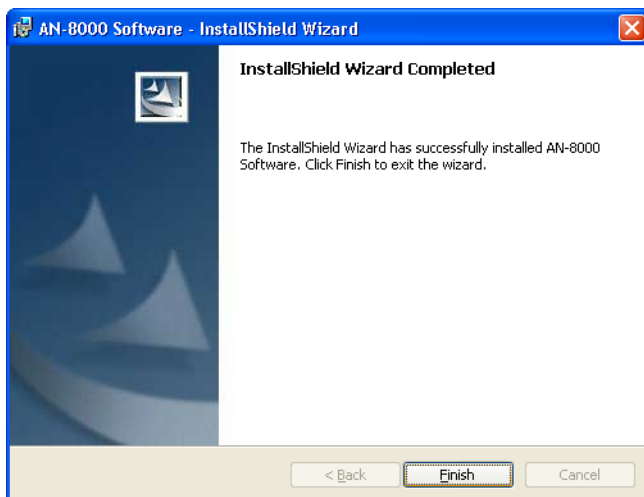
**Step 4.** Press [Install] to install the software program into the selected holder. The setup completion screen can be displayed when the installation is correctly completed.**Step 5.** Press [Finish].**2.3.2. Version update information**

Please contact to the AIPHONE sales office to obtain the up-to-date version for firmware, software and the instruction manuals.

- The software version number can be confirmed using the Help menu.
- The current firmware version can be confirmed on the system management screen displayed when the browser establishes the connection to the Exchange, Multi interface unit, or IP station.
- The instruction manual version number can be confirmed by checking the preparation date (month and year) shown at the lower right corner of the last page.

Example: Prepared in March 2006: 200603



### 2.3.3. Install folder configuration

The AN-8000 software program is installed in the default location C:\Program Files\ AIPHONE\AN-8000. The configuration of the install folder is as follows. (Note the system setting file is created after the setting has been performed using the software.)

Avoid changing the names or locations of the files and folders found within the install folder.

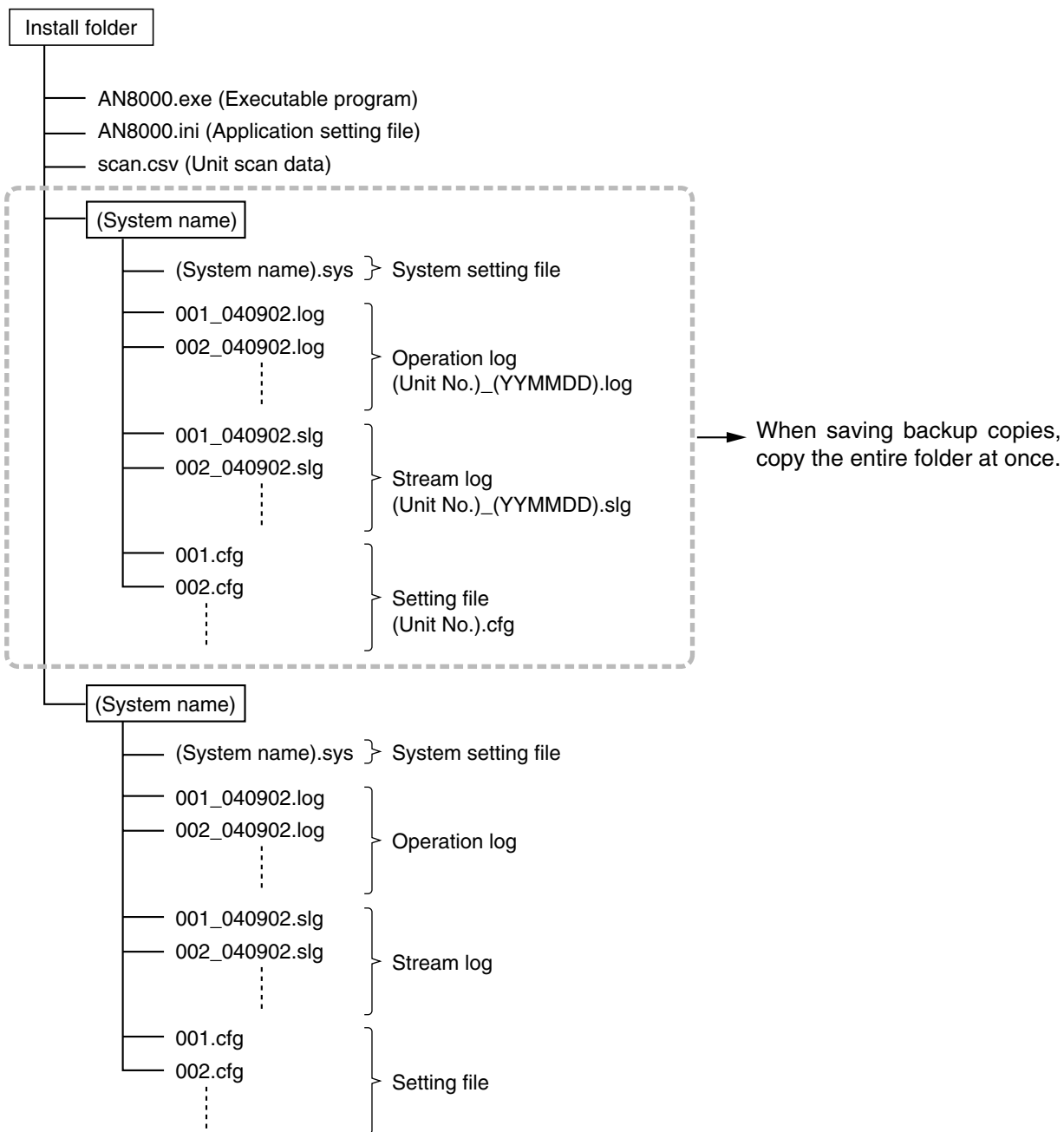

### 2.4. AN-8000 Software Uninstallation

Select [Control Panel] → [Add/Remove Programs] to delete the AN-8000 Software program.

### 3. ACTIVATING AN-8000 SOFTWARE PROGRAM

**Step 1.** Double-click the shortcut icon created on the desk-top screen when installing, or double-click the AN-8000.exe created in the installed folder directly.  
[User Certification] screen is displayed.



**Step 2.** Select "System name", enter password, then press [OK].

**Note**

System name and password are case-sensitive.  
When setting a new system name, select "New system", then press [OK].

System name and password are factory-preset to "AN-8000" and "guest" respectively.  
For changing System name or Password, refer to [p. 5-63](#).

After system name and password have been entered correctly, AN-8000 Software program initial screen is displayed.

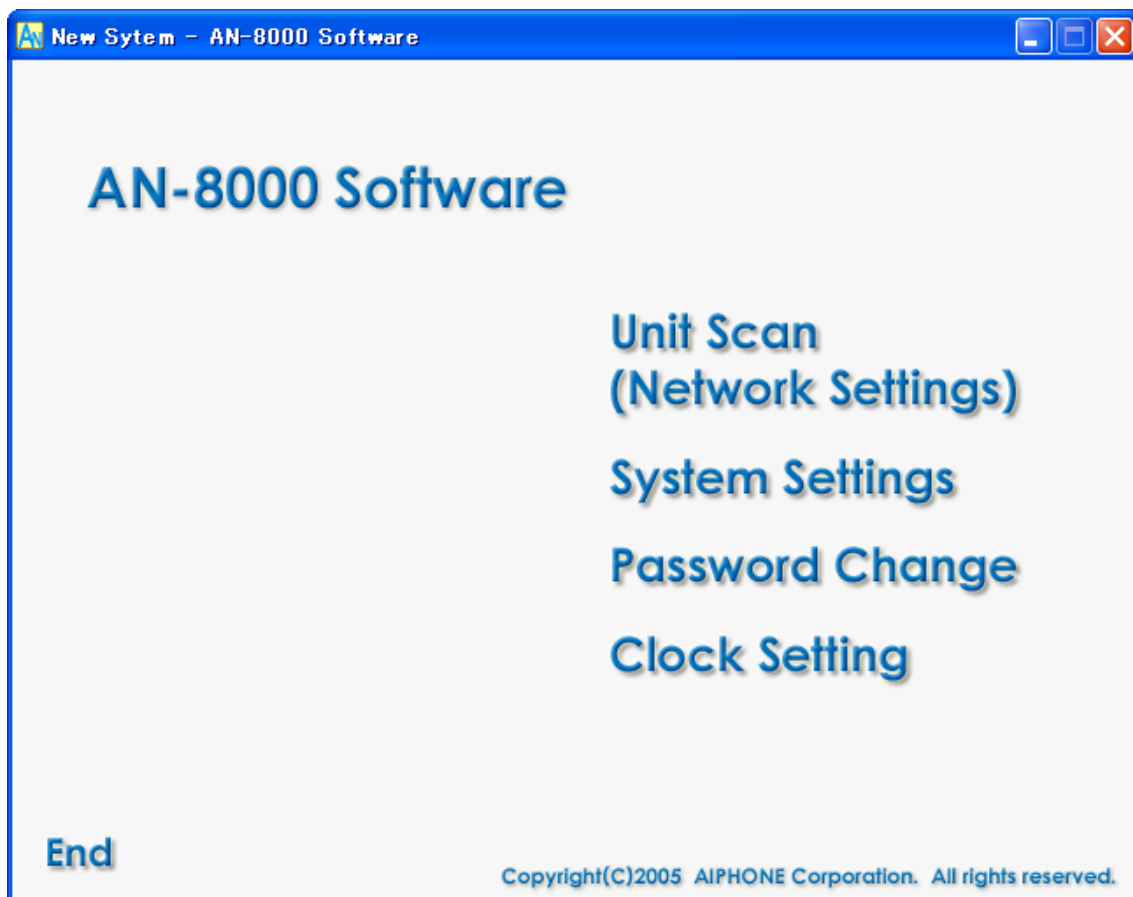

**Step 3.** Click [Unit Scan (Network Settings)] when detecting equipment.

**Step 4.** Click [System Settings] when setting system.

**Step 5.** Click [Password Change] when changing password.

**Step 6.** Click [Clock Setting] when setting system clock.

**Step 7.** Click [End] when terminating this software program.

## 4. UNIT SCAN (NETWORK SETTINGS)

These functions enable the detection and network setting of Exchanges, Multi interface units, and IP stations connected to the local area network.

The equipment detection function can only be used within the effective broadcast range (refer to p. 8-5). Other equipment must be set using a different network setting (refer to p. 4-12).

### 4.1. Screen Description

Click [Unit Scan (Network Settings)] on the initial screen.

The following shows an example of the screen displayed after equipment has been scanned, including a list of scanned Exchanges, Multi interface units, and IP stations.

Select	MAC address	Model	IP address	Subnet mask	Default gateway	Web port	Name
<input checked="" type="checkbox"/>	00-05-F9-FF-80-00	AN8000EX	192.168.1.1	255.255.255.0	0.0.0.0	80	EX 1
<input checked="" type="checkbox"/>	00-05-F9-FF-80-01	AN8000EX	192.168.1.2	255.255.255.0	0.0.0.0	80	EX 2
<input checked="" type="checkbox"/>	00-05-F9-FF-80-02	AN8000EX	192.168.1.3	255.255.255.0	0.0.0.0	80	EX 3
<input checked="" type="checkbox"/>	00-05-F9-FF-80-03	AN8000EX	192.168.1.4	255.255.255.0	0.0.0.0	80	EX 4
<input checked="" type="checkbox"/>	00-05-F9-FF-80-04	AN8000EX	192.168.1.5	255.255.255.0	0.0.0.0	80	EX 5
<input checked="" type="checkbox"/>	00-05-F9-FF-80-05	AN8000EX	192.168.1.6	255.255.255.0	0.0.0.0	80	EX 6
<input checked="" type="checkbox"/>	00-05-F9-FF-80-06	AN8000EX	192.168.1.7	255.255.255.0	0.0.0.0	80	EX 7
<input checked="" type="checkbox"/>	00-05-F9-FF-80-07	AN8000EX	192.168.1.8	255.255.255.0	0.0.0.0	80	EX 8
<input checked="" type="checkbox"/>	00-05-F9-FF-80-08	AN8000EX	192.168.1.9	255.255.255.0	0.0.0.0	80	EX 9
<input checked="" type="checkbox"/>	00-05-F9-FF-80-09	AN8000EX	192.168.1.10	255.255.255.0	0.0.0.0	80	EX 10
<input checked="" type="checkbox"/>	00-05-F9-FF-80-0A	AN8000EX	192.168.1.11	255.255.255.0	0.0.0.0	80	EX 11
<input checked="" type="checkbox"/>	00-05-F9-FF-80-0B	AN8000EX	192.168.1.12	255.255.255.0	0.0.0.0	80	EX 12
<input checked="" type="checkbox"/>	00-05-F9-FF-80-0C	AN8000EX	192.168.1.13	255.255.255.0	0.0.0.0	80	EX 13
<input checked="" type="checkbox"/>	00-05-F9-FF-80-0D	AN8000EX	192.168.1.14	255.255.255.0	0.0.0.0	80	EX 14
<input checked="" type="checkbox"/>	00-05-F9-FF-80-0E	AN8000EX	192.168.1.15	255.255.255.0	0.0.0.0	80	EX 15
<input checked="" type="checkbox"/>	00-05-F9-FF-80-0F	AN8000EX	192.168.1.16	255.255.255.0	0.0.0.0	80	EX 16
<input checked="" type="checkbox"/>	00-05-F9-FF-80-10	AN8000EX	192.168.1.17	255.255.255.0	0.0.0.0	80	EX 17
<input checked="" type="checkbox"/>	00-05-F9-FF-80-11	AN8000EX	192.168.1.18	255.255.255.0	0.0.0.0	80	EX 18
<input checked="" type="checkbox"/>	00-05-F9-FF-80-12	AN8000EX	192.168.1.19	255.255.255.0	0.0.0.0	80	EX 19
<input checked="" type="checkbox"/>	00-05-F9-FF-80-13	AN8000EX	192.168.1.20	255.255.255.0	0.0.0.0	80	EX 20
<input checked="" type="checkbox"/>	00-05-F9-FF-80-14	AN8000EX	192.168.1.21	255.255.255.0	0.0.0.0	80	EX 21
<input checked="" type="checkbox"/>	00-05-F9-FF-80-15	AN8000EX	192.168.1.22	255.255.255.0	0.0.0.0	80	EX 22
<input checked="" type="checkbox"/>	00-05-F9-FF-80-16	AN8000EX	192.168.1.23	255.255.255.0	0.0.0.0	80	EX 23
<input checked="" type="checkbox"/>	00-05-F9-FF-80-17	AN8000EX	192.168.1.24	255.255.255.0	0.0.0.0	80	EX 24
<input checked="" type="checkbox"/>	00-05-F9-FF-80-18	AN8000EX	192.168.1.25	255.255.255.0	0.0.0.0	80	EX 25
<input checked="" type="checkbox"/>	00-05-F9-FF-80-19	AN8000EX	192.168.1.26	255.255.255.0	0.0.0.0	80	EX 26
<input checked="" type="checkbox"/>	00-05-F9-FF-80-1A	AN8000EX	192.168.1.27	255.255.255.0	0.0.0.0	80	EX 27

- |   |   |
|---|---|
| <p><b>(1) Select</b><br/>Marks the checkbox associated with the selected corresponding equipment.</p> <p><b>(2) MAC address</b><br/>Displays the scanned equipment MAC address. This address cannot be changed.</p> <p><b>(3) Model</b><br/>Displays the scanned equipment model number. This model number cannot be changed.</p> <p><b>(4) IP address</b><br/>Displays the scanned equipment IP address.</p> | <p><b>(5) Subnet mask</b><br/>Displays the subnet mask to be set for the scanned equipment.</p> <p><b>(6) Default gateway</b><br/>Displays the default gateway to be set for the scanned equipment.</p> <p><b>(7) Web port</b><br/>Displays the Web server's port number.</p> <p><b>(8) Name</b><br/>Displays the scanned equipment name.</p> |
|---|---|

## 4.2. Menu

### 4.2.1. File

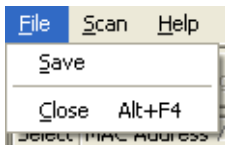

Save : Saves the resultant data of the scanned equipment in "CSV" format.

Close : Terminates this software program.

### 4.2.2. Scan

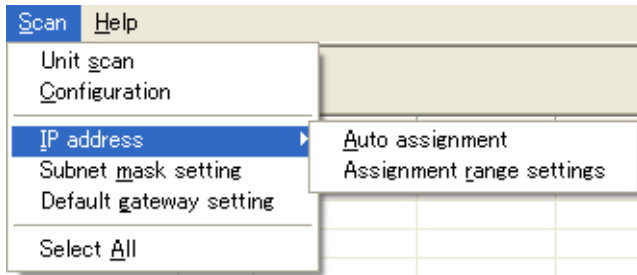

Unit scan : Detects equipment connected to the local area network.

Configuration : Uploads the selected equipment settings.

IP address : Assigns the IP address automatically and performs settings necessary for this assignment.

"Auto assignment" : Assigns an IP address to the selected equipment automatically.

"Assignment range settings" : Sets an IP address range that can be used for automatic IP address assignment.

"Subnet mask setting" : Sets the same subnet mask for the selected equipment.

"Default gateway setting" : Sets the same default gateway for the selected equipment.

"Select All" : Selects all detected equipment.

### 4.2.3. Help



Help : Displays "Help".

About : Displays the Software Program version number.

## 4.3. Buttons

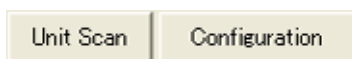

### (1) Unit Scan

Detects equipment connected to the local area network.

### (2) Configuration

Writes an IP address, subnet mask, default gateway, and name to the equipment.

## 4.4. Using Unit Scan

Scan Exchanges, Multi interface units and IP stations connected to the local area network.

### Note

The equipment scan function can only be used within the effective broadcast range.

**Step 1.** Confirm that the system is connected to the network and that power is being supplied to the system. The LNK/ACT indicator on the exchange and multi interface unit, and FD indicator on the IP station will light.

**Step 2.** Press "Unit Scan" button or select "Scan → Unit scan" from the menu bar. This will cause the MAC address, Model number, IP address, Subnet mask, Default gateway, Web port, and Name of the exchange connected to the local area network to be displayed.

### Note

The followings are factory-preset values.

IP address: 192.168.1.1  
 Subnet mask: 255.255.255.0  
 Default gateway: 0.0.0.0  
 Web port: 80  
 Name: AN-8000EX, AN-8000MI, AN-8500MS, or AN-8540DS

The screenshot shows the 'Unit Scanning Tool - AN-8000 Software' window. It has a menu bar with 'File', 'Scan', and 'Help'. Below the menu bar are two tabs: 'Unit Scan' (selected) and 'Configuration'. The main area contains a table with the following columns: 'Select', 'MAC address', 'Model', 'IP address', 'Subnet mask', 'Default gateway', 'Web port', and 'Name'. The table lists 28 units, each with a checkbox in the 'Select' column and a name in the 'Name' column (e.g., EX 1 through EX 27).

Select	MAC address	Model	IP address	Subnet mask	Default gateway	Web port	Name
<input type="checkbox"/>	00-05-F9-FF-80-00	AN8000EX	192.168.1.1	255.255.255.0	0.0.0.0	80	EX 1
<input type="checkbox"/>	00-05-F9-FF-80-01	AN8000EX	192.168.1.2	255.255.255.0	0.0.0.0	80	EX 2
<input type="checkbox"/>	00-05-F9-FF-80-02	AN8000EX	192.168.1.3	255.255.255.0	0.0.0.0	80	EX 3
<input type="checkbox"/>	00-05-F9-FF-80-03	AN8000EX	192.168.1.4	255.255.255.0	0.0.0.0	80	EX 4
<input type="checkbox"/>	00-05-F9-FF-80-04	AN8000EX	192.168.1.5	255.255.255.0	0.0.0.0	80	EX 5
<input type="checkbox"/>	00-05-F9-FF-80-05	AN8000EX	192.168.1.6	255.255.255.0	0.0.0.0	80	EX 6
<input type="checkbox"/>	00-05-F9-FF-80-06	AN8000EX	192.168.1.7	255.255.255.0	0.0.0.0	80	EX 7
<input type="checkbox"/>	00-05-F9-FF-80-07	AN8000EX	192.168.1.8	255.255.255.0	0.0.0.0	80	EX 8
<input type="checkbox"/>	00-05-F9-FF-80-08	AN8000EX	192.168.1.9	255.255.255.0	0.0.0.0	80	EX 9
<input type="checkbox"/>	00-05-F9-FF-80-09	AN8000EX	192.168.1.10	255.255.255.0	0.0.0.0	80	EX 10
<input type="checkbox"/>	00-05-F9-FF-80-CA	AN8000EX	192.168.1.11	255.255.255.0	0.0.0.0	80	EX 11
<input type="checkbox"/>	00-05-F9-FF-80-GB	AN8000EX	192.168.1.12	255.255.255.0	0.0.0.0	80	EX 12
<input type="checkbox"/>	00-05-F9-FF-80-0C	AN8000EX	192.168.1.13	255.255.255.0	0.0.0.0	80	EX 13
<input type="checkbox"/>	00-05-F9-FF-80-0D	AN8000EX	192.168.1.14	255.255.255.0	0.0.0.0	80	EX 14
<input type="checkbox"/>	00-05-F9-FF-80-0E	AN8000EX	192.168.1.15	255.255.255.0	0.0.0.0	80	EX 15
<input type="checkbox"/>	00-05-F9-FF-80-0F	AN8000EX	192.168.1.16	255.255.255.0	0.0.0.0	80	EX 16
<input type="checkbox"/>	00-05-F9-FF-80-10	AN8000EX	192.168.1.17	255.255.255.0	0.0.0.0	80	EX 17
<input type="checkbox"/>	00-05-F9-FF-80-11	AN8000EX	192.168.1.18	255.255.255.0	0.0.0.0	80	EX 18
<input type="checkbox"/>	00-05-F9-FF-80-12	AN8000EX	192.168.1.19	255.255.255.0	0.0.0.0	80	EX 19
<input type="checkbox"/>	00-05-F9-FF-80-13	AN8000EX	192.168.1.20	255.255.255.0	0.0.0.0	80	EX 20
<input type="checkbox"/>	00-05-F9-FF-80-14	AN8000EX	192.168.1.21	255.255.255.0	0.0.0.0	80	EX 21
<input type="checkbox"/>	00-05-F9-FF-80-15	AN8000EX	192.168.1.22	255.255.255.0	0.0.0.0	80	EX 22
<input type="checkbox"/>	00-05-F9-FF-80-16	AN8000EX	192.168.1.23	255.255.255.0	0.0.0.0	80	EX 23
<input type="checkbox"/>	00-05-F9-FF-80-17	AN8000EX	192.168.1.24	255.255.255.0	0.0.0.0	80	EX 24
<input type="checkbox"/>	00-05-F9-FF-80-18	AN8000EX	192.168.1.25	255.255.255.0	0.0.0.0	80	EX 25
<input type="checkbox"/>	00-05-F9-FF-80-19	AN8000EX	192.168.1.26	255.255.255.0	0.0.0.0	80	EX 26
<input type="checkbox"/>	00-05-F9-FF-80-1A	AN8000EX	192.168.1.27	255.255.255.0	0.0.0.0	80	EX 27

## 4.5. Changing Equipment Settings

Change the settings of individual Exchanges, Multi interface units, or IP stations as follows.

**Step 1.** Double-click the desired cell. New data can now be entered in the cell, including IP address, Subnet mask, Default gateway, Web port, and Name.

**Step 2.** Enter the new settings.

**Step 3.** Press [Enter] key or click another cell.

**Step 4.** When you have finished editing the settings, press "Configuration" to write the new settings to the equipment.

### Note

Because the equipment is automatically restarted after new settings have been entered, any conversation or paging in progress at the time is stopped temporarily or terminated.

## 4.6. Automatic IP Address Assignment

Set IP address for the detected Exchange, Multi interface unit, and IP station.

Besides the method referred to above in "Changing Equipment Settings," IP addresses may also be assigned automatically by designating a setting range.

**Step 1.** Mark the checkbox corresponding to the equipment to which the IP address is to be assigned. To assign the address to all equipment, select [Scan] → [Select All] from the menu bar.

**Step 2.** Select [Scan] → [IP address] → [Assignment range settings], then enter a valid IP address range.

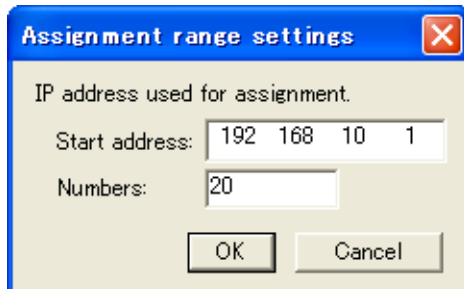

Setting an IP address assignment range makes available the [Scan] → [IP address] → [Auto assignment] option.

**Step 3.** Select [Scan] → [IP address] → [Assignment range settings].  
IP address is assigned automatically without redundant.

**Step 4.** Press "Configuration" to write the new setting to the Equipment.

### Note

Because the equipment is automatically restarted after new settings have been entered, any conversation or paging in progress at the time is stopped temporarily or terminated.

## 4.7. Subnet Mask and Default Gateway Settings

It is possible to set all Exchanges, Multi interface units, and IP stations with the same subnet mask and default gateway.

**Step 1.** Mark the checkbox corresponding to the selected equipment. When selecting all equipment, select [Scan] → [Select All].

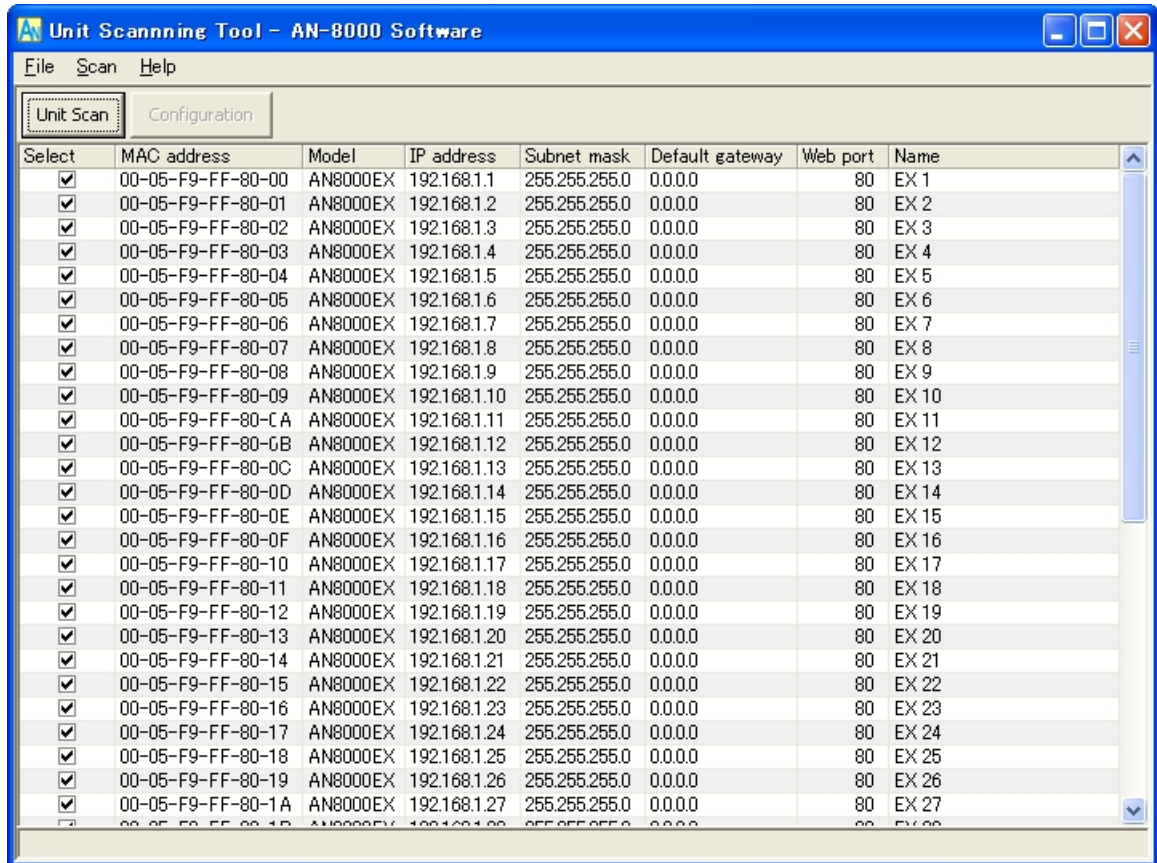

**Step 2.** Set the subnet mask.

2-1. Select [Scan] → [Subnet mask setting].

2-2. When the dialog is displayed, enter the new setting value and click [OK].

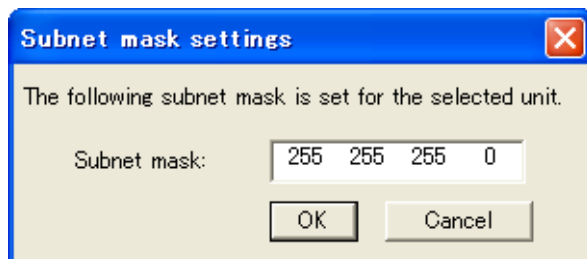



**Step 3.** Set the default gateway.

**3-1.** Select [Scan] → [Default gateway setting].

**3-1.** When the dialog is displayed, enter the new setting value and click [OK].

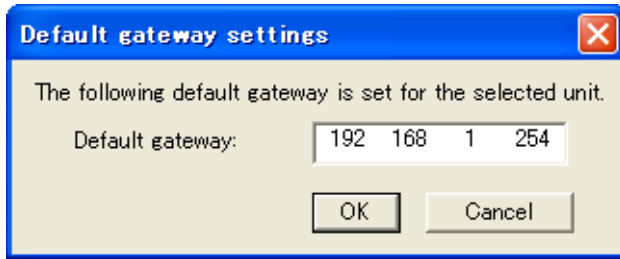

**Step 4.** Press "Configuration" to write the new settings to the equipment.

**Note**

Because the equipment is automatically restarted after new settings have been entered, any conversation or paging in progress at the time is stopped temporarily or terminated.

## 5. SYSTEM SETTING FUNCTION

Performs individual system settings. Use the Unit Scan/Network Setting function, a browser, an AN-8000MS Multifunctional station, or an AN-8500MS IP Multifunctional station to set the IP address correctly, then use this System Setting function to update the exchange's, multi interface unit's, or IP station's setting data.

### 5.1. Screen Description

Click [System Settings] on the initial screen.

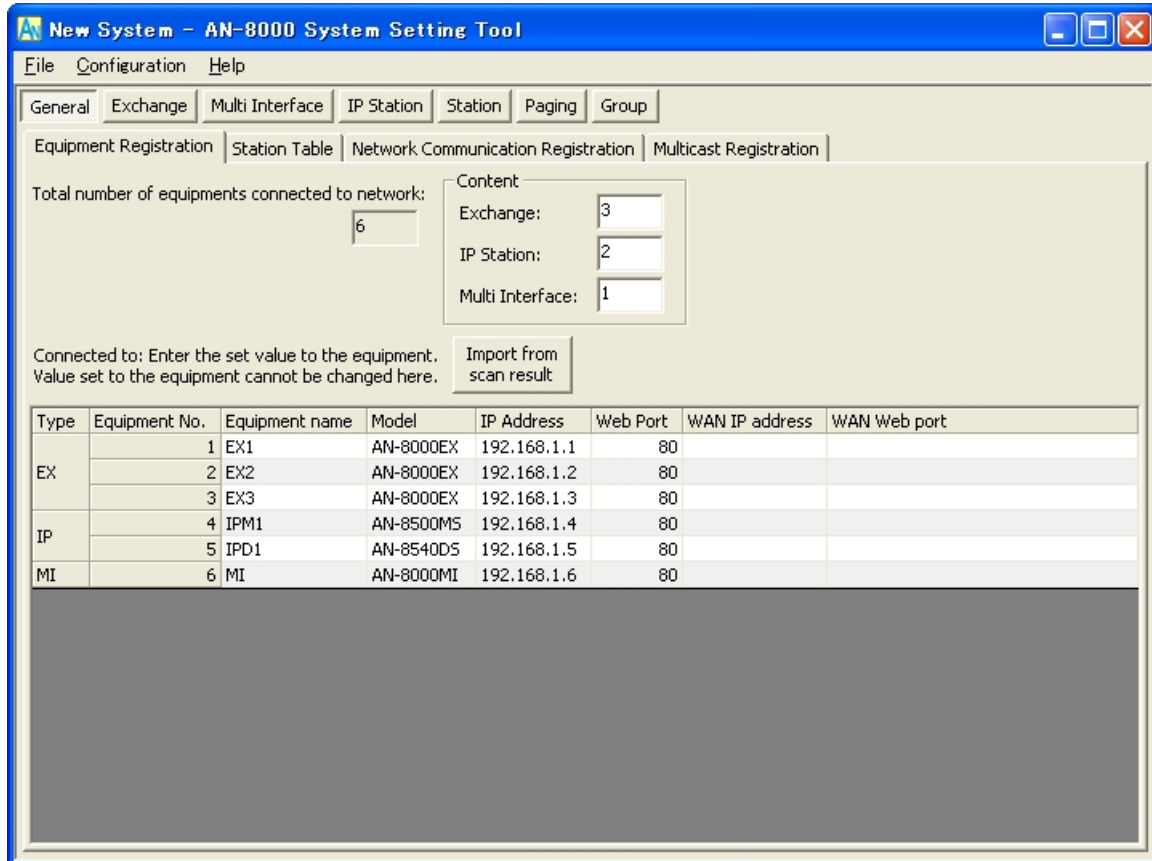

#### Note

The screen above represents the state when settings for 6 pieces of equipment have been completed.

#### (1) General

Performs settings related to the overall system configuration. Available tabs include: [Equipment Registration], [Station Table], [Network Communication Registration] and [Multicast Registration].

#### (2) Exchange

Performs settings related to the exchange. Available tabs include: [Network Setting], [Sampling Frequency Correction] and [Function Settings].

#### (3) Multi Interface

Perform settings related to the multi interface unit. Available tabs include: [Network Setting], [Sampling Frequency Correction], [Function Settings], [Audio I/O] and [Control I/O].

#### (4) IP Station

Performs setting related to the IP station. Available tabs include: [Network Setting], [Function Setting 1], [Function Setting 2], [Speed Dialing] and [Scan Monitor].

#### (5) Station

Performs setting related to the station. Available tabs include: [Function Setting], [Speed Dialing] and [Scan Monitor].

#### (5) Paging

Used to set paging zones.

#### (6) Group

Performs settings for Group Blocking and Remote Response group functions. Available tabs include: [Group blocking group], [Group blocking to] and [Remote response group].

## 5.2. Menu

### 5.2.1. File



New : Creates the setting file for a new system.

Open : Opens the stored setting file.

Save : Saves the setting file currently being edited.

Save As : Saves the setting file being edited as a file for the different system by renaming it.

Close : Terminates this software program.

### 5.2.2. Setting

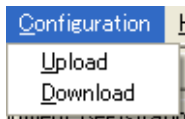

Upload : Writes settings data to equipment.

Download : Downloads equipment settings data to a PC.

### 5.2.3. Help

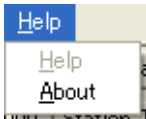

About : Displays the version number of this software program.

### 5.3. Overall System Configuration Settings

Click "General".

#### 5.3.1. Equipment registration

Determines the configuration of the Exchange, Multi interface unit, and IP station within the system and register it. Program data can be entered manually, or it can be imported using data scan for the Equipment using the Unit Scan/Network Setting function.

**Step 1.** Click "Equipment Registration" tab to display the setting screen.

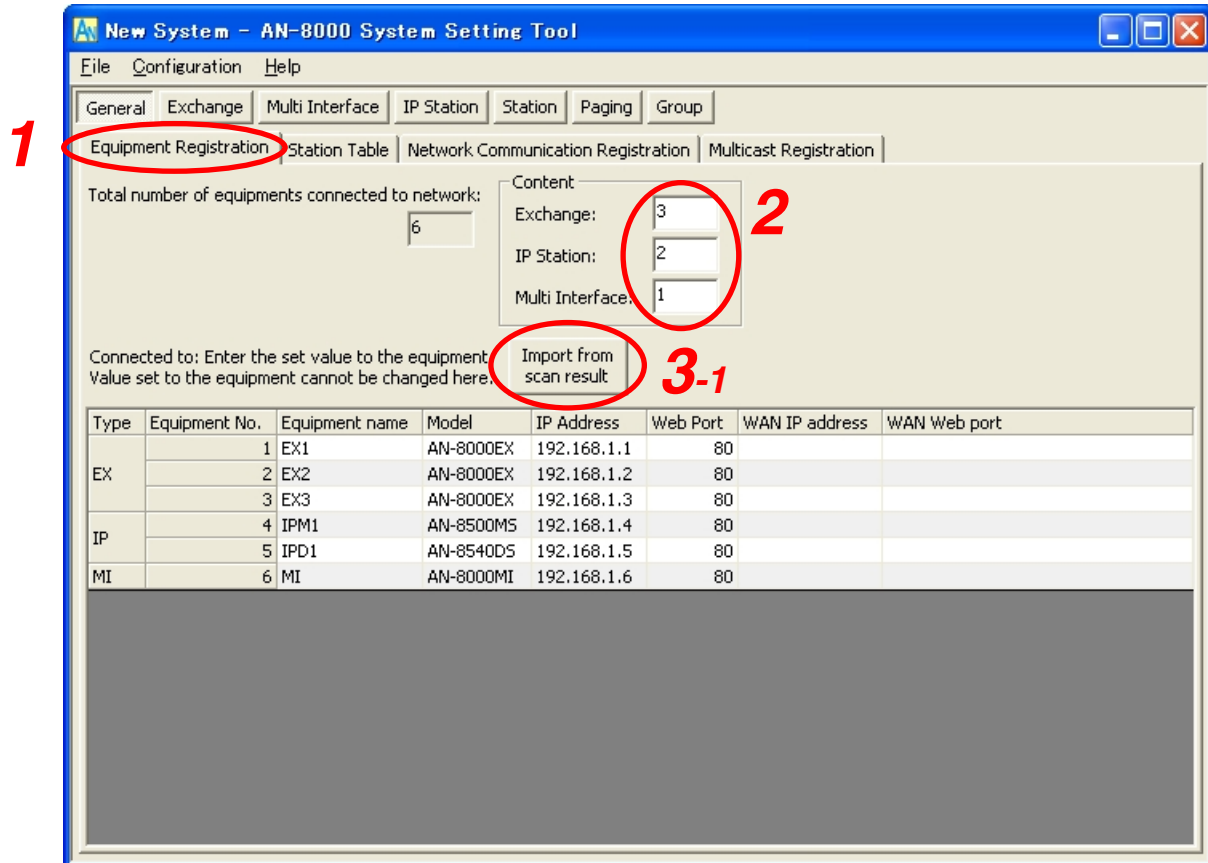

**Note**

The screen above represents the state when settings for 6 pieces of equipment have been completed.

**[Screen description]**

- (1) **Type** (Can't be edited.)  
Indicates the type of equipment entered in **Step 1**.
- (2) **Equipment No.**  
Used to enter the equipment number of the exchange. Default values are assigned in numerical order starting with 1.
- (3) **Equipment name**  
Allows a name up to eight alphanumeric characters to be entered for the equipment.
- (4) **Model**  
Allows the model to be selected. Setting contents change depending on the model selected.  
**Note**  
Selecting the type "EX" indicates model "AN-8000EX," selecting "IP" indicates "AN-8500MS," and selecting "MI" indicates "AN-8000MI."  
To select other equipment, model number needs to be selected. Click a cell to select model.
- (5) **IP Address**  
Allows an IP address for the equipment to be entered.
- (6) **Web Port**  
Allows the Web server's port number to be entered.
- (7) **WAN IP address**  
Allows the IP address for the equipment as viewed from the wide-area network (WAN) to be entered. This space may be left blank if NAPT is not used.
- (8) **WAN Web port**  
Allows the Web server's port number for the equipment as viewed from the wide-area network (WAN) to be entered. This space may be left blank if NAPT is not used.

**Step 2.** Set the system configuration.

Enter the number of Exchanges, Multi interface units, and IP stations.

The total number is displayed in the "Total number of equipment connected to Network" space, and a list of equipment (exchanges, multi interface units, and IP stations) is displayed.

**Step 3.** Set the Equipment name, Model, IP Address, and Web Port.

These items can be set directly by clicking and editing the data in each cell, or by importing equipment data detected using the Unit Scan/Network Setting function. Follow the below procedures when importing data from the result of Unit Scan.

**3-1.** Press [Import from scan result] to display the following dialog.

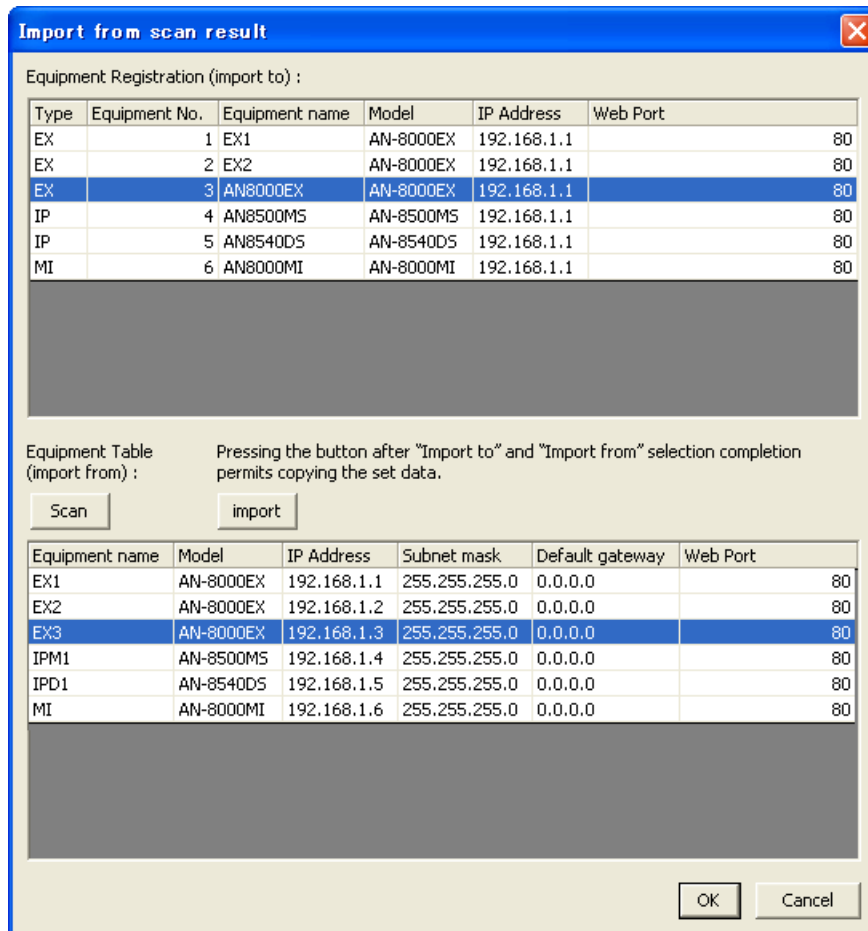

**3-2.** Select an import destination from [Equipment Registration], and select an import source from [Equipment Table], then press the [import] button. This will cause the settings data for the detected equipment to be copied to the equipment selected as the import destination.

**3-3.** Click [OK] to close the dialog and return the display to the previous edit screen.

**Step 4.** Change the WAN IP address and the WAN Web port as required by clicking and editing the contents of each cell directly.

### 5.3.2. Station number and type settings

**Step 1.** Click "Station Table" tab to display the setting screen.

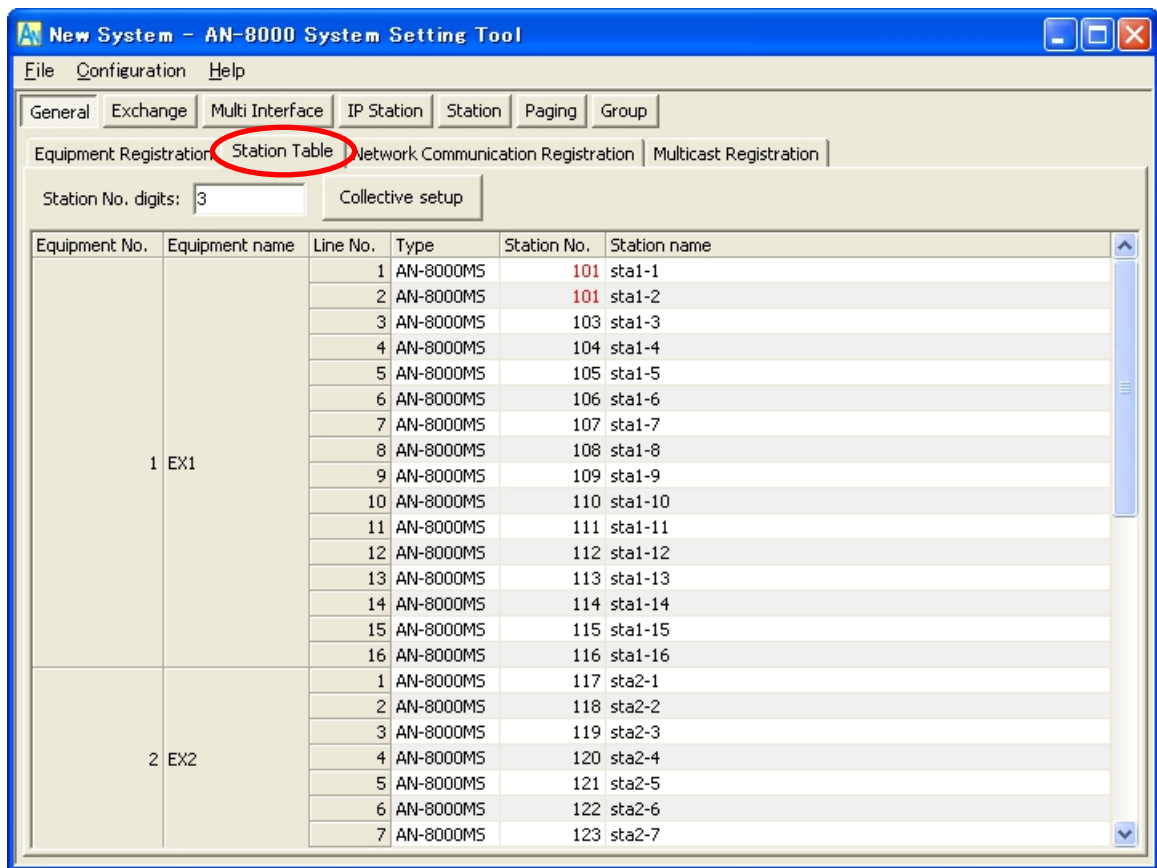

**Step 2.** Enter the station number digits starting from 2 through 6.

**Step 3.** Set each item as follows:

- (1) **Equipment No.** (Can't be edited.)  
 Refers to the equipment number of the exchange to which stations are connected.
- (2) **Equipment name** (Can't be edited.)  
 Refers to the name of the Exchange to which stations are connected.
- (3) **Line No.** (Can't be edited.)  
 Refers to the number of the line to which stations are connected.
- (4) **Type**  
 Allows the type of station to be selected. Setting contents change depending on the type of station selected.
- (5) **Station No.**  
 Refers to the station number used when making a call. Set the number with the same digit length (1 – 3 digits) as that in the Station Number Digit setting.  
**Note**  
 If a duplicated station number is set, it is displayed in red.  
 In this case, reset the number to a different one.

**(6) Station name**

Set the name of each station using up to eight alphanumeric characters. Station names can be displayed on multifunctional stations.

**[Collective setup]**

Pressing the Collective setup button permits station types, station numbers, and station names for all or selected stations to be set all at once.

**Step 1.** Press the Collective setup button.  
The Collective setup window appears.

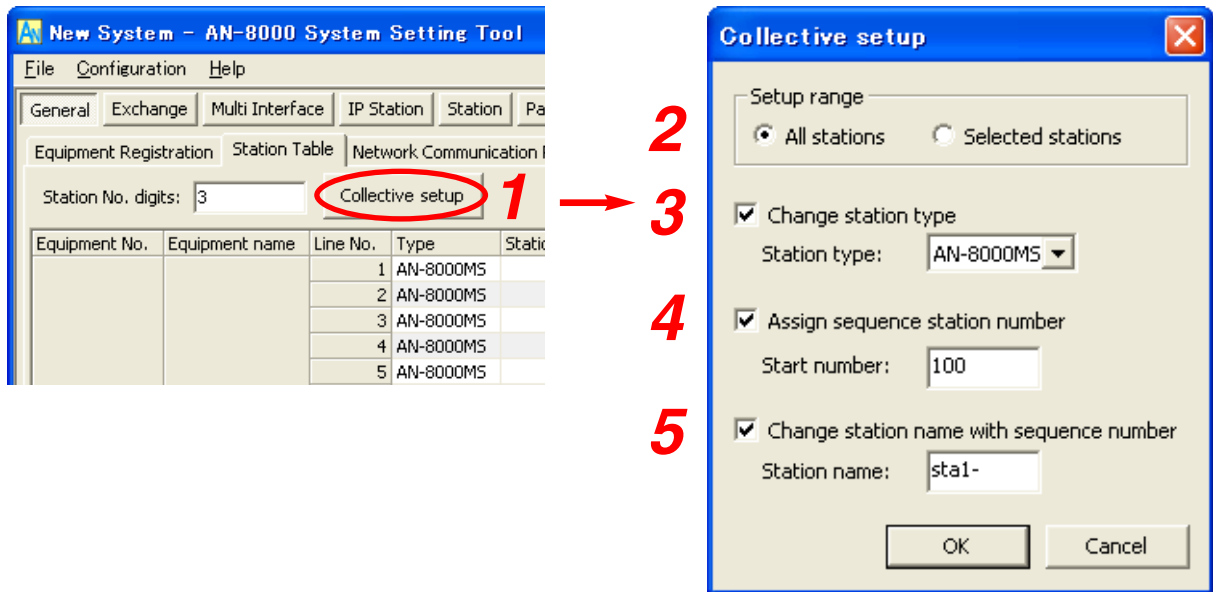

**Step 2.** Select either "All stations" or "Selected stations" for the Setup range.

When "Selected stations" is selected, designate the setup range on the Station Table screen.

To do so, drag the mouse over the station list, or click stations one by one while holding down the Shift key of the PC.

**Step 3.** To change the station type, tick the corresponding box and select the desired type from the pull-down menu.

**Note:** Types of IP stations cannot be set collectively.

**Step 4.** To assign sequence station number, tick the corresponding box and enter the start number.

Example: When "100" is entered for a start number, the station numbers to be automatically set are "100," "101," "102," and so on.

If a set station number comes to the maximum number in the set number digits, no further station number is assigned.

**Step 5.** To change the station name with sequence number, tick the corresponding box and enter a new name.

Up to eight alphanumeric characters including the sequence number can be used.

Example: When a station name "stat1-" is entered, the station names to be automatically set are "sta1-1," "sta1-2," "sta1-3," and so on.

**Step 6.** Press the OK button.



### 5.3.3. Network communications registration

Enables or disables unicast network communications among equipment connected to the network.

**Step 1.** Click "Network Communication Registration" tab to display the following setting screen.

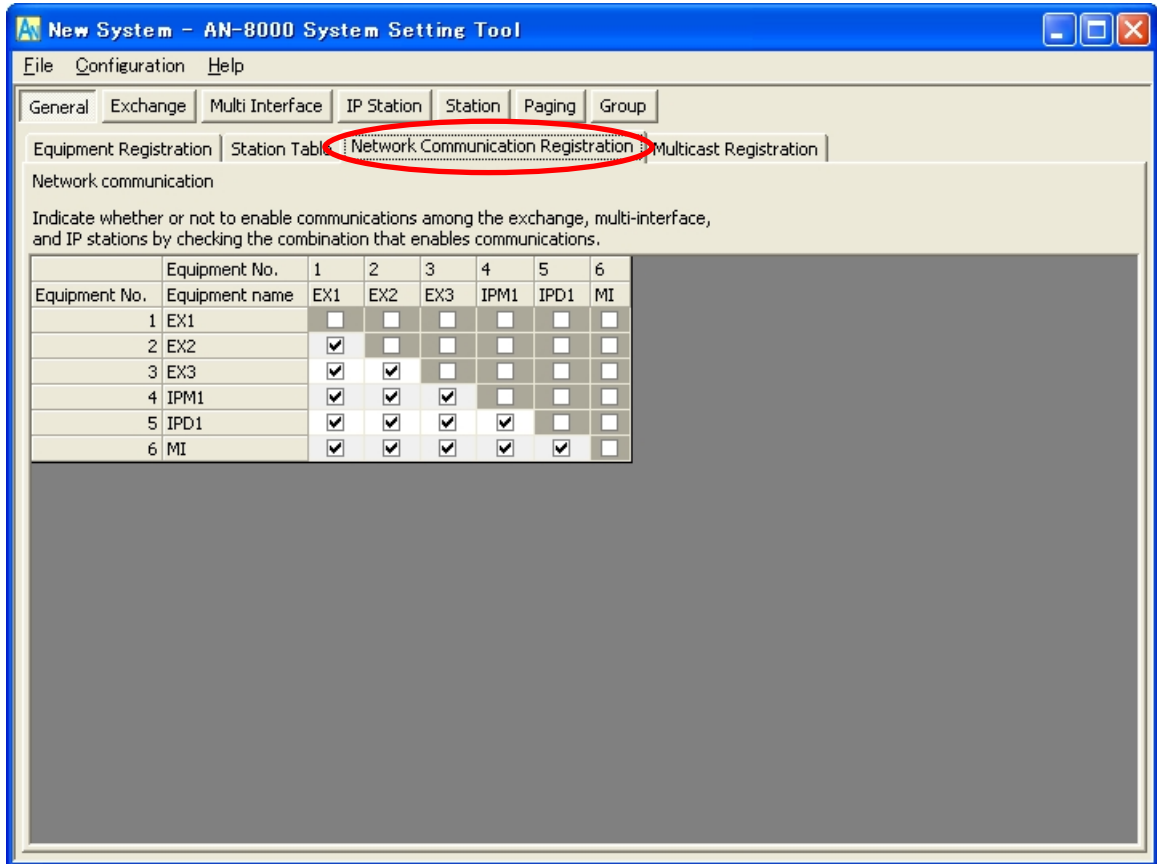

**Step 2.** Select those combinations that enable network communications by clicking the check box.

### 5.3.4. Multicast communications registration

Enables or disables Multicast communications among equipment connected to the network. When multicast communications are an available option, performing this registration conserves network bandwidth by allowing multicast paging.

**Step 1.** Click "Multicast Registration" tab to display the following setting screen.

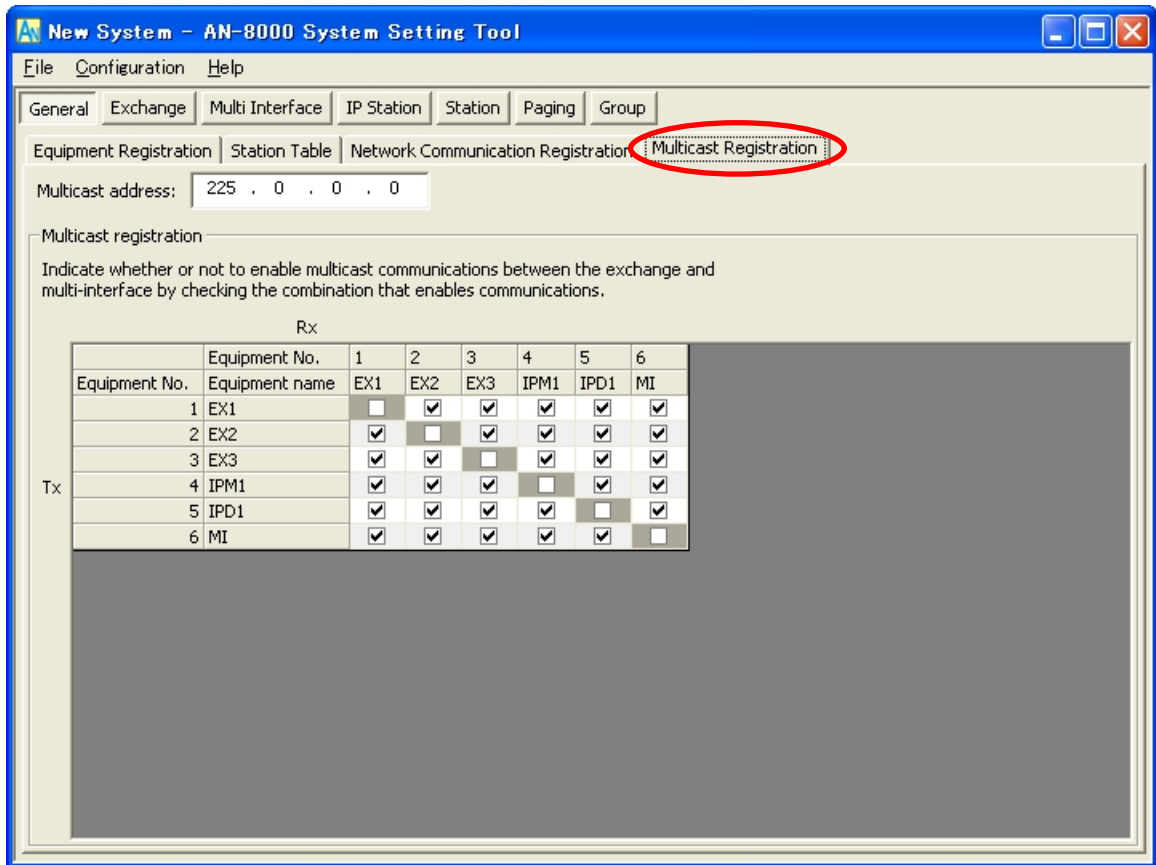

**Step 2.** Enter the multicast address to be used for the system.

**Step 3.** Mark the checkbox associated with the combinations that enable multicast communications.

## 5.4. Exchange Settings

Click "Exchange" to select the exchange to be set.  
Choose the name or number of the exchange from the list.

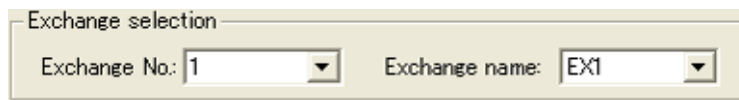

Exchange selection

Exchange No.: 1 Exchange name: EX1

### 5.4.1. Network settings

**Step 1.** Click "Network Settings" tab to display the following setting screen.

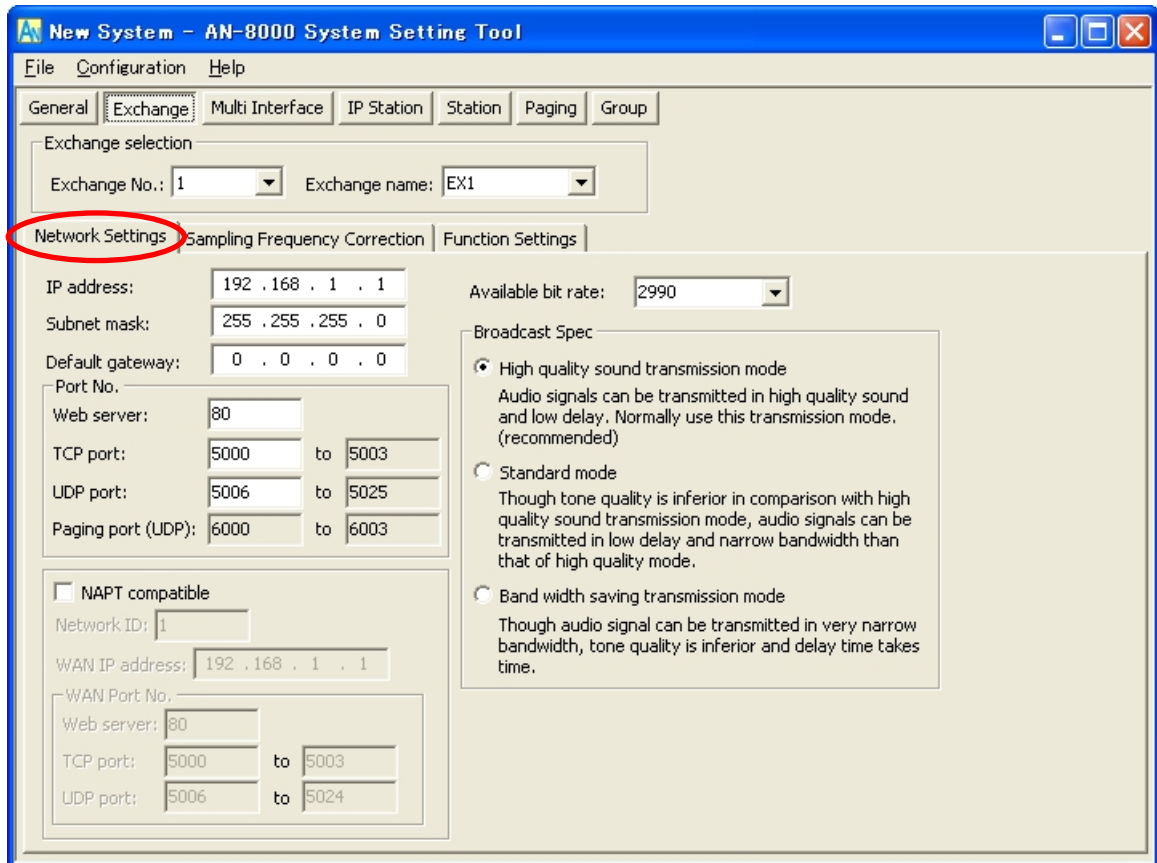

New System - AN-8000 System Setting Tool

File Configuration Help

General Exchange Multi Interface IP Station Station Paging Group

Exchange selection

Exchange No.: 1 Exchange name: EX1

Network Settings Sampling Frequency Correction Function Settings

IP address: 192 . 168 . 1 . 1 Available bit rate: 2990

Subnet mask: 255 . 255 . 255 . 0

Default gateway: 0 . 0 . 0 . 0

Port No.

Web server: 80

TCP port: 5000 to 5003

UDP port: 5006 to 5025

Paging port (UDP): 6000 to 6003

NAPT compatible

Network ID: 1

WAN IP address: 192 . 168 . 1 . 1

WAN Port No.

Web server: 80

TCP port: 5000 to 5003

UDP port: 5006 to 5024

Broadcast Spec

High quality sound transmission mode  
Audio signals can be transmitted in high quality sound and low delay. Normally use this transmission mode. (recommended)

Standard mode  
Though tone quality is inferior in comparison with high quality sound transmission mode, audio signals can be transmitted in low delay and narrow bandwidth than that of high quality mode.

Band width saving transmission mode  
Though audio signal can be transmitted in very narrow bandwidth, tone quality is inferior and delay time takes time.

**Step 2.** Set individual items.

- (1) **IP address**  
Allows entry of the Exchange's IP address.
- (2) **Subnet mask**  
Allows entry of the Subnet mask.
- (3) **Default gateway**  
Allows entry of the Default gateway.

**(4) Port No.**

Set the start port number to be used for each protocol.

[Web server]

Allows entry of the Web server's port number. The valid range is from 1 to 65535. The default factory setting is 80.

[TCP port]

Allows entry of a TCP port start number other than the Web server (valid range from 1 to 65532). The AN-8000 system uses 4 consecutive ports starting with the TCP start port. The default factory setting is 5000.

The TCP port is assigned as follows.

Port	Protocol	Port Number	Default setting
Web server	TCP	Web server	80
Call control	TCP	Port start number + 0	5000
PC monitoring	TCP	Port start number + 1	5001
PC control	TCP	Port start number + 2	5002
Reservation	TCP	Port start number + 3	5003

[UDP port]

Allows entry of UDP port start number to be used (valid range from 1 to 65516). The AN-8000 system uses 20 consecutive ports starting with the UDP start port. The default factory setting is 5006.

The UDP port is assigned as follows.

Port	Protocol	Port Number	Default setting
Reservation	UDP	Port start number + 0	5006
Frequency compensation	UDP	Port start number + 1 to 3	5007 to 5009
Conversation	UDP	Port start number + 4 to 19	5010 to 5025

**Note**

Because UDP port number 15000 is used internally by the system, the numbers from 14981 to 15000 are not available.

[Paging port]

Displays the UDP port number to be used when making paging using the multicast communications. To perform settings, refer to [p. 5-57](#), Paging zone settings.

**(5) NAPT compatible**

When connecting a PC to the exchange using the global IP address, mark the [NAPT compatible] checkbox to make the items from [Network ID (6)] to [WAN port No. (8)] available for input.

**(6) Network ID**

When connecting a PC to the exchange using the global IP address, enter the number that identifies networks for each range accessible by the PC using the local address.

When networks are connected as shown below, for example, assign different ID numbers for each, such as "1" to equipment connected to LAN (1) and "2" to equipment connected to LAN (2).

Network ID No. 1 is assigned to the PC for setting. Set network ID No. 1 to equipment that can be accessed by the PC (for example, equipment connected to LAN 1) using the local address.

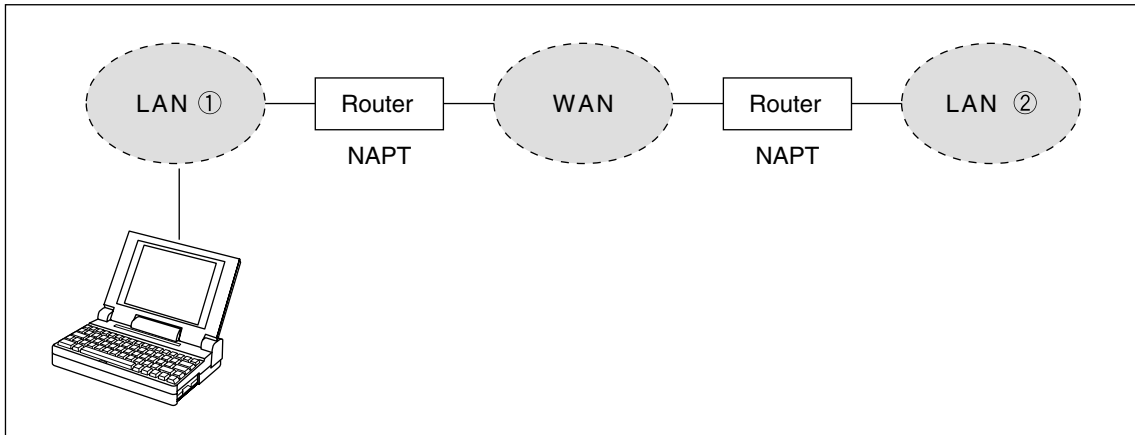
**(7) WAN IP address**

Allows entry of the Exchange's IP address as viewed from the WAN side.

**(8) WAN Port No.**

Set the start port number to be used for each protocol as viewed from the WAN side.

[Web server]

Allows entry of the Web server's port number. The valid range is from 1 to 65535. The default factory setting is 80.

[TCP port]

Allows entry of TCP port start number other than the Web server. The valid range is from 1 to 65532. The AN-8000 system uses 4 consecutive ports starting with the TCP start port. The default factory setting is 5000.

The TCP port is assigned as follows.

Port	Protocol	Port Number	Default setting
Web server	TCP	Web server	80
Call control	TCP	Port start number + 0	5000
PC monitoring	TCP	Port start number + 1	5001
PC control	TCP	Port start number + 2	5002
Reservation	TCP	Port start number + 3	5003

[UDP port]

Allows entry of UDP port start number to be used. (valid range from 1 to 65516) The AN-8000 system uses 20 consecutive ports starting with the UDP start port. The default factory setting is 5006.

The UDP port is assigned as follows.

Port	Protocol	Port Number	Default setting
Reservation	UDP	Port start number + 0	5006
Frequency compensation	UDP	Port start number + 1 to 3	5007 to 5009
Conversation	UDP	Port start number + 4 to 19	5010 to 5025

**(9) Available bit rate**

Set the capacity (or a usable upper limit value) of the network line to which the Exchange is connected. Setting this communication capacity prevents sound quality deterioration and longer time delays caused by excess conversation and/or paging communications traffic.

**(10) Broadcast Spec**

Select the voice transmission mode that is appropriate for the usable frequency band.

- **High Quality Sound Transmission Mode**  
Transmits voices at high sound quality with short time delay. Use this mode as the normal default mode.
- **Standard Mode**  
Transmits voice audio with a short time delay. In this mode, the sound quality is reduced, but the delay time is identical to that in high quality mode, allowing a narrower frequency band to be used. Use this mode when exchanges are connected via an ISDN line (128 kbps).
- **Band Width Saving Transmission Mode**  
Voice transmission uses a very narrow frequency band, but with lesser quality sound and longer time delay. Use this mode when exchanges are connected via an Analog line (56 kbps).

	Sampling frequency	Delay time	Frequency band to be used
High Quality Sound Transmission Mode	16 kHz	0.08 second	130 kbps
Standard Mode	8 kHz	0.08 second	98 kbps
Band Width Saving Transmission Mode	8 kHz	0.32 second	49.5 kbps

## 5.4.2. Sampling frequency correction settings

**Step 1.** Click "Sampling Frequency Correction" tab to display the following setting screen.

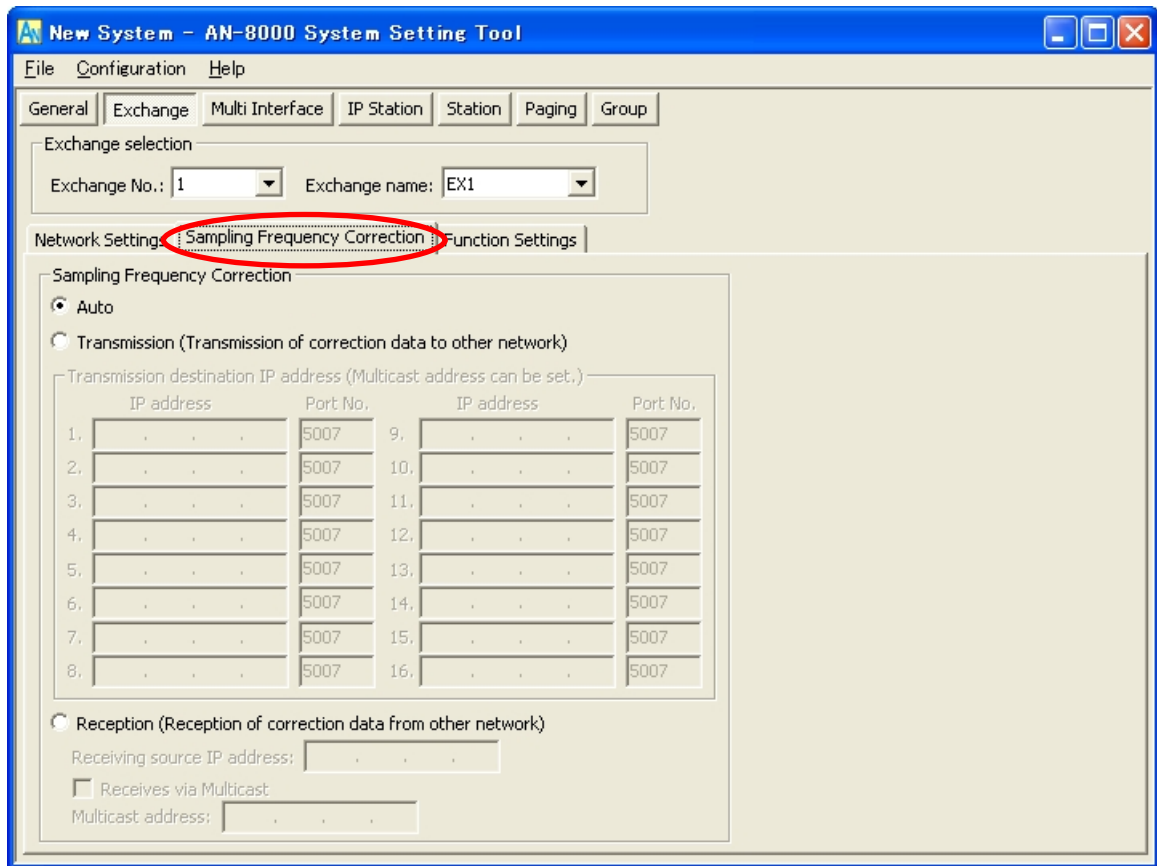

**Step 2.** Set individual items.

### (1) Sampling Frequency Correction

Select this tab when setting the transfer of sampling frequency correction data between different networks. (Correction data is automatically transmitted and received within the range that can receive broadcast packets.)

**Note:** See p. 8-5 regarding sampling frequency correction.

- Auto: Corrects frequency correction data only over the local area network without transferring it to other networks.
- Transmission: Transmits frequency data to other networks. The transmission destination column becomes available for input of transmission destination IP addresses and their port numbers. Up to sixteen destinations can be set. When correcting the sampling frequency using multicast communications, enter the transmission destination's IP address.
- Reception: Receives frequency data from other networks. The receiving source address column becomes available for input of addresses. When transferring frequency data using multicast communications, checkmark "Receives via Multicast" and enter the multicast address to be used.

### 5.4.3. Function settings

**Step 1.** Click "Function Settings" tab to display the following setting screen.

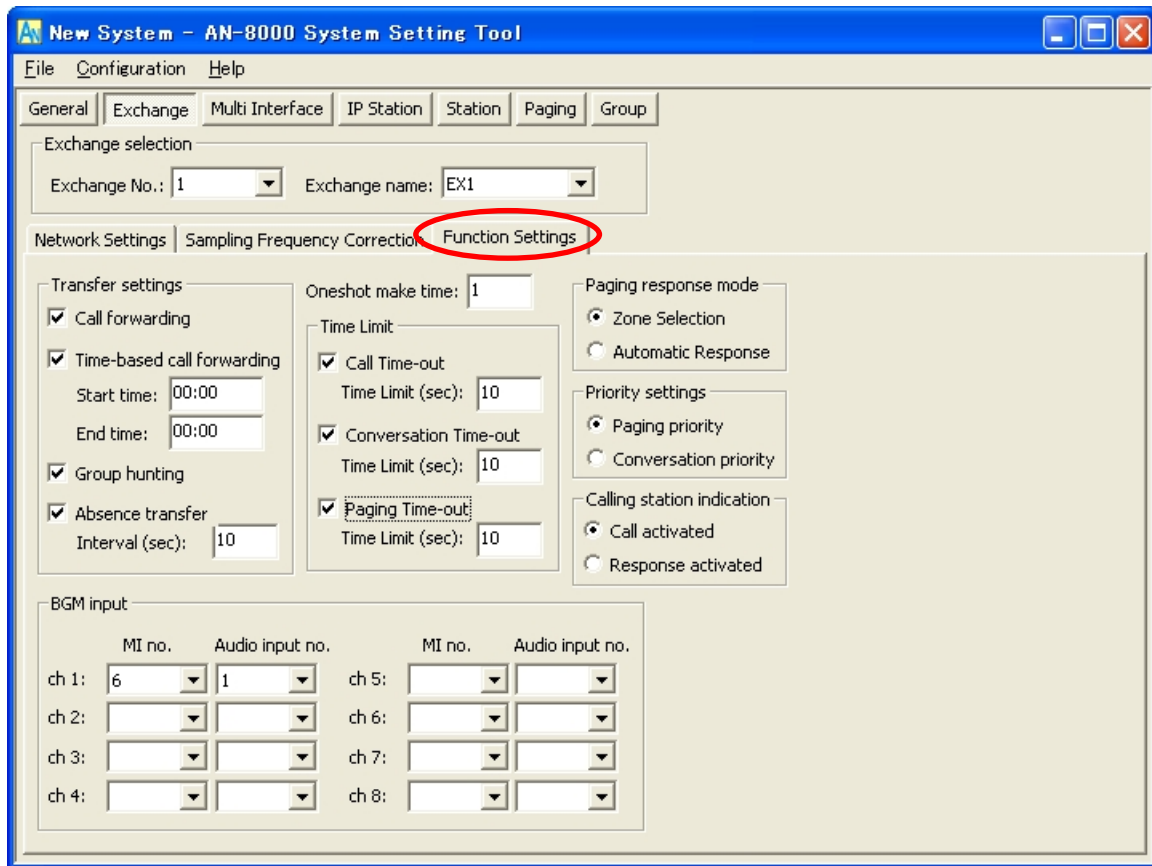

**Step 2.** Set individual items.

#### (1) Transfer settings

Set the transfer function ON or OFF for the station connected to the exchange.

- Call forwarding: Calls to stations are automatically transferred to another designated station without sounding a call tone only when Call forwarding function is enabled.
- Time-based call forwarding: Calls to stations are automatically transferred to another designated station without sounding a call tone only when the preset time is reached. This function can be set only when the call forwarding function is enabled. Preset time can be set only when the time-based call forwarding function is enabled.
- Group hunting: Calls to a busy station are automatically transferred to another designated station, if group hunting function is set to the called station.
- Absence transfer: When no response is made to a call to the station for a set period of time, the call is automatically transferred to another designated station. Preset time duration can be set only when the absence transfer mode is enabled.

#### (2) Oneshot make time (second)

Sets the duration that the external control output terminals are shorted momentarily when the door remote control function is performed.  
The setting range is from 0 to 9 (in 1-second units).  
If not required, set the duration to "0."



**(3) Time Limit**

Set the time-out value for calling, conversation or paging functions in ten-second units between 10 and 990 seconds.

**Call Time-out:** Set whether to limit the duration of a call to the station. If setting a time-out, enter the time limit after which calls to the station are automatically terminated. If not setting a time-out, calls will continue until they are cancelled or the called station responds.

**Conversation Time-out:** Set whether to limit the duration of conversations with the station. If setting a time-out, enter the time limit after which conversations to the station are automatically terminated. If not setting a time-out, conversations will continue until executing the termination operation.

**Paging Time-out:** Set whether to limit the duration of paging call with the station. If setting a time-out, enter the time limit after which paging calls to the station are automatically terminated.  
If not setting a time-out, paging calls will continue until executing the termination operation.

**(4) Paging response mode**

Select either "Zone Selection" or "Automatic Response" modes when responding to the paging.

**Zone Selection:** Responds to a paging call by designating the number of the paging zone. Respond to the paging party who made the paging to the designated zone last is called. Use this mode if paging announcements are heard from multiple zones.

**Automatic Response:** Use only the paging response key to make a response. The responding station is connected to the station that made a paging call over the paging zone through which the responding station last received a call.

**(5) Priority settings**

Sets whether paging calls or conversations should take precedence when these occur simultaneously.

**Paging priority:** When a call is received while receiving a paging call, the called station becomes busy and the paging call is gone through. Station keys cannot be used while receiving a paging call. (Paging response cannot be performed at a paging receiving station, either.)

**Conversation priority:** A paging call is not received when paged during a conversation or dialing operation. Station keys can be dialed even while receiving a paging call.

**(6) Calling station indication**

Select either "Call activated" or "Response activated" mode when performing the calling station indication function.

**Call activated:** The contact closes when the station initiates a call, and opens when the station terminates the call.

**Response activated:** The contact closes when the station responds to a call, and opens when the station terminates the call.

**(7) BGM input**

Set BGM to be heard at the stations connected to the selected exchange.

Select the unit's number and audio input number of the multi interface unit to which the BGM sound sources are connected.

## 5.5. Multi Interface Unit Settings

Click "Multi Interface" to select the multi interface unit to be set.  
Choose the name or number of the multi interface unit from the list.



A dialog box titled "Multi-interface selection" with two dropdown menus. The first dropdown is labeled "Multi-interface No.:" and has the value "5" selected. The second dropdown is labeled "Multi-interface Name.:" and has the value "MI" selected.

### 5.5.1. Network settings

**Step 1.** Click "Network Settings" tab to display the following setting screen.

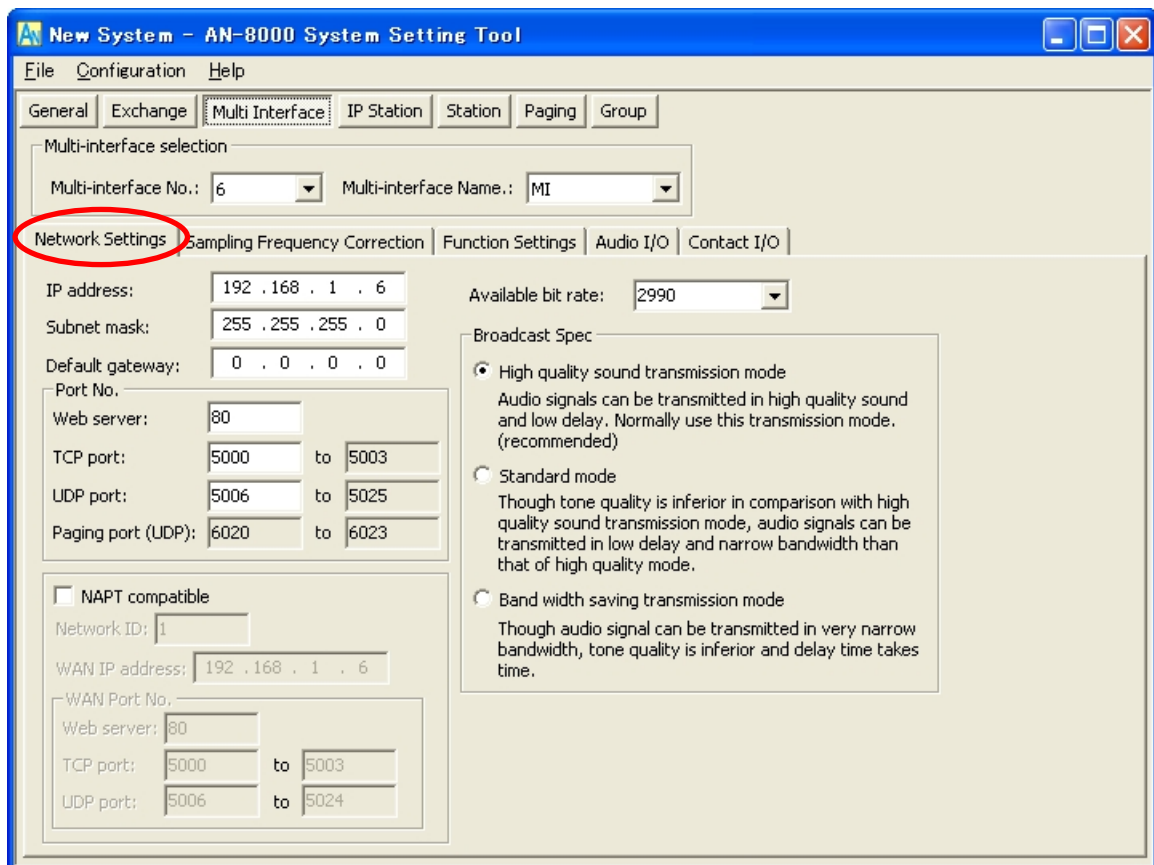

The screenshot shows the "AN-8000 System Setting Tool" window with the "Multi Interface" tab selected. The "Network Settings" sub-tab is highlighted with a red circle. The "Multi-interface selection" section at the top shows "Multi-interface No.:" set to 6 and "Multi-interface Name.:" set to MI. The "Network Settings" section includes fields for IP address (192.168.1.6), Subnet mask (255.255.255.0), and Default gateway (0.0.0.0). The "Available bit rate" is set to 2990. The "Broadcast Spec" section has three radio button options: "High quality sound transmission mode" (selected), "Standard mode", and "Band width saving transmission mode". The "NAPT compatible" section is unchecked and includes fields for Network ID (1), WAN IP address (192.168.1.6), and WAN Port No. (80). The "Web server" field is set to 80. The "TCP port" is set to 5000 to 5003, and the "UDP port" is set to 5006 to 5024.

**Step 2.** Set individual items.

**(1) IP address**

Allows entry of the multi interface unit's IP address.

**(2) Subnet mask**

Allows entry of the Subnet mask.

**(3) Default gateway**

Allows entry of the Default gateway.

**(4) Port No.**

Set the start port number to be used for each protocol.

[Web server]

Allows entry of the Web server's port number. The valid range is from 1 to 65535. The default factory setting is 80.

[TCP port]

Allows entry of a TCP port start number other than the Web server (valid range from 1 to 65532). The AN-8000 system uses 4 consecutive ports starting with the TCP start port. The default factory setting is 5000.

The TCP port is assigned as follows.

Port	Protocol	Port Number	Default setting
Web server	TCP	Web server	80
Call control	TCP	Port start number + 0	5000
PC monitoring	TCP	Port start number + 1	5001
PC control	TCP	Port start number + 2	5002
Reservation	TCP	Port start number + 3	5003

[UDP port]

Allows entry of UDP port start number to be used (valid range from 1 to 65516). The AN-8000 system uses 20 consecutive ports starting with the UDP start port. The default factory setting is 5006.

The UDP port is assigned as follows.

Port	Protocol	Port Number	Default setting
Reservation	UDP	Port start number + 0	5006
Frequency compensation	UDP	Port start number + 1 to 3	5007 to 5009
Conversation	UDP	Port start number + 4 to 19	5010 to 5025

**Note**

Because UDP port number 15000 is used internally by the system, the numbers from 14981 to 15000 are not available.

[Paging port]

Displays the UDP port number to be used when making paging using the multicast communications. To perform settings, refer to [p. 5-57](#), Paging zone settings.

**(5) NAPT compatible**

When connecting a PC to the Multi interface unit using the global IP address, mark the [NAPT compatible] checkbox to make the items from [Network ID (6)] to [WAN port No. (8)] available for input.

**(6) Network ID**

When connecting a PC to the multi interface unit using the global IP address, enter the number that identifies networks for each range accessible by the PC using the local address.

When networks are connected as shown below, for example, assign different ID numbers for each, such as "1" to equipment connected to LAN (1) and "2" to equipment connected to LAN (2).

Network ID No. 1 is assigned to the PC for setting. Set network ID No. 1 to equipment that can be accessed by the PC (for example, equipment connected to LAN 1) using the local address.

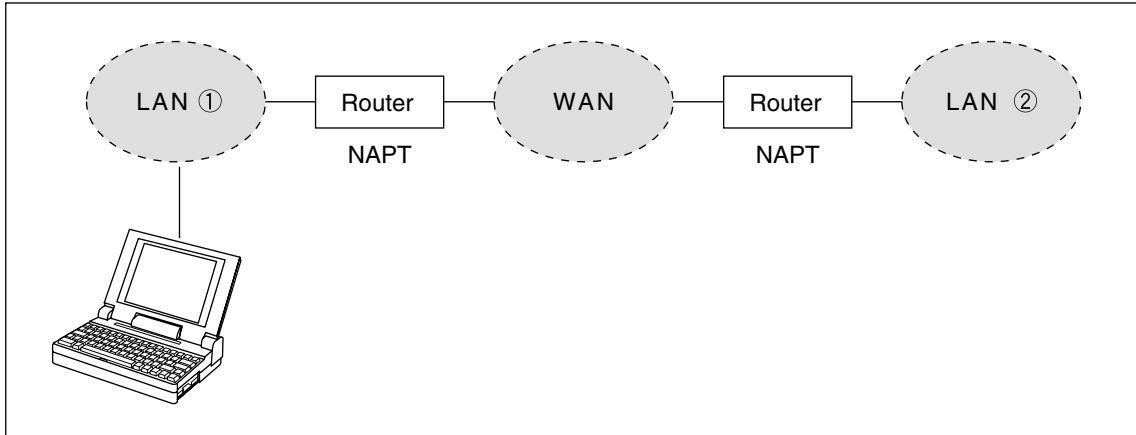

**(7) WAN IP address**

Allows entry of the Multi interface unit's IP address as viewed from the WAN side.

**(8) WAN Port No.**

Set the start port number to be used for each protocol as viewed from the WAN side.

[Web server]

Allows entry of the Web server's port number. The valid range is from 1 to 65535. The default factory setting is 80.

[TCP port]

Allows entry of TCP port start number other than the Web server. The valid range is from 1 to 65532. The AN-8000 system uses 4 consecutive ports starting with the TCP start port. The default factory setting is 5000.

The TCP port is assigned as follows.

Port	Protocol	Port Number	Default setting
Web server	TCP	Web server	80
Call control	TCP	Port start number + 0	5000
PC monitoring	TCP	Port start number + 1	5001
PC control	TCP	Port start number + 2	5002
Reservation	TCP	Port start number + 3	5003

[UDP port]

Allows entry of UDP port start number to be used. (valid range from 1 to 65516) The AN-8000 system uses 20 consecutive ports starting with the UDP start port. The default factory setting is 5006.

The UDP port is assigned as follows.

Port	Protocol	Port Number	Default setting
Reservation	UDP	Port start number + 0	5006
Frequency compensation	UDP	Port start number + 1 to 3	5007 to 5009
Conversation	UDP	Port start number + 4 to 19	5010 to 5025

**(9) Available bit rate**

Set the capacity (or a usable upper limit value) of the network line to which the Multi interface unit is connected. Setting this communication capacity prevents sound quality deterioration and longer time delays caused by excess conversation and/or paging communications traffic.

**(10) Broadcast Spec**

Select the voice transmission mode that is appropriate for the usable frequency band.

- High Quality Sound Transmission Mode

Transmits voices at high sound quality with short time delay. Use this mode as the normal default mode. Also use this mode when BGM sound sources are connected.

- Standard Mode

Transmits voice audio with a short time delay. In this mode, the sound quality is reduced, but the delay time is identical to that in high quality mode, allowing a narrower frequency band to be used. Use this mode when multi interface units are connected via an ISDN line (128 kbps).

- Band Width Saving Transmission Mode

Voice transmission uses a very narrow frequency band, but with lesser quality sound and longer time delay. Use this mode when multi interface units are connected via an Analog line (56 kbps).

	Sampling frequency	Delay time	Frequency band to be used
High Quality Sound Transmission Mode	16 kHz	0.08 second	130 kbps
Standard Mode	8 kHz	0.08 second	98 kbps
Band Width Saving Transmission Mode	8 kHz	0.32 second	49.5 kbps

## 5.5.2. Sampling frequency correction settings

**Step 1.** Click "Sampling Frequency Correction" tab to display the following setting screen.

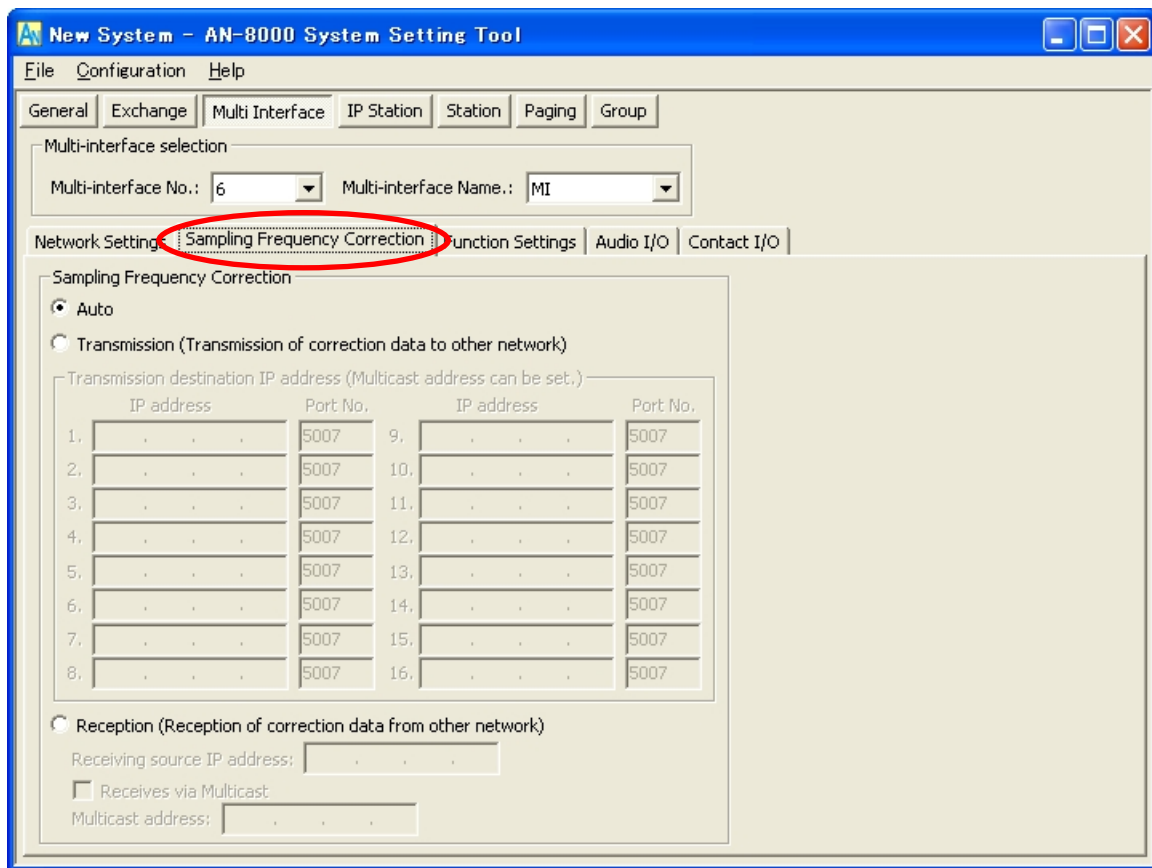

**Step 2.** Set individual items.

### (1) Sampling Frequency Correction

Select this tab when setting the transfer of sampling frequency correction data between different networks. (Correction data is automatically transmitted and received within the range that can receive broadcast packets.)

**Note:** See p. 8-5 regarding sampling frequency correction.

**Auto:** Corrects frequency correction data only over the local area network without transferring it to other networks.

**Transmission:** Transmits frequency data to other networks. The transmission destination column becomes available for input of transmission destination IP addresses and their port numbers. Up to sixteen destinations can be set. When correcting the sampling frequency using multicast communications, enter the transmission destination's IP address.

**Reception:** Receives frequency data from other networks. The receiving source address column becomes available for input of addresses. When transferring frequency data using multicast communications, checkmark "Receives via Multicast" and enter the multicast address to be used.

### 5.5.3. Function settings

**Step 1.** Click "Function Settings" tab to display the following setting screen.

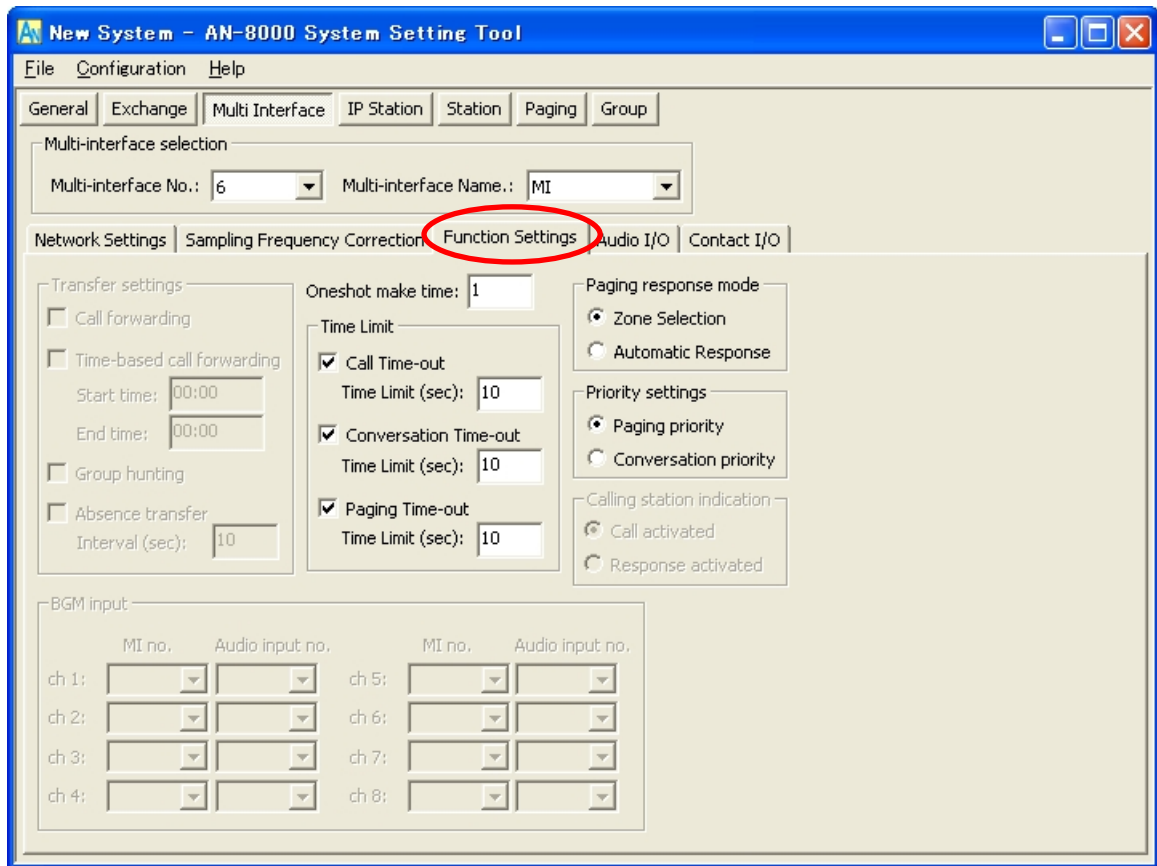

**Step 2.** Set individual items.

#### (1) Oneshot make time (second)

Sets the duration that the external control output terminals are shorted momentarily when the door remote control function is performed.  
The setting range is from 0 to 9 (in 1-second units).  
If not required, set the duration to "0."

#### (2) Time Limit

Set the time-out value for calling, conversation or paging functions in ten-second units between 10 and 990 seconds.

**Call Time-out:** Set whether to limit the duration of a call to the station. If setting a timeout, enter the time limit after which calls to the station are automatically terminated. If not setting a timeout, calls will continue until they are cancelled or the called station responds.

**Conversation Time-out:** Set whether to limit the duration of conversations with the station. If setting a timeout, enter the time limit after which conversations to the station are automatically terminated. If not setting a timeout, conversations will continue until executing the termination operation.

**Paging Time-out:** Set whether to limit the duration of paging call with the station. If setting a timeout, enter the time limit after which paging calls to the station are automatically terminated.  
If not setting a timeout, paging calls will continue until executing the termination operation.

**(3) Paging response mode**

Select either "Zone Selection" or "Automatic Response" modes when responding to the paging.

**Zone Selection:** Responds to a paging call by designating the number of the paging zone. Respond to the paging party who made the paging to the designated zone last is called. Use this mode if paging announcements are heard from multiple zones.

**Automatic Response:** Use only the paging response key to make a response. The responding station is connected to the station that made a paging call over the paging zone through which the responding station last received a call.

**(4) Priority settings**

Sets whether paging calls or conversations should take precedence when these occur simultaneously.

**Paging priority:** When a call is received while receiving a paging call, the called station becomes busy and the paging call is gone through. Station keys cannot be used while receiving a paging call.

**Conversation priority:** A paging call is not received when paged during a conversation or dialing operation. Station keys can be dialed even while receiving a paging call.



### 5.5.4. Audio I/O settings

**Step 1.** Click on the Audio I/O tab.

The corresponding setting screen is displayed.

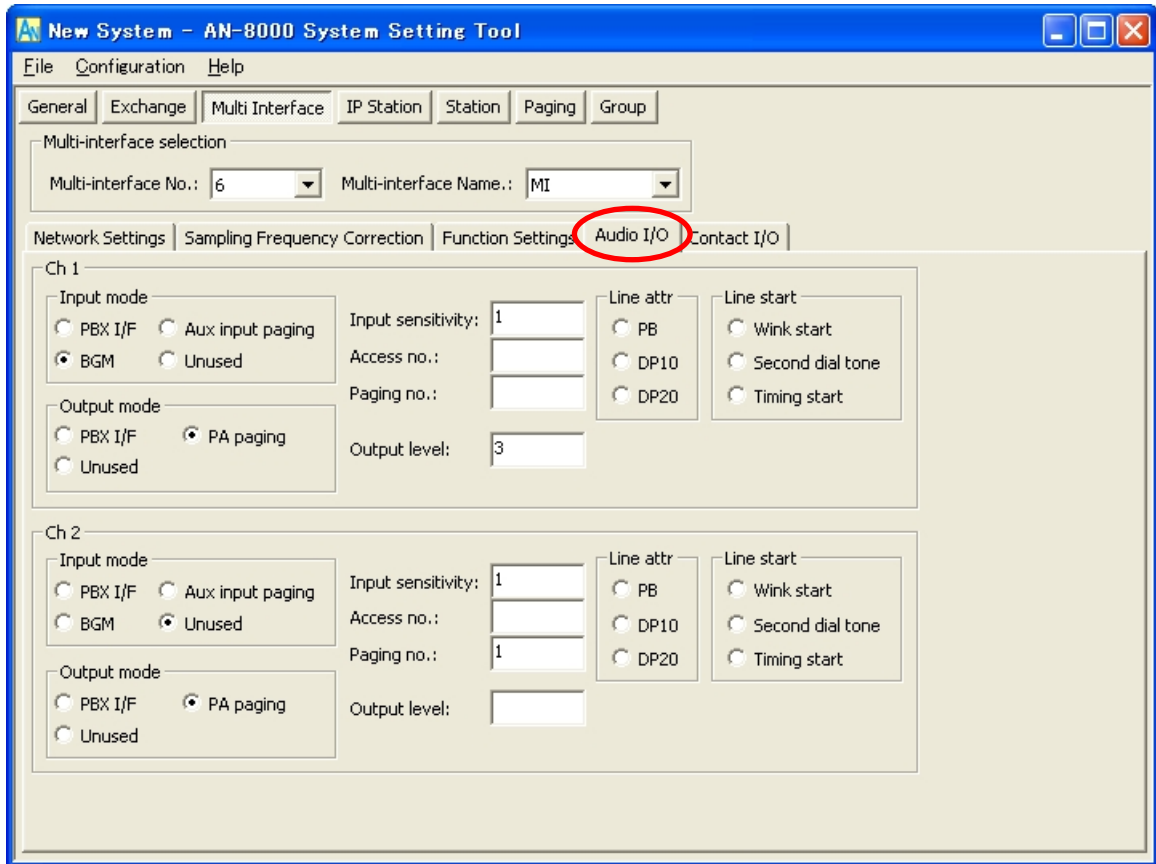

**Step 2.** Perform settings for each item of Audio I/O Ch 1 and Ch 2.

Set how to use the Multi-interface unit's Audio input and output terminals. The following setting items are provided in Audio I/O Ch1 and Ch2.

#### (1) Input mode

Set the operation mode to be used.

If "PBX interface" is selected, the output mode is also automatically set to the same contents.

- PBX I/F:** Select this item when connecting the Multi interface to the PBX analog E&M interface.
- Aux input paging:** Select this item when connecting the Multi interface unit to playback components or Remote microphone to make paging calls. Paging calls can be made to the preprogrammed paging zones when the control input is activated.
- BGM:** Select this item when broadcasting BGM to the stations in standby mode by connecting playback components.
- Unused:** The audio input is not used.

**(2) Output mode**

Setting "Input mode" to "Aux input paging," "BGM" or "Unused" permits "PA paging" to be selected.

PBX I/F: Select this item when connecting the Multi interface unit to the PBX analog E&M interface.

PA paging: Select this item when connecting the amplifier, etc. for PA paging.

Unused: The audio output is not used.

**(3) Input sensitivity**

Setting "Input mode" to "PBX I/F" permits the input sensitivity to be set.

Set the sensitivity level in 4 increments of 1 – 4. "1" (default) is the minimum and "4" is maximum. (5 dB per step)

**(4) Access No.**

Setting "Input mode" to "PBX I/F" permits the access number to be set. Set the access number between 0 and 99 (single or double digit), which is used when the Multi interface unit is connected to different series intercom system or when making calls to a PBX.

**(5) Paging No.**

Setting "Input mode" to "Aux input paging" permits the paging zone to be set.

Enter the paging zone number.

**(6) Output level**

Setting "Input mode" to "PBX I/F" permits the output level to be set.

Set the sensitivity level in 4 increments of 1 – 4. "1" is the minimum and "4" (default) is maximum. (5 dB per step)

**(7) Line attr (Line attribute)**

Choose a line attribute from "PB," "DP10," and "DP20."

**(8) Line start**

Setting "Input mode" to "PBX I/F" permits the line start method to be set. Choose the line start method from "Wink start," "Second dial tone," and "Timing start" signaling methods, which are defined as follows.

**Wink start signaling method**

After sending a start signal, a calling device sends a selective signal when it detects the acknowledgment signal (140 to 290 ms contact-closure pulse) from the called device.

**Second dial tone signaling method**

After sending a start signal, a calling device sends a selective signal when it detects the dial tone from the called device.

**Timing start signaling method**

After sending a start signal, a calling device sends a selective signal after 3 seconds have passed.

### 5.5.5. Contact setting

**Step 1.** Click on the Contact I/O tab. The setting screen is displayed.

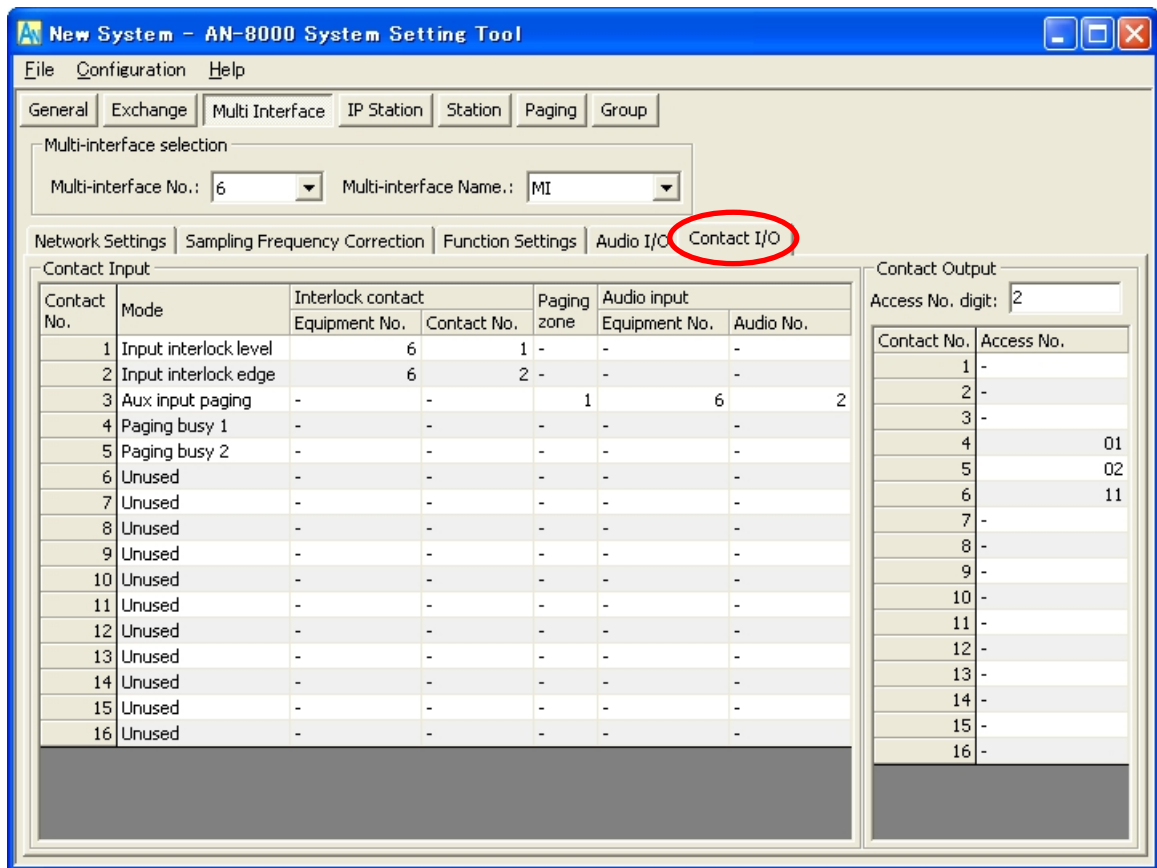

**Step 2.** Set each item of "Contact input."

**(1) Contact No.** (Can't be edited.)

The Multi interface unit's contact input terminal number.

**(2) Mode**

Select the contact input's operation mode. The setting contents differ depending on the mode selected here.

**Input interlock level:** Select this item when closing the contact output terminal in synchronization with the contact input terminal as shown below. (The input is defined when its level remains constant for 50 ms after change.)

**Input interlock edge:** Select this item when closing the contact output terminal in synchronization with the contact input terminal as shown below. (The input is defined when its level remains constant for 50 ms after change.)

[Input interlock level]

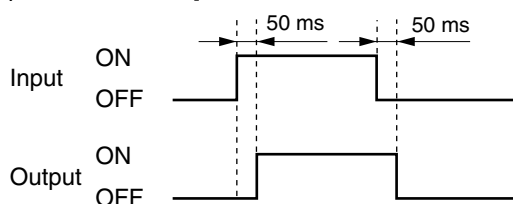

[Input interlock edge]

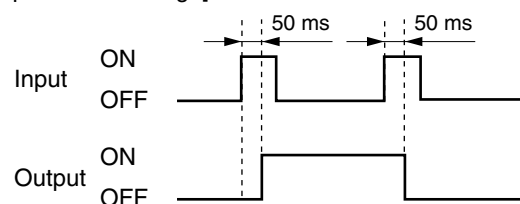

Aux input paging:	Select this item when activating playback components or other devices connected to the Multi interface unit's audio input terminal from the control input.
Paging busy 1:	Select this item when sending externally-connected paging equipment's busy status data to the Audio output 1.
Paging busy 2:	Select this item when sending externally-connected paging equipment's busy status data to the Audio output 2.
Unused:	The contact input is not used.

**(3) Interlock contact**

Set the contact numbers (Multi interface unit's unit number and contact output terminal number) to be output when "Input interlock level" or "Input interlock edge" is selected in the mode setting.

**(4) Paging zone**

Set the paging zone numbers when "Aux input paging" is selected in the mode setting.

**(5) Audio input**

Set the terminal number to which paging sound source is to be input (Multi interface unit's unit number\* and audio input terminal number) when "Aux input paging" is selected in the mode setting.

\* Currently selected Multi interface unit's unit number.

**Step 3.** Set each item of "Contact output."

Set the access number for the contact output terminal to be activated when the station performs external equipment control (one-shot make output or make/break output).

**(1) Access No. digit**

Enter 2 – 4 digit numbers to be used when controlling external equipment at the station.

**(2) Contact No. (Can't be edited.)**

The Multi interface unit's contact output terminal number.

**(3) Access No.**

Set the access number of the digit set in "Access No. digit", which is used at the station.

## 5.6. Setting IP Stations

Click "IP Station" to select the IP station to be set.

Choose the number of the IP station, station number or station name from the list.



A dialog box titled "Station selection" with three dropdown menus. The first is labeled "Unit No.:" and contains the value "4". The second is labeled "Station No.:" and contains the value "149". The third is labeled "Station name:" and contains the value "IPM1".

### 5.6.1. Network settings

**Step 1.** Click "Network Settings" tab to display the following setting screen.

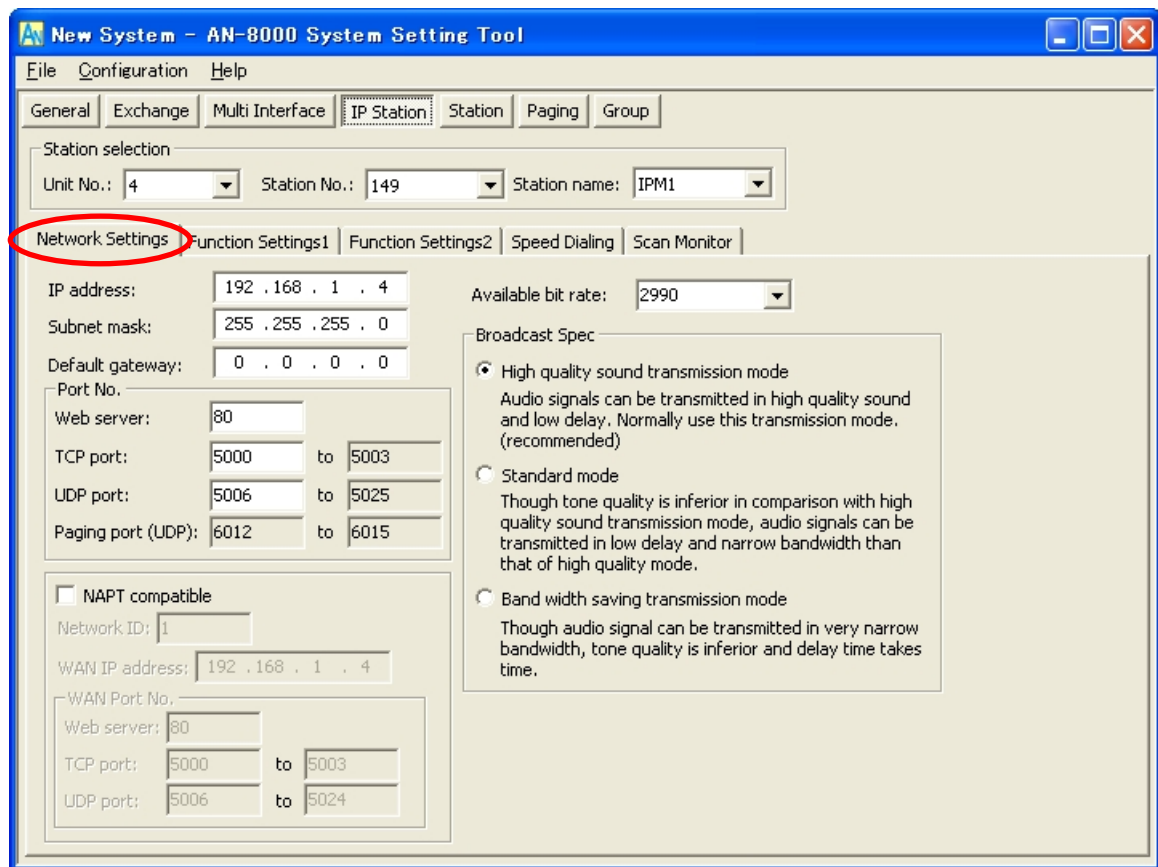

The screenshot shows the "AN-8000 System Setting Tool" window. The "IP Station" tab is selected. The "Network Settings" sub-tab is highlighted with a red circle. The "Station selection" section at the top shows "Unit No.: 4", "Station No.: 149", and "Station name: IPM1". The "Network Settings" section includes fields for "IP address: 192 . 168 . 1 . 4", "Subnet mask: 255 . 255 . 255 . 0", and "Default gateway: 0 . 0 . 0 . 0". There are also fields for "Web server: 80", "TCP port: 5000 to 5003", and "UDP port: 5006 to 5025". A "NAPT compatible" checkbox is checked, with "Network ID: 1" and "WAN IP address: 192 . 168 . 1 . 4". The "Broadcast Spec" section has three radio buttons: "High quality sound transmission mode" (selected), "Standard mode", and "Band width saving transmission mode".

**Step 2.** Set individual items.

- (1) **IP address**  
Allows entry of the IP station's IP address.
- (2) **Subnet mask**  
Allows entry of the Subnet mask.
- (3) **Default gateway**  
Allows entry of the Default gateway.

**(4) Port No.**

Set the start port number to be used for each protocol.

[Web server]

Allows entry of the Web server's port number. The valid range is from 1 to 65535. The default factory setting is 80.

[TCP port]

Allows entry of a TCP port start number other than the Web server (valid range from 1 to 65532). The AN-8000 system uses 4 consecutive ports starting with the TCP start port. The default factory setting is 5000.

The TCP port is assigned as follows.

Port	Protocol	Port Number	Default setting
Web server	TCP	Web server	80
Call control	TCP	Port start number + 0	5000
PC monitoring	TCP	Port start number + 1	5001
PC control	TCP	Port start number + 2	5002
Reservation	TCP	Port start number + 3	5003

[UDP port]

Allows entry of UDP port start number to be used (valid range from 1 to 65516). The AN-8000 system uses 20 consecutive ports starting with the UDP start port. The default factory setting is 5006.

The UDP port is assigned as follows.

Port	Protocol	Port Number	Default setting
Reservation	UDP	Port start number + 0	5006
Frequency compensation	UDP	Port start number + 1 to 3	5007 to 5009
Conversation	UDP	Port start number + 4 to 19	5010 to 5025

**Note**

Because UDP port number 15000 is used internally by the system, the numbers from 14981 to 15000 are not available.

[Paging port]

Displays the UDP port number to be used when making paging using the multicast communications. To perform settings, refer to [p. 5-57](#), Paging zone settings.

**(5) NAPT compatible**

When connecting a PC to the IP station using the global IP address, mark the [NAPT compatible] checkbox to make the items from [Network ID (6)] to [WAN port No. (8)] available for input.

**(6) Network ID**

When connecting a PC to the IP station using the global IP address, enter the number that identifies networks for each range accessible by the PC using the local address.

When networks are connected as shown below, for example, assign different ID numbers for each, such as "1" to equipment connected to LAN (1) and "2" to equipment connected to LAN (2).

Network ID No. 1 is assigned to the PC for setting. Set network ID No. 1 to equipment that can be accessed by the PC (for example, equipment connected to LAN 1) using the local address.

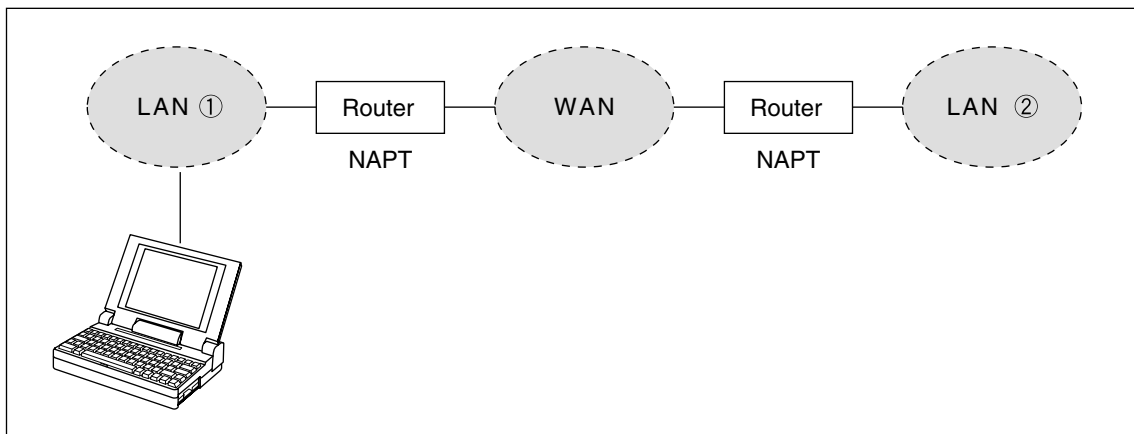
**(7) WAN IP address**

Allows entry of the IP station's IP address as viewed from the WAN side.

**(8) WAN Port No.**

Set the start port number to be used for each protocol as viewed from the WAN side.

[Web server]

Allows entry of the Web server's port number. The valid range is from 1 to 65535. The default factory setting is 80.

[TCP port]

Allows entry of TCP port start number other than the Web server. The valid range is from 1 to 65532. The AN-8000 system uses 4 consecutive ports starting with the TCP start port. The default factory setting is 5000.

The TCP port is assigned as follows.

Port	Protocol	Port Number	Default setting
Web server	TCP	Web server	80
Call control	TCP	Port start number + 0	5000
PC monitoring	TCP	Port start number + 1	5001
PC control	TCP	Port start number + 2	5002
Reservation	TCP	Port start number + 3	5003

[UDP port]

Allows entry of UDP port start number to be used. (valid range from 1 to 65516) The AN-8000 system uses 20 consecutive ports starting with the UDP start port. The default factory setting is 5006.

The UDP port is assigned as follows.

Port	Protocol	Port Number	Default setting
Reservation	UDP	Port start number + 0	5006
Frequency compensation	UDP	Port start number + 1 to 3	5007 to 5009
Conversation	UDP	Port start number + 4 to 19	5010 to 5025

**(9) Available bit rate**

Set the capacity (or a usable upper limit value) of the network line to which the Multi interface unit is connected. Setting this communication capacity prevents sound quality deterioration and longer time delays caused by excess conversation and/or paging communications traffic.

**(10) Broadcast Spec**

Select the voice transmission mode that is appropriate for the usable frequency band.

- High Quality Sound Transmission Mode  
Transmits voices at high sound quality with short time delay. Use this mode as the normal default mode.
- Standard Mode  
Transmits voice audio with a short time delay. In this mode, the sound quality is reduced, but the delay time is identical to that in high quality mode, allowing a narrower frequency band to be used. Use this mode when IP stations are connected via an ISDN line (128 kbps).
- Band Width Saving Transmission Mode  
Voice transmission uses a very narrow frequency band, but with lesser quality sound and longer time delay. Use this mode when IP stations are connected via an Analog line (56 kbps).

	Sampling frequency	Delay time	Frequency band to be used
High Quality Sound Transmission Mode	16 kHz	0.08 second	130 kbps
Standard Mode	8 kHz	0.08 second	98 kbps
Band Width Saving Transmission Mode	8 kHz	0.32 second	49.5 kbps



## 5.6.2. Function settings

**Step 1.** Click "Function Settings 1" tab to display the following setting screen.

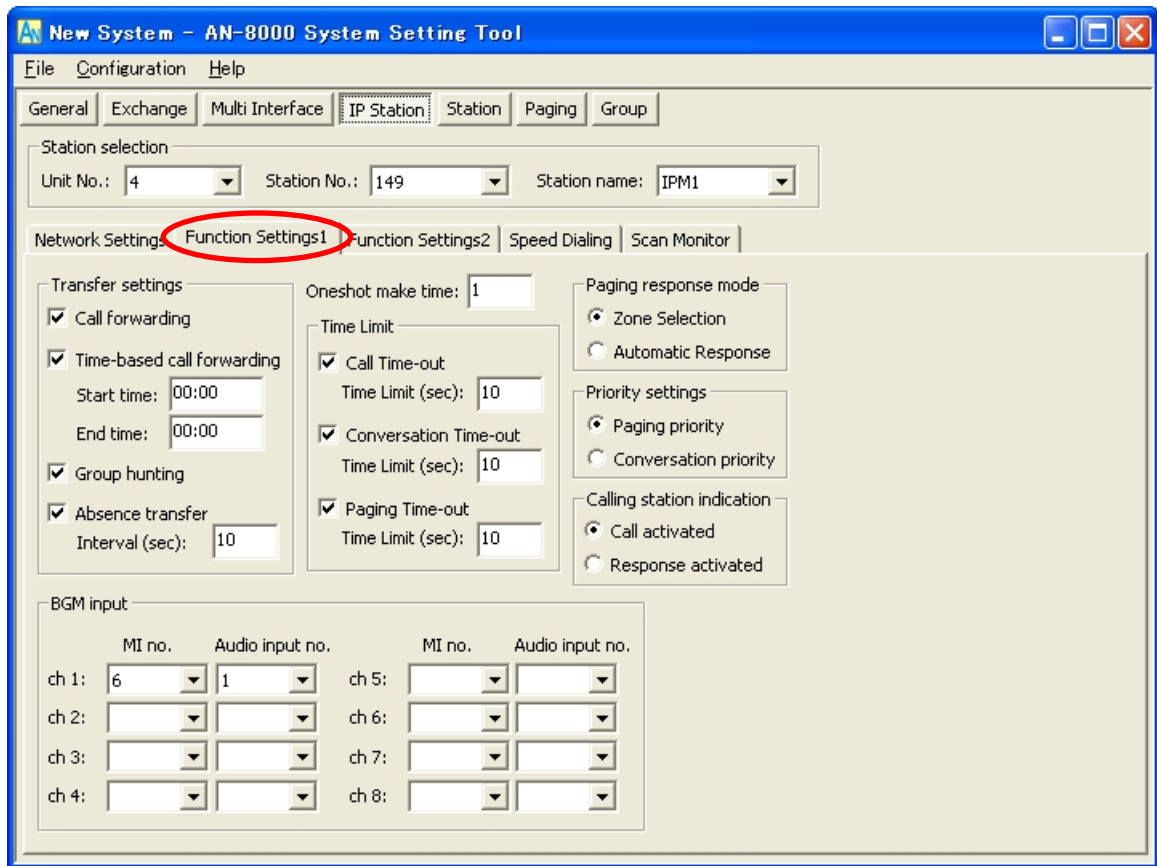

Available item differs depending on the type of IP stations.

**Step 2.** Set individual items.

### (1) Transfer settings (IP master station only)

Set the transfer function ON or OFF.

- Call forwarding:** Calls to stations are automatically transferred to another designated station without sounding a call tone only when Call forwarding function is enabled.
- Time-based call forwarding:** Calls to stations are automatically transferred to another designated station without sounding a call tone only when the preset time is reached. Preset time can be set only when the time-based call forwarding function is enabled.
- Group hunting:** Calls to a busy station are automatically transferred to another designated station, if group hunting function is set to the called station.
- Absence transfer:** When no response is made to a call to the station for a set period of time, the call is automatically transferred to another designated station. Preset time duration can be set only when the absence transfer mode is enabled.

### (2) Oneshot make time (second)

Sets the duration that the external control output terminals are shorted momentarily when the door remote control function is performed.  
 The setting range is from 0 to 9 (in 1-second units).  
 If not required, set the duration to "0."

**(3) Time Limit**

Set the time-out value for calling, conversation or paging functions in ten-second units between 10 and 990 seconds.

**Call Time-out:** Set whether to limit the duration of a call to the station. If setting a time-out, enter the time limit after which calls to the station are automatically terminated. If not setting a time-out, calls will continue until they are cancelled or the called station responds.

**Conversation Time-out:** Set whether to limit the duration of conversations with the station. If setting a time-out, enter the time limit after which conversations to the station are automatically terminated. If not setting a time-out, conversations will continue until executing the termination operation.

**Paging Time-out (IP master station only):**

Set whether to limit the duration of paging call with the station. If setting a time-out, enter the time limit after which paging calls to the station are automatically terminated.

If not setting a time-out, paging calls will continue until executing the termination operation.

**(4) Paging response mode (IP master station only)**

Select either "Zone Selection" or "Automatic Response" modes when responding to the paging.

**Zone Selection:** Responds to a paging call by designating the number of the paging zone. Respond to the paging party who made the paging to the designated zone last is called. Use this mode if paging announcements are heard from multiple zones.

**Automatic Response:** Use only the paging response key to make a response. The responding station is connected to the station that made a paging call over the paging zone through which the responding station last received a call.

**(5) Priority settings**

Sets whether paging calls or conversations should take precedence when these occur simultaneously.

**Paging priority:** When a call is received while receiving a paging call, the called station becomes busy and the paging call is gone through. Station keys cannot be used while receiving a paging call. (Paging response cannot be performed at a paging receiving station, either.)

**Conversation priority:** A paging call is not received when paged during a conversation or dialing operation. Station keys can be dialed even while receiving a paging call.

**(6) Calling station indication**

Select either "Call activated" or "Response activated" mode when performing the calling station indication function.

**Call activated:** The contact closes when the station initiates a call, and opens when the station terminates the call.

**Response activated:** The contact closes when the station responds to a call, and opens when the station terminates the call.

**(7) BGM input**

Set BGM to be heard at this IP station.

Select the multi interface unit's number and audio input number for each channel.

Select the unit's number and audio input number of the multi interface unit to which the BGM sound sources are connected.

**Step 3.** Click "Function Settings 2" tab to display the following setting screen.

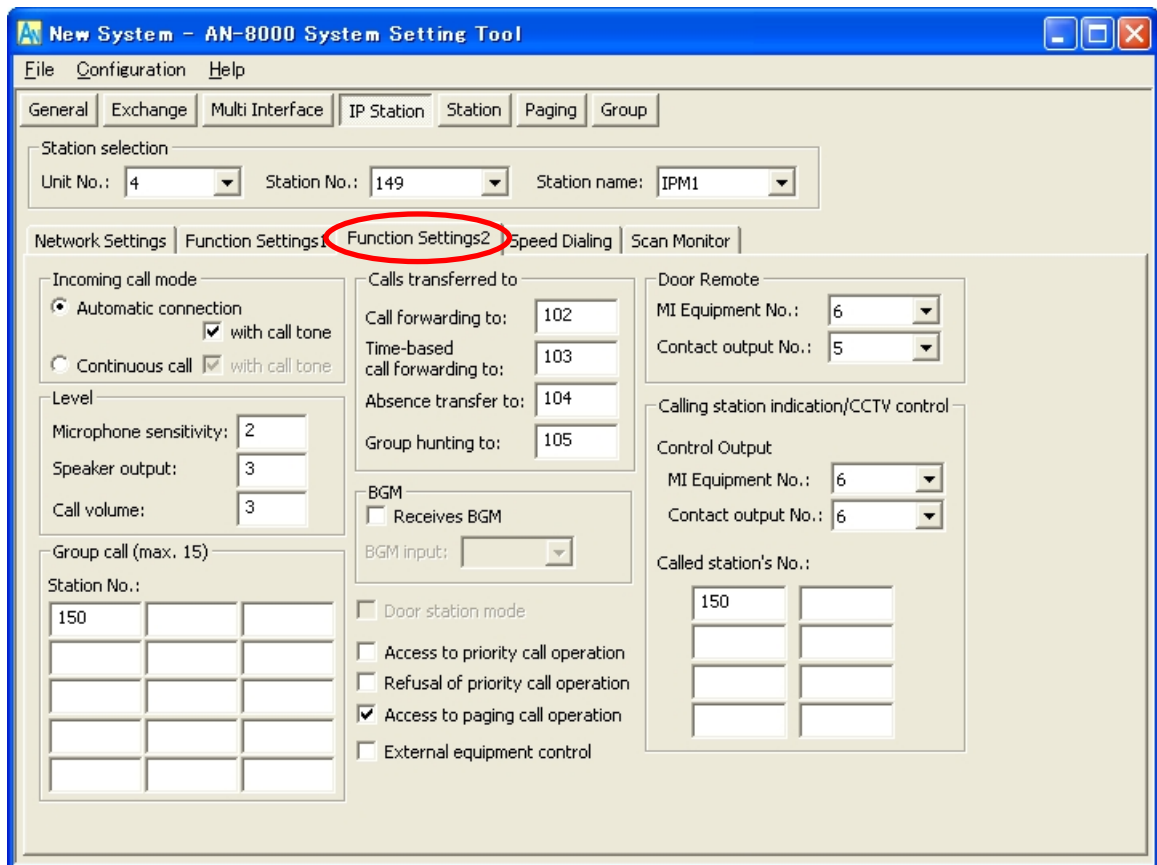

Available item differs depending on the type of IP stations.

**Step 4.** Set individual items.

**(1) Incoming call mode**

Call receiving mode can be selected either "Automatic connection" or "Continuous call". Call with a call tone or without a call tone can be set on both modes.  
The IP door station is fixed to "Automatic connection" mode.

**(2) Level**

- Microphone sensitivity: Station microphone sensitivity can be adjusted in three increments from 1 (minimum) to 3 (maximum). The default sensitivity is Level 2.
- Speaker output: Station speaker output level can be adjusted in five increments from 1 (minimum) to 5 (maximum). The default sensitivity is Level 3.
- Call volume: Station call volume can be adjusted in five increments from 1 (minimum) to 5 (maximum). The default sensitivity is Level 3.

**(3) Group call (max. 15) (IP master station only)**

Set a group of up to fifteen stations that will be called simultaneously when the IP station being set now is called. With this setting, even when a called station is busy, any registered station in the group can respond.

**(4) Calls transferred to (IP master station only)**

Set the station number to which each transfer is to be directed.  
Call forwarding receiving station can be set only when the call forwarding function is enabled. (Refer to p. 5-46)

**Note**

The station to be called via Multi interface unit cannot be programmed as a transfer destination station.

**(5) BGM**

Set whether the IP station receives BGM broadcasts. If receiving, place a checkmark and select the BGM channel number (1 – 8; Channel No.).

**(6) Door station mode (IP door station only)**

Set whether to operate the IP door station in door station mode\*.

\* The call tone sounds only once at the IP door station when the IP door station calls the pre-programmed master station. The call timeout and conversation timeout are set to 30 seconds each.

**(7) Access to priority call operation (IP master station only)**

Enables the IP station to initiate priority calls.

**(8) Refusal of priority call operation**

Enables the IP station to refuse priority calls from other stations.

**(9) Access to paging call operation (IP master station only)**

Enables or disables paging calls from the IP station.

**(10) External equipment control (IP master station only)**

Set whether the one-shot make output or make/break output is operated at the IP station.

**(11) Door Remote**

Set the Multi interface unit's unit number and contact output terminal number to be used for door remote control.

**(12) Calling station indication/CCTV control**

Control output No.: Set the Multi interface unit's unit number and contact output terminal number, which provide a make contact when the station is called.

Called station's No.: Provides a make contact when the station to be set here is called. Up to 8 stations can be set.

(Example)

The operation example illustrated below is based on the following settings:

Station No. (for IP station): 148

Control Output

MI Equipment No.: 5

Contact output No.: 6

Called station's No.: 149

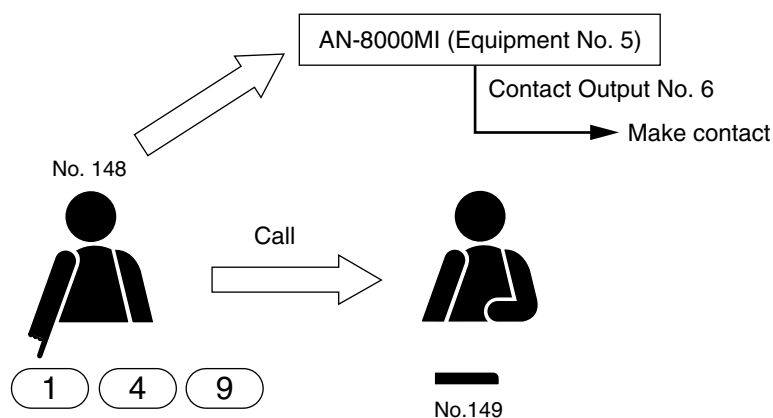

The Multi interface unit's (equipment No. 5) Contact No. 6 closes when the station No. 148 calls the station No. 149.

### 5.6.3. Speed dialing settings

**Step 1.** Click "Speed Dialing" tab to display the following setting screen.

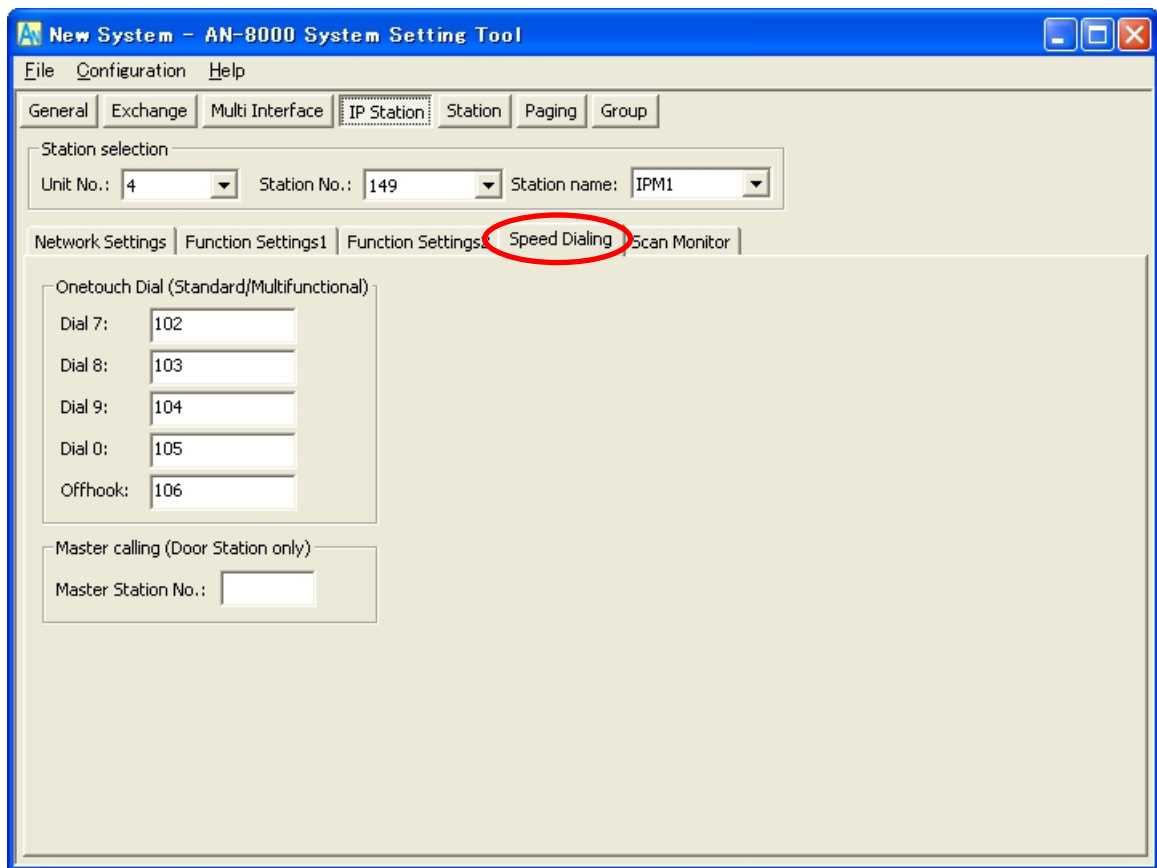

Available item differs depending on the type of stations.

**Step 2.** Enter the station numbers to be called for each of the one-touch dial keys ([7], [8], [9] and [0] keys) and the Off-Hook function. (IP master station only)

#### Tips

- Enter one-touch dialing programming using the Dial keys (12), Paging key, and/or Function key.
- Up to 20 digits dialing operation can be preset.
- To set keys other than the numerical keys listed above for speed dialing, enter these as follows:
 

[ # / ▲ ] key	: #
[ * / ▼ ] key	: *
Paging key	: P
Function key	: F

**Step 3.** Enter the master station number to be called when the door station's call button is pressed. (IP door station only)

#### 5.6.4. Scan Monitor settings (IP master station only)

**Step 1.** Click "Scan Monitor" tab to display the following setting screen.

**New System - AN-8000 System Setting Tool**

File Configuration Help

General Exchange Multi Interface **IP Station** Station Paging Group

Station selection  
 Unit No.: 4 Station No.: 149 Station name: IPM1

Network Settings Function Settings1 Function Settings2 Speed Dialing **Scan Monitor**

Scan monitor sequencing time (sec): 3

Scan monitor group (can be monitored in numerical sequence. Enter station No.)

Group 1				Group 2											
1.	102	2.	103	3.	104	4.	105	1.	106	2.	107	3.	108	4.	
5.		6.		7.		8.		5.		6.		7.		8.	
9.		10.		11.		12.		9.		10.		11.		12.	
13.		14.		15.		16.		13.		14.		15.		16.	

Group 3				Group 4											
1.	109	2.	110	3.	111	4.	112	1.	114	2.	115	3.	116	4.	
5.	113	6.		7.		8.		5.		6.		7.		8.	
9.		10.		11.		12.		9.		10.		11.		12.	
13.		14.		15.		16.		13.		14.		15.		16.	

**Step 2.** Set the scan monitor sequencing time in 1-second units from 1 to 10 seconds.

**Step 3.** Set the group of stations to be monitored.  
 Input the number of station to be monitored in the order of monitoring.

## 5.7. Setting Stations Connected to the Exchange

Click "Station" to select the station to be set.

Choose the number of the exchange, line number, station number or station name from the list.

Station selection

Exchange No.: 1    Station No.: 101    Station name: sta1-01

Line No.: 1

### (1) Exchange No.

Select the equipment number of the exchange to which the station is connected.

### (3) Station No.

Select the station number.

### (2) Line No.

Select the number of the line to which the station is connected.

### (4) Station name

Select the station name.

### 5.7.1. Function settings

**Step 1.** Click "Function Settings" tab to display the following setting screen.

New System - AN-8000 System Setting Tool

File Configuration Help

General Exchange Multi Interface IP Station Station Paging Group

Station selection

Exchange No.: 1    Station No.: 101    Station name: sta1-1

Line No.: 1

Function Settings Speed Dialing Scan Monitor

Incoming call mode

Automatic connection  with call tone

Continuous call  with call tone

Level

Microphone sensitivity: 2

Speaker output: 3

Call volume: 3

Group call (max. 15)

Station No.:

102	103	104
105	106	107
108	109	

Calls transferred to

Call forwarding to: 102

Time-based call forwarding to: 103

Absence transfer to: 104

Group hunting to: 105

BGM

Receives BGM

BGM input: 1

Door station mode

Access to priority call operation

Refusal of priority call operation

Access to paging call operation

External equipment control

Door Remote

MI Equipment No.: 6

Contact output No.: 4

Calling station indication/CCTV control

Control Output

MI Equipment No.: 6

Contact output No.: 3

Called station's No.:

105	106
107	

Available item differs depending on the type of stations.

**Step 2.** Set individual items.

**(1) Incoming call mode**

Call receiving mode can be selected either "Automatic Connection" or "Continuous Call". Call with a call tone or without a call tone can be set on both modes.

The door station is fixed to "Automatic connection" mode.

**(2) Level**

**Microphone sensitivity:** Station microphone sensitivity can be adjusted in three increments from 1 (minimum) to 3 (maximum). The default sensitivity is Level 2.

**Speaker output:** Station speaker output level can be adjusted in five increments from 1 (minimum) to 5 (maximum). The default sensitivity is Level 3.

**Call volume:** Station call volume can be adjusted in five increments from 1 (minimum) to 5 (maximum). The default sensitivity is Level 3.

**(3) Group call (max. 15) (Master station only)**

Set a group of up to fifteen stations that will be called simultaneously when the station being set now is called. With this setting, even when a called station is busy, any registered station in the group can respond.

**Note**

The station to be called via Multi interface unit cannot be programmed as a transfer destination station.

**(4) Calls transferred to (Master station only)**

Set the station number to which each transfer is to be directed.

Call forwarding receiving station can be set only when the call forwarding function of the Exchange is enabled. (Refer to [p. 5-29](#))

**Note**

The station to be called via Multi interface unit cannot be programmed as a transfer destination station.

**(5) BGM**

Set whether the station receives BGM broadcasts. If receiving, place a checkmark and select the BGM channel number (1 – 8; Channel).

**(6) Door station mode (Door station only)**

Set whether to operate the door station in door station mode\*.

\* The call tone sounds only once at the door station when the door station calls the pre-programmed master station. The call timeout and conversation timeout are set to 30 seconds each.

**(7) Access to priority call operation (Master station only)**

Enables the station to initiate priority calls.

**(8) Refusal of priority call operation**

Enables the station to refuse priority calls from other stations.

**(9) Access to paging call operation (Master station only)**

Enables or disables paging calls from the station.

**(10) External equipment control (Master station only)**

Set whether the one-shot make output or make/break output is operated at the station.

**(11) Door Remote**

Set the Multi interface unit's unit number and contact output terminal number to be used for door remote control.



**(12) Calling station indication/CCTV control**

Control output No.: Set the Multi interface unit's unit number and contact output terminal number, which provide a make signal when the station is called.

Called station's No.: Provides a make contact when the station to be set here is called. Up to 8 stations can be set.

(Example)

The operation example illustrated below is based on the following settings:

Station No.: 101

Control Output

MI Equipment No.: 5

Contact output No.: 3

Called station's No.: 105

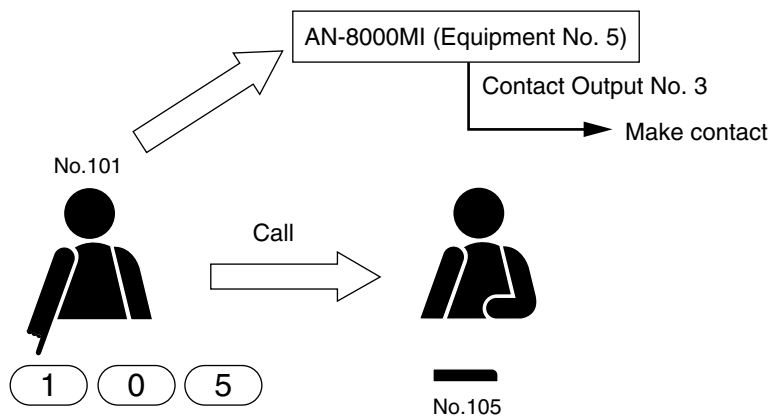

The Multi interface unit's (equipment No. 5) Contact No. 3 closes when the station No. 101 calls the station No. 105.

## 5.7.2. Speed dialing settings

**Step 1.** Click "Speed Dialing" tab to display the following setting screen.

Available item differs depending on the type of stations.

**Step 2.** Enter the station numbers to be called for each of the one-touch dial keys ([7], [8], [9] and [0] keys) and the Off-Hook function. (Master station only)

### Tips

- Enter one-touch dialing programming using the Dial keys (12), Paging key, and/or Function key.
- Up to 20 digits dialing operation can be preset.
- To set keys other than the numerical keys listed above for speed dialing, enter these as follows:
 

[ # / ▲ ] key	: #
[ * / ▼ ] key	: *
Paging key	: P
Function key	: F

**Step 3.** Enter the master station number to be called when the IP door station's call button is pressed. (Door station only)

5.7.3. Scan Monitor settings

Step 1. Click "Scan Monitor" tab to display the following setting screen.

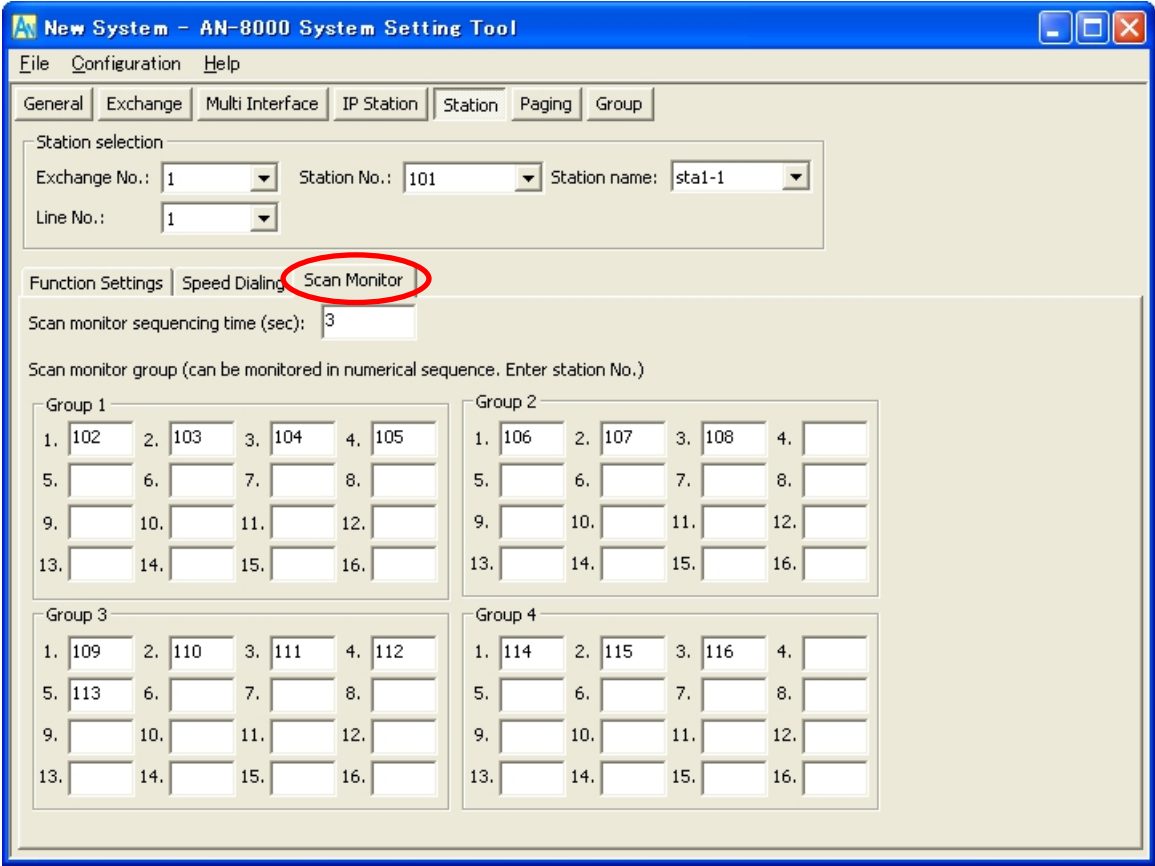

Step 2. Set the scan monitor sequencing time in 1-second units from 1 to 10 seconds.

Step 3. Set the group of stations to be monitored.  
Input the number of station to be monitored in the order of monitoring.

## 5.8. Paging Zone Settings

**Step 1.** Click "Paging" to display the following setting screen.

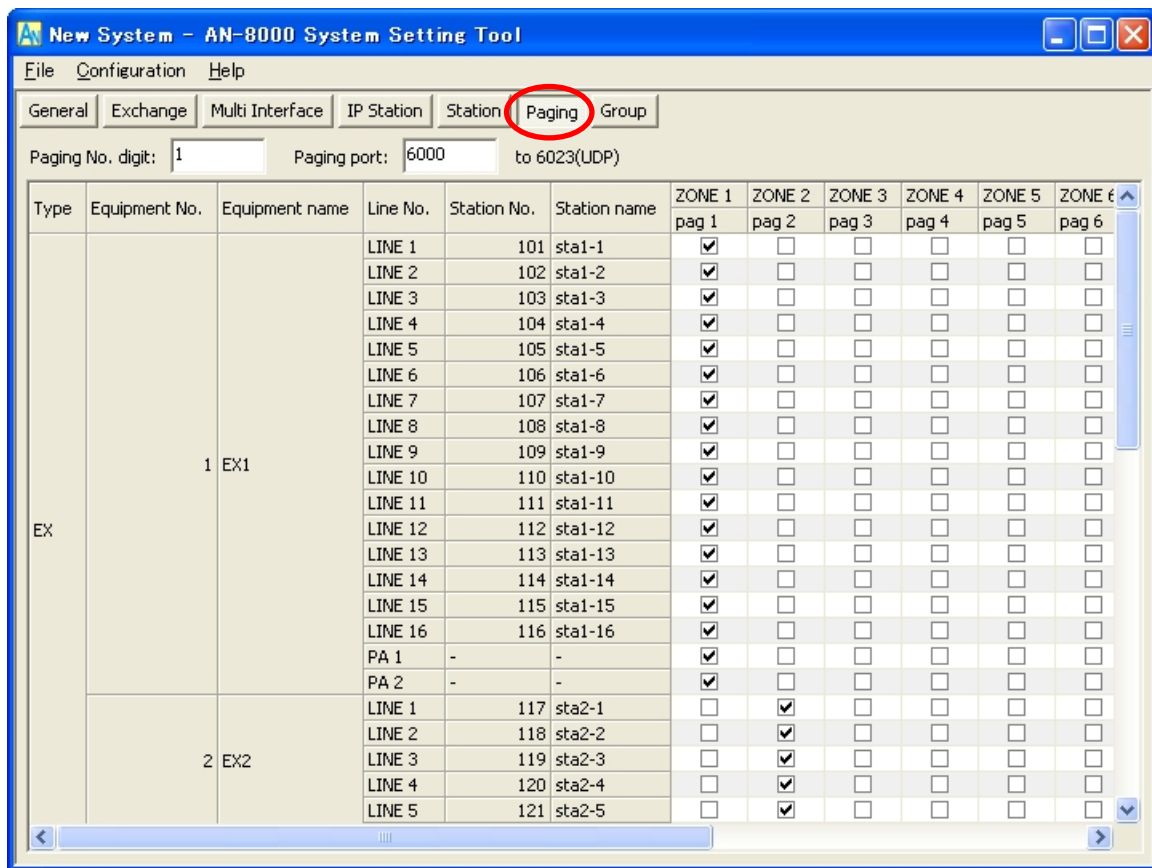

**Step 2.** Enter the paging number digit.

Enter the number 1, 2 or 3 in the input box for [Paging No. digit].

Zones are automatically indicated depending on which number is set. (For example, entering "1" displays zones 1 through 9 for editing, entering "2" displays zones 01 through 99 for editing, etc.) The maximum number of zones is 160.

**Step 3.** Enter the paging port number to be used.

Enter the start paging port number to be used in the system. The valid range is from 1 to 65535. The AN-8000 system uses (the number of Exchanges) x 4, (the number of Multi interface units) x 4 and (the number of IP Stations) x 4 consecutive ports starting with the start port.

### Note

Take care not to duplicate the number with the UDP port number set on [p. 5-24](#), [5-31](#), [5-42](#), and 15000 that is internally used.

**Step 4.** Enter a zone name.

Double-clicking the cell (paging 1 – ) located under the zone number allows the zone name to be edited. The zone name can be up to eight characters long.

**Step 5.** Select stations and external PA paging outputs included in each zone.

Click the desired cell to checkmark it.

## 5.9. Group Settings

**Step 1.** Click "Group" to set either Group Blocking or Remote Response group.

### 5.9.1. Group blocking settings

Stations can be divided into groups, to each of which call-to-other groups setting and paging zone setting can be assigned. Setting groups in this way allows a single system to be divided into several independent zones. Up to 31 groups can be preset.

#### [Group settings]

**Step 1.** Click "Group blocking group" tab to display the following screen.

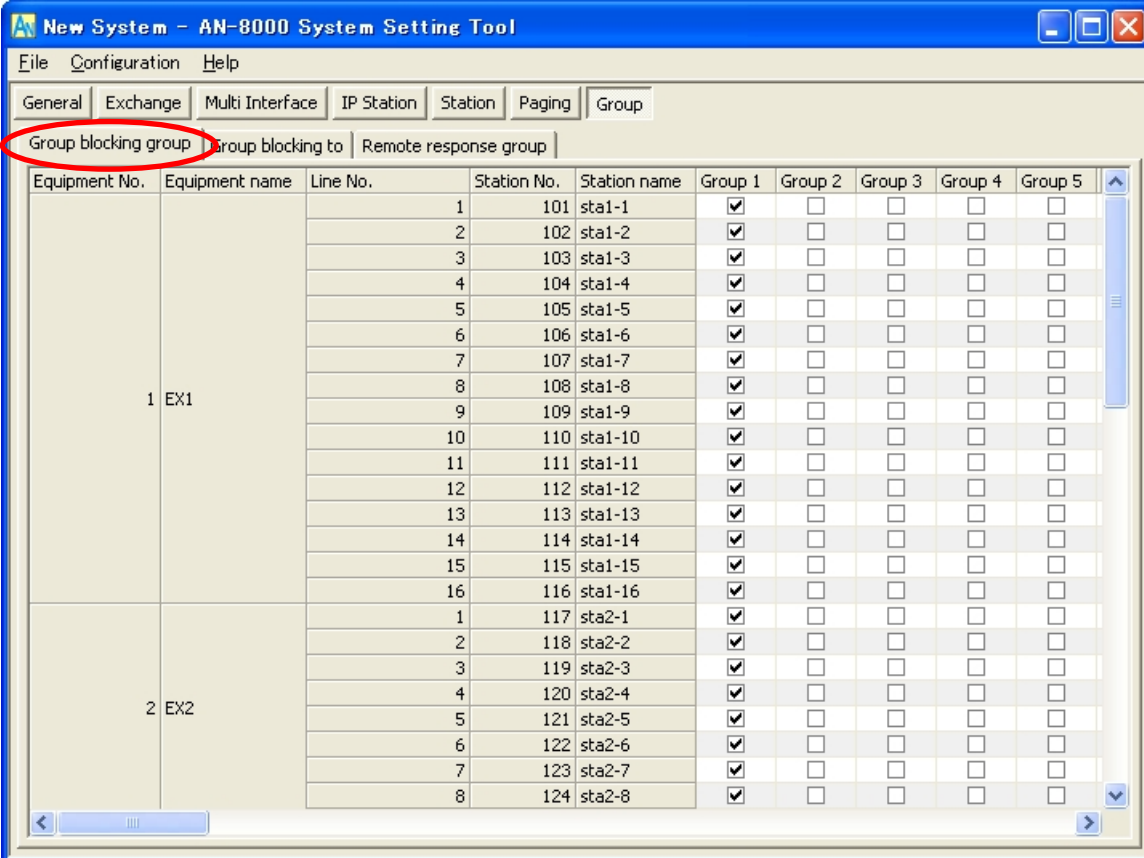

Equipment No.	Equipment name	Line No.	Station No.	Station name	Group 1	Group 2	Group 3	Group 4	Group 5
1	EX1	1	101	sta1-1	<input checked="" type="checkbox"/>	<input type="checkbox"/>	<input type="checkbox"/>	<input type="checkbox"/>	<input type="checkbox"/>
		2	102	sta1-2	<input checked="" type="checkbox"/>	<input type="checkbox"/>	<input type="checkbox"/>	<input type="checkbox"/>	<input type="checkbox"/>
		3	103	sta1-3	<input checked="" type="checkbox"/>	<input type="checkbox"/>	<input type="checkbox"/>	<input type="checkbox"/>	<input type="checkbox"/>
		4	104	sta1-4	<input checked="" type="checkbox"/>	<input type="checkbox"/>	<input type="checkbox"/>	<input type="checkbox"/>	<input type="checkbox"/>
		5	105	sta1-5	<input checked="" type="checkbox"/>	<input type="checkbox"/>	<input type="checkbox"/>	<input type="checkbox"/>	<input type="checkbox"/>
		6	106	sta1-6	<input checked="" type="checkbox"/>	<input type="checkbox"/>	<input type="checkbox"/>	<input type="checkbox"/>	<input type="checkbox"/>
		7	107	sta1-7	<input checked="" type="checkbox"/>	<input type="checkbox"/>	<input type="checkbox"/>	<input type="checkbox"/>	<input type="checkbox"/>
		8	108	sta1-8	<input checked="" type="checkbox"/>	<input type="checkbox"/>	<input type="checkbox"/>	<input type="checkbox"/>	<input type="checkbox"/>
		9	109	sta1-9	<input checked="" type="checkbox"/>	<input type="checkbox"/>	<input type="checkbox"/>	<input type="checkbox"/>	<input type="checkbox"/>
		10	110	sta1-10	<input checked="" type="checkbox"/>	<input type="checkbox"/>	<input type="checkbox"/>	<input type="checkbox"/>	<input type="checkbox"/>
		11	111	sta1-11	<input checked="" type="checkbox"/>	<input type="checkbox"/>	<input type="checkbox"/>	<input type="checkbox"/>	<input type="checkbox"/>
		12	112	sta1-12	<input checked="" type="checkbox"/>	<input type="checkbox"/>	<input type="checkbox"/>	<input type="checkbox"/>	<input type="checkbox"/>
		13	113	sta1-13	<input checked="" type="checkbox"/>	<input type="checkbox"/>	<input type="checkbox"/>	<input type="checkbox"/>	<input type="checkbox"/>
		14	114	sta1-14	<input checked="" type="checkbox"/>	<input type="checkbox"/>	<input type="checkbox"/>	<input type="checkbox"/>	<input type="checkbox"/>
		15	115	sta1-15	<input checked="" type="checkbox"/>	<input type="checkbox"/>	<input type="checkbox"/>	<input type="checkbox"/>	<input type="checkbox"/>
		2	EX2	1	117	sta2-1	<input checked="" type="checkbox"/>	<input type="checkbox"/>	<input type="checkbox"/>
2	118			sta2-2	<input checked="" type="checkbox"/>	<input type="checkbox"/>	<input type="checkbox"/>	<input type="checkbox"/>	<input type="checkbox"/>
3	119			sta2-3	<input checked="" type="checkbox"/>	<input type="checkbox"/>	<input type="checkbox"/>	<input type="checkbox"/>	<input type="checkbox"/>
4	120			sta2-4	<input checked="" type="checkbox"/>	<input type="checkbox"/>	<input type="checkbox"/>	<input type="checkbox"/>	<input type="checkbox"/>
5	121			sta2-5	<input checked="" type="checkbox"/>	<input type="checkbox"/>	<input type="checkbox"/>	<input type="checkbox"/>	<input type="checkbox"/>
6	122			sta2-6	<input checked="" type="checkbox"/>	<input type="checkbox"/>	<input type="checkbox"/>	<input type="checkbox"/>	<input type="checkbox"/>
7	123			sta2-7	<input checked="" type="checkbox"/>	<input type="checkbox"/>	<input type="checkbox"/>	<input type="checkbox"/>	<input type="checkbox"/>
8	124			sta2-8	<input checked="" type="checkbox"/>	<input type="checkbox"/>	<input type="checkbox"/>	<input type="checkbox"/>	<input type="checkbox"/>

**Step 2.** Select the station to be assigned to each group.

Click the cell for the station to be selected so that it becomes checkmarked.

**[Group blocking group settings]**

**Step 1.** Click "Group blocking to" tab to display the following screen.

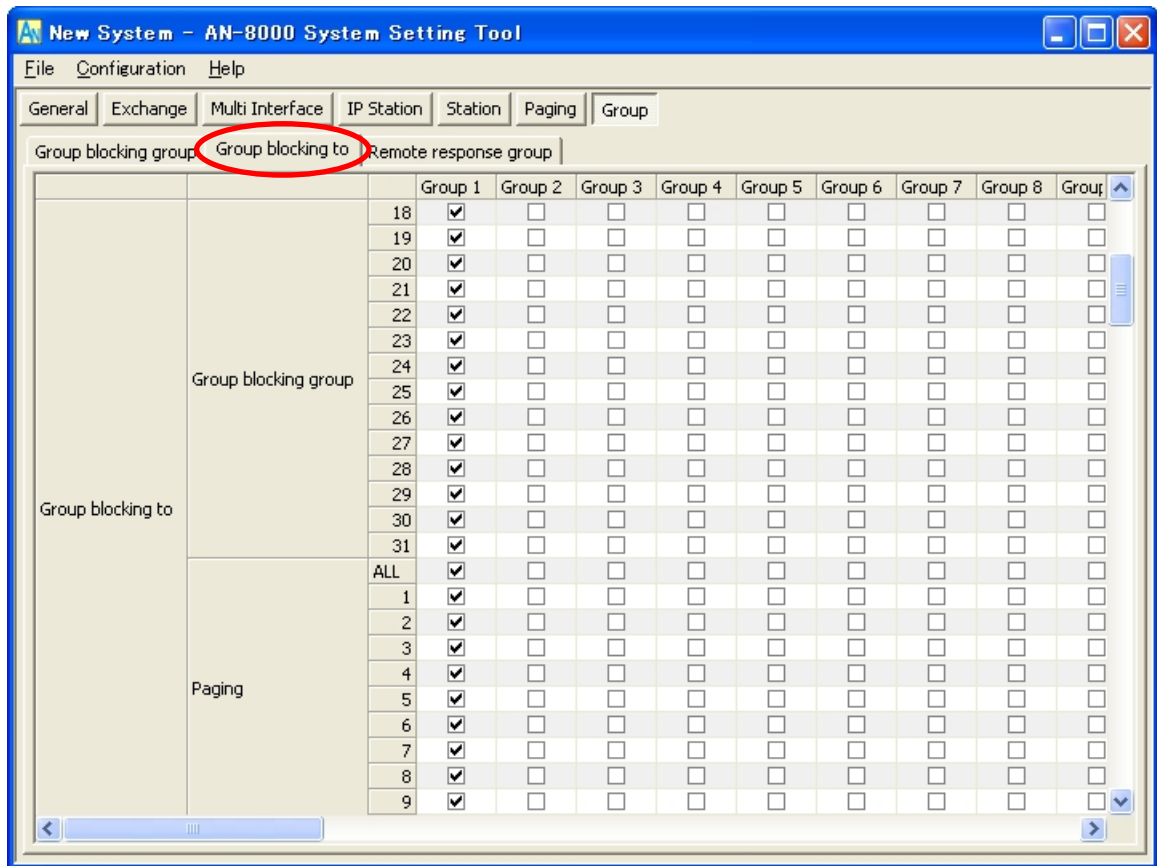
**Note**

The screen above is an example that Group 1 selects calling groups and paging zones.

**Step 2.** Tick the cell for the group to be selected to "Group blocking group" and "Paging."

**Note**

The paging zones desired to be enabled can be selected from "ALL" and individual zone numbers. Tick the checkbox of "ALL" to make all zones paging. Otherwise, ticking all checkboxes of zone numbers will not enable all zones paging.

### 5.9.2. Remote response group settings

Setting the remote response station group permits any station programmed for this function to respond to calls to other stations within the group.

Up to 16 stations can be preset.

#### [Creating new remote response group]

**Step 1.** Click "Remote response group" tab to display the following screen.

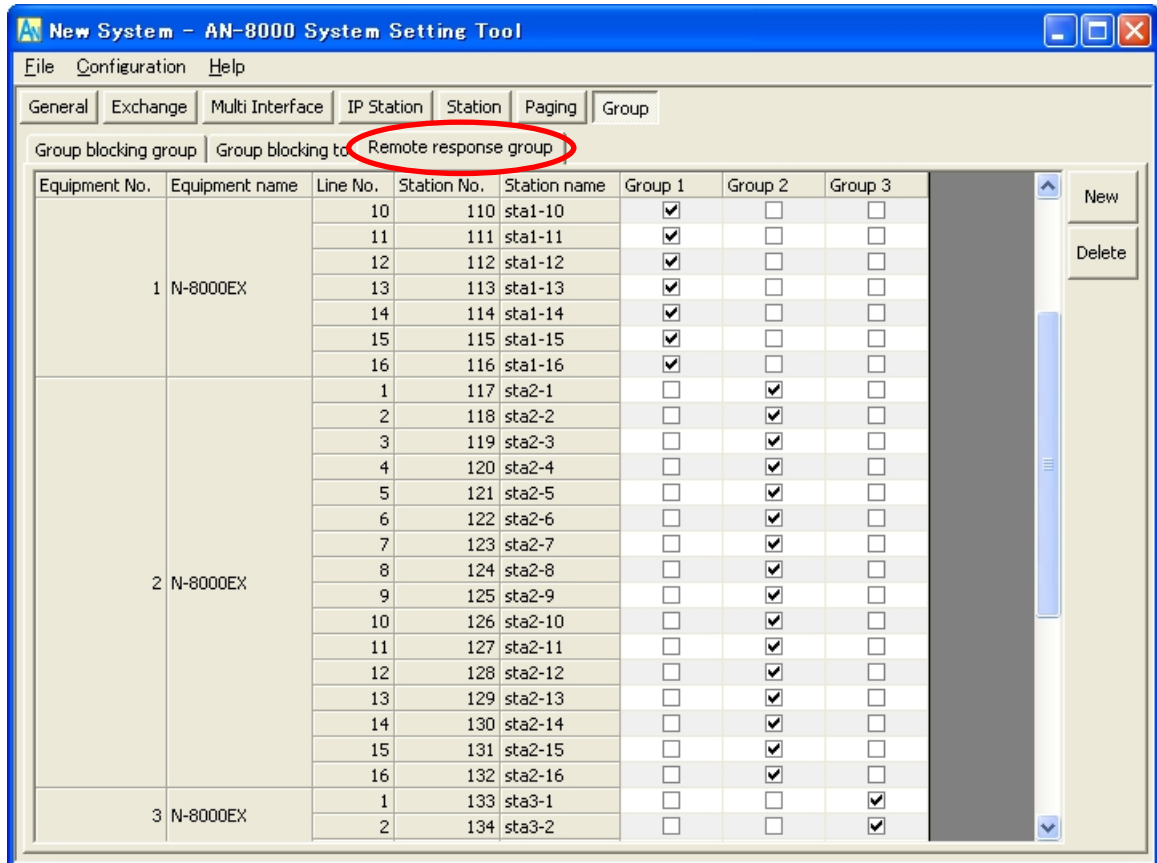

**Step 2.** Press "New" to create a remote response station group.

A new group column is added each time the button is pressed, permitting group registration of each station.

**Step 3.** Choose the stations to be configured into the group from the list.

Click the cell for the station to be selected so that it becomes checkmarked.

- Up to 16 stations can be programmed per group.
- A single station cannot be assigned to more than one group.

**[Editing remote response groups]**

**Step 1.** Click "Remote response group" tab to display the setting screen.

**Step 2.** Select the cell to be changed.

**[Deleting remote response groups]**

**Step 1.** Click "Remote response group" tab to display the setting screen.

**Step 2.** Select the cell for group title to be deleted (Group 1, Group 2 .....)  
The column for selected groups will be reverse-dimmed.

**Step 3.** Press [Delete].  
The column for selected groups will be deleted.



## 6. WHEN SETTINGS ARE COMPLETED

### 6.1. Saving Setting Contents to Files

Save the setting contents to a specified location.

Select [File → Save] from the menu bar.

By default, this location is a folder labeled with a system name within the AN-8000 software's install folder. For example if the system name is AN-8000, then the default save location would be "C:\Program Files\AIPHONE\AN-8000".

### 6.2. Uploading Settings

Uploads setting contents currently being edited.

Before uploading, be sure to save the settings contents to file as described above.

Select [Configuration → Upload] from the menu bar.

### 6.3. Downloading Settings

Reads the setting contents of equipment currently connected to the AN-8000 software.

Select [Configuration → Download] from the menu bar.

The settings data for equipment currently programmed into the system will be displayed on the system setting screen.

## 7. CHANGING THE PASSWORD

There are two passwords. One is a "system password" used with the AN-8000 software and browser; the other is a "station maintenance password" used by the AN-8000MS Multifunctional Master Station or the AN-8500MS IP Multifunctional Master Station.

### 7.1. Changing the System Password

**Step 1.** Click "Password Change" on the initial screen.

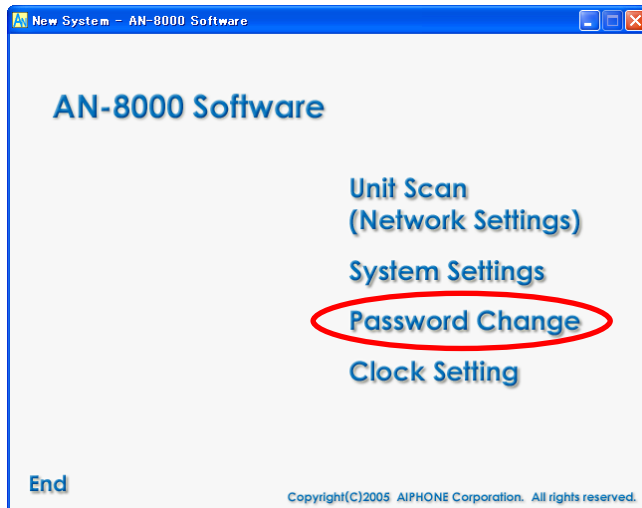

Dialog to change password is displayed.

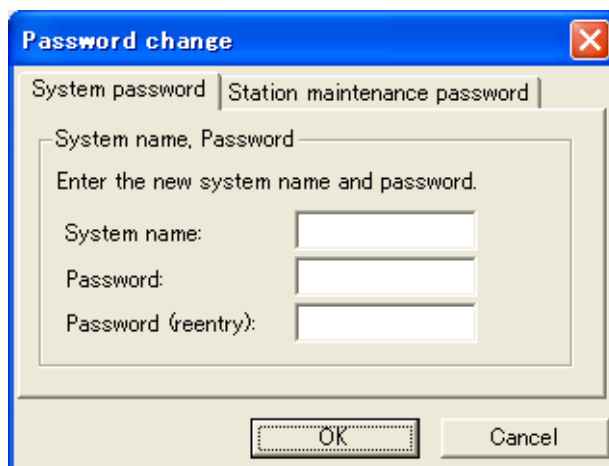

**Step 2.** In the [System name] entry box, enter a system name up to fifteen characters long after the change is made. This name is case-sensitive, and cannot include colons (:).

- Enter the original system name even if it is the same.
- Factory-preset: AN-8000

**Step 3.** In the [Password] entry box, enter a password up to fifteen characters long after the change is made. This name is case-sensitive, and cannot include colons (:).

- Enter the original password even if it is the same.
- Factory-preset: guest

**Step 4.** Enter the changed password entered in **Step 3** in the [Password (reentry)] entry box for confirmation.

**Step 5.** Press "OK".

**Note**

The status indicator located on the exchange, multi interface unit, or IP station remains lit during the update process. Do not restart the system or turn off the power while this light is on.

## 7.2. Changing the Station Maintenance Password

**Step 1.** Click "Password Change" on the initial screen to display "Password change" dialog.

**Password change**

System password | Station maintenance password

System name, Password

Enter the new system name and password.

System name:

Password:

Password (reentry):

OK Cancel

**Step 2.** Click "Station maintenance password" tab to display the Station maintenance password screen.

**Password change**

System password | Station maintenance password

Station maintenance password

Change password to be used when activating the maintenance function from the master station.

Old password:

New password:

New password (reentry):

OK Cancel

**Step 3.** Enter the old password in the [Old password] entry box.  
Factory-preset: 0000

**Step 4.** Enter a new password (four-digit number) in the [New password] entry box.

**Step 5.** Enter the changed password entered in **Step 4** in the [New password (reentry)] entry box for confirmation.

**Step 6.** Press "OK".

**Note**

The status indicator located on the exchange or IP station remains lit during the update process. Do not restart the system or turn off the power while this light is on.

## 8. SYSTEM CLOCK SETTINGS

The AN-8000 software program allows the clocks for all exchanges, multi interface units, and IP stations connected to the system to be set. To set exchange clocks individually (for example, if there is a time difference between exchanges), use either the browser (refer to p. 6-25), the AN-8000MS Multifunctional Master station, or the AN-8500MS IP Multifunctional Master station (refer to p. 7-7.)

- Synchronize the system clock with the PC clock through the following procedure. Make sure that the PC clock has been set with the correct time beforehand.

**Step 1.** Click "Clock Setting" on the initial screen.

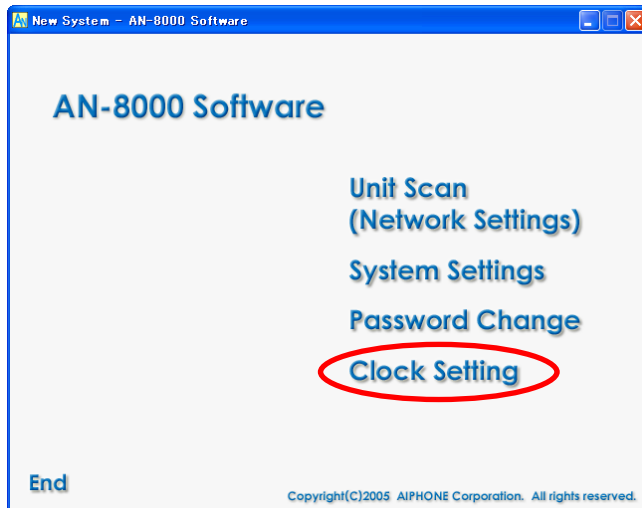

A clock-setting dialog is displayed, showing the PC's current time.

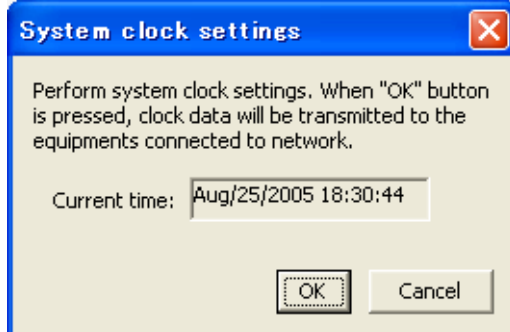

**Step 2.** Performs system clock settings.

Press "OK" to synchronize the clocks for all exchanges connected to the network with the PC clock.

# ***Chapter 6***

---

## ***SYSTEM SETTINGS USING THE BROWSER***

This chapter describes browser network settings, and system maintenance functions.

## 1. OUTLINE OF SETTINGS USING BROWSER

Network settings can be updated and maintenance functions controlled by connecting to the exchange, multi interface unit, or IP station via the PC's browser\*. If an exchange, multi interface unit, or IP station is not within range for the PC to administrate broadcast communications, use another PC to enable communications with the exchange, multi interface unit, or IP station.

\* Recommended Windows browser: Internet Explorer 6

### Notes

- Not all settings can be performed via the browser. After updating the network settings, add the exchange or multi interface unit manually using a PC installed with the AN-8000 Software, then perform the required settings. (refer to [p. 4-12](#) and [p. 5-17](#).)
- In the factory settings, the same IP address may be duplicated or the PC and the exchange, multi interface unit, or IP station may not be set to the same network. When using the browser to perform network settings, either connect only one exchange, multi interface unit, or IP station within the same network or disconnect the equipment and the PC to be set from the network, and connect them directly using an Ethernet crossing cable.
- CAUTION: If the power supply is shut off during setting change, this may cause a system failure.
- Updated settings become valid only after the equipment is restarted. Be sure to restart the equipment if settings are changed. Conversations and paging currently in progress will be temporarily interrupted while the equipment restarts.

## 2. MENU ITEMS

Menu	Network Setting (refer to <a href="#">p. 6-5</a> )	Changes the IP address, subnet mask, and default gateway of the exchange, multi interface unit, or IP station connected to the PC.
	Operation Status (refer to <a href="#">p. 6-6</a> )	Displays operation status.
	Line Status (refer to <a href="#">p. 6-12</a> )	This setting is applicable to the exchange only. Displays the line status.
	Network Status (refer to <a href="#">p. 6-14</a> )	Displays the connection status for all exchanges, multi interface units, or IP stations within the system.
	Operation Log (refer to <a href="#">p. 6-15</a> )	Displays exchange, multi interface unit, or IP station operation logs.
	Stream Log (refer to <a href="#">p. 6-17</a> )	Displays a log of the IP network's audio communications.
	System Management (refer to <a href="#">p. 6-20</a> )	Used to change passwords and handle uploads and downloads of settings files.

### Note

This menu is used to maintain exchanges, multi interface units, or IP stations for which system and function settings have been completed by means of the AN-8000 software.

### 3. DISPLAYING THE MENU SCREEN

#### Note

Perform the PC's network setting in advance to allow the PC to communicate with Exchanges, Multi interface units, and IP stations.

The user authentication screen will not be displayed unless the PC's network setting completed.

**Step 1.** Start the browser and enter the URL.

- Exchanges or multi interface units are shipped from the factory with the IP address set to "192.168.1.1" and the Web server port number set to "80." When the Web server port number is "80," the port number description after the colon (:) can be omitted.

URL	Example
http://IP address:Web server port number/index-e.htm	http://192.168.1.1/index-e.htm

The user authentication screen appears.

#### Notes

- The screen below is an example for the AN-8000EX.
- This screen will look slightly different depending on the browser being used.

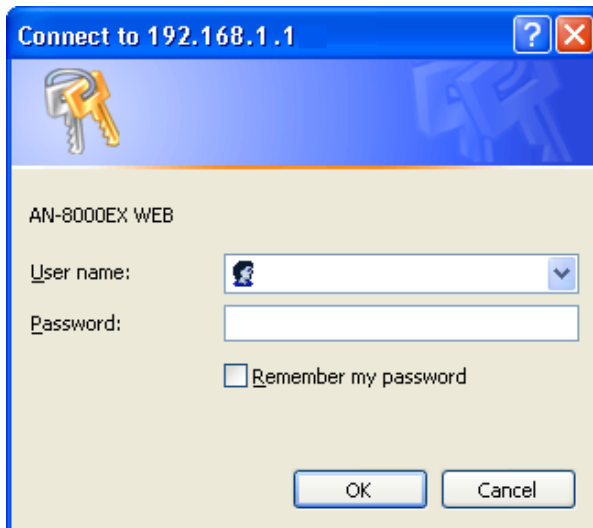

**Step 2.** Enter the user name (case-sensitive) and the password, then press the "OK" button. Enter the user name programmed to the AN-8000EX, AN-8000MI, AN-8500MS, or AN-8540DS.

The system name is factory-preset to "AN-8000" and the password to "guest."  
Refer to [p. 6-22](#) for information on how to change the system name and password.

The setting menu screen is displayed once you have entered the correct user name and the password. The screen below is an example for the AN-8000EX.

**AN-8000EX**  
Installation  
Setup

**Menu**

- [TOP](#)
- [Network Setting](#)
- [Operation Status](#)
- [Line Status](#)
- [Network Status](#)
- [Operation Log](#)
- [Stream Log](#)
- [System Management](#)

**AN-8000EX**

Unit Name	AN8000EX
IP Address	192.168.1.1
Subnet Mask	255.255.0.0
Default Gateway	0.0.0.0
MAC Address	00 - 05 - F9 - FF - 00 - 00

**AIPHONE®**

#### Note

Use the menu located on the left of the screen to display each setting screen. These screens will not be displayed properly using the browser's "Back" or "Forward" buttons.



## 4. NETWORK SETTING

Click "Network Setting" on the menu on the left of the screen.  
The screen below is an example for the AN-8000EX.

**AN-8000EX**  
**Installation Setup**

**Menu**  
[TOP](#)  
[Network Setting](#)  
[Operation Status](#)  
[Line Status](#)  
[Network Status](#)  
[Operation Log](#)  
[Stream Log](#)  
[System Management](#)

**Network Setting**

IP Address	192	168	1	1
Subnet Mask	255	255	255	0
Default Gateway	0	0	0	0
MAC Address	00-05-F9-FF-00-00			
Web server Port No.	80			
Unit Name	AN8000EX			

**AIPHONE®**

- (1) **IP Address**  
Enter the IP address of the Exchange, Multi interface unit, or IP station. (factory-preset: 192.168.1.1)
- (2) **Subnet Mask**  
Set the subnet mask. (factory-preset: 255.255.255.0)
- (3) **Default Gateway**  
Set this gateway if using equipment outside the assigned subnet. (factory-preset: 0.0.0.0)
- (4) **Web server Port No.**  
Enter the Web server port No.  
The valid range is from 1 to 65535. (factory-preset: 80)
- (5) **Unit Name**  
Enter the name of equipment up to 8 characters long.

**(6) Save button**

Write set data into the settings file in the equipment.

**Notes**

- The status indicator located on the equipment remains lit during the write process. Do not restart the system or turn off the power while this light is on.
- Changed network settings are not immediately updated, and the new settings take effect only after the exchange, multi interface unit, or IP station has been restarted. Restart the exchange, multi interface unit, or IP station by pressing the restart button that appears at the upper right of the screen whenever settings have been changed.

**5. OPERATION STATUS DISPLAY**

Click Operation Status on the menu on the left side of the screen.

**5.1. AN-8000EX**
**[Operation buttons]****(1) Refresh**

Updates status data for speech path, line, and contact.

**(2) Line No. and Terminal No. buttons**

Used to display line numbers or station numbers for each station.

**[Link status]**

Displays the exchange's current link status. Pressing the Update button updates this data.

**(1) Link No.**

Speech path numbers.

**(2) Calling Station**

Displays the number of the calling station.

**(3) Called Station**

Displays the number of the called station.

**(4) Station on hold**

Displays the number of the station on hold.

**(5) Status**

Displays the operating status of the speech path.

**5.2. AN-8000MI**

**AN-8000MI Installation Setup**

**Menu**

- [TOP](#)
- [Network Setting](#)
- [Operation Status](#)
- [Network Status](#)
- [Operation Log](#)
- [Stream Log](#)
- [System Management](#)

**Operation Status**

Jan/05/2004 01:55:47

Terminal No.  Line No.

**Link status**

Link No.	Calling Station	Called Station	Station on hold	Status
1	1000	90	-	Conversation
2	CH1	-	-	BGM
3	-	-	-	-
4	-	-	-	-

**Contact**

Contact No.	1	2	3	4	5	6	7	8
Input	ON	ON	OFF	OFF	OFF	OFF	OFF	OFF
Output	ON	ON	OFF	OFF	OFF	OFF	OFF	OFF

Contact No.	9	10	11	12	13	14	15	16
Input	OFF	OFF	OFF	OFF	OFF	OFF	OFF	OFF
Output	OFF	OFF	OFF	OFF	OFF	OFF	OFF	OFF

**AIPHONE®**

**[Operation buttons]**

**(1) Refresh**

Updates status data for speech path, line, and contact.

**(2) Terminal No. and Line No. buttons**

Used to display line numbers or station numbers for each station.

**[Link status]**

Displays the Multi interface unit's current link status. Pressing the Refresh button updates data.

**(1) Link No.**

Speech path numbers.

**(2) Calling Station**

Displays the number of the calling station.

**(3) Called Station**

Displays the number of the called station.

**(4) Station on hold**

Displays the number of the station on hold.

**(5) Status**

Displays the operating status of the speech path.

**[Contact]**

Displays the Multi interface unit's current contact status. Pressing the Refresh button updates data.

**(1) Contact No.**

Multi interface unit's contact input and output terminal numbers.

**(2) Input**

Current status of the contact input terminal is displayed.

**(3) Output**

Current status of the contact output terminal is displayed.

### 5.3. AN-8500MS

**AN-8500MS**  
Installation Setup

**Operation Status**  
Feb/10/2005 16:14:56

Terminal No.  Line No.

Calling Station	Called Station	Station on hold	Status
1000	1001	-	Conversation

Call receiving	Automatic transfer			Level		
	Call forwarding	Absence transfer	Group hunting	MIC	SP	Signal
-	-	-	-	3	3	3

**AIPHONE**

#### [Operation buttons]

##### (1) Refresh

Updates status data for speech path, line, and contact.

##### (2) Terminal No. and Line No. buttons

Used to display line number or station number.

#### [Operation status]

Displays the IP master station's current status of speech path and line. Pressing the Refresh button updates data.

##### (1) Calling Station

Displays the number of the calling station.

##### (2) Called Station

Displays the number of the called station.

##### (3) Station on hold

Displays the number of the station on hold.

##### (4) Status

Displays the operating status of the speech path.

**(5) Call receiving**

Displays the call tone mode of the IP master station.

**(6) Automatic transfer**

Displays the station number to which calls to the IP master station are to be automatically transferred.

**(7) Level**

Displays sound volume set for the IP master station. "Noise" is a measured ambient noise value. Indicator abbreviations are as follows:

- MIC: Microphone sensitivity
- SP: Speaker output volume
- Signal: Signal volume
- Noise: Noise level

## 5.4. AN-8540DS

**[Operation buttons]****(1) Refresh**

Updates status data for speech path, line, and contact.

**(2) Terminal No. and Line No. buttons**

Used to display line number or station number.

**[Operation status]**

Displays the IP door station's current status of speech path and line. Pressing the Refresh button updates data.

**(1) Calling Station**

Displays the number of the calling station.

**(2) Called Station**

Displays the number of the called station.

**(3) Station on hold**

Displays the number of the station on hold.

**(4) Status**

Displays the operating status of the speech path.

**(5) Level**

Displays sound volume set for the IP door station. "Noise" is a measured ambient noise value. Indicator abbreviations are as follows:

MIC: Microphone sensitivity

SP: Speaker output volume

Signal: Signal volume

Noise: Noise level

## 6. LINE STATUS INDICATION (Only for the Exchange)

Click "Line Status" on the menu on the left side of the screen.  
Displays information on line status and connected stations.

**AN-8000EX Installation Setup**

Sep/16/2004 13:44:33

**Line Status**

No.	Model No.	Status	Call receiving	Automatic transfer			Level				Ver.
				Call forwarding	Absence transfer	Group hunting	MIC	SP	Signal	Noise	
1	AN-8000MS	OK	Continuous	1000	-	-	2	2	2	300	1.00
2	AN-8000MS	OK	Continuous	1000	2000	3000	2	2	2	128	1.00
3	AN-8010MS	OK	Auto	4000	-	-	2	2	3	128	1.00
4	AN-8010MS	OK	Auto	4000	-	-	2	2	3	128	1.00
5	AN-8010MS	OK	Auto	4000	-	-	2	2	3	128	1.00
6	AN-8010MS	OK	Auto	4000	-	-	2	2	3	128	1.00
7	AN-8010MS	OK	Auto	4000	-	-	2	2	3	128	1.00
8	AN-8010MS	OK	Auto	4000	-	-	2	2	3	128	1.00
9	AN-8010MS	OK	Auto	4000	-	-	2	2	3	128	1.00
10	AN-8010MS	NG	Auto	4000	-	-	2	2	3	128	1.00

**AIPHONE®**

### [Operation buttons]

#### (1) Refresh

Updates status data for line, and station to the latest data.

### [Line Status]

#### (1) No

Line numbers

#### (2) Model No.

Displays the model number of the connected station.

#### (3) Status

Displays line status.



**(4) Call receiving**

Displays the call tone mode of the connected station.

**(5) Automatic transfer**

Displays the station number to which calls to the connected station are to be automatically transferred.

**(6) Level**

Displays sound volume set for the connected station. "Noise" is a measured ambient noise value. Indicator abbreviations are as follows:

- MIC: Microphone sensitivity
- SP: Speaker output volume
- Signal: Signal volume
- Noise: Noise level

**(7) Ver.**

Indicates the connected station's firmware version number.

## 7. NETWORK STATUS INDICATION

Click "Network Status" on the menu on the left side of the screen.

Connections between all exchanges, multi interface units, or IP stations and networks within the system can be confirmed. Connection status data is updated every two seconds, and if network connections are not achieved within ten seconds, the equipment is assumed to not be connected to the network.

The screen below is an example for the AN-8000EX.

The screenshot shows the AN-8000EX Network Status page. The browser title is "AN-8000EX - Microsoft Internet Explorer" and the address bar shows "http://192.168.1.1/index-e.htm". The page content includes a "Network Status" heading, a timestamp "Sep/16/2004 13:44:57", and two buttons: "Start" and "Abort". Below these is a table with 12 columns: "No.", "IP Address", "Status", "No.", "IP Address", "Status", "No.", "IP Address", "Status", "No.", "IP Address", "Status". The table contains 80 rows of data, with the first 20 rows showing "OK" status and the remaining 60 rows showing "-" status. The "Network Status" menu item in the left sidebar is circled in red.

No.	IP Address	Status	No.	IP Address	Status	No.	IP Address	Status	No.	IP Address	Status
1	192.168.1.1	OK	21	192.168.1.21	OK	41	192.168.1.41	-	61	192.168.1.61	-
2	192.168.1.2	OK	22	192.168.1.22	OK	42	192.168.1.42	-	62	192.168.1.62	-
3	192.168.1.3	OK	23	192.168.1.23	OK	43	192.168.1.43	-	63	192.168.1.63	-
4	192.168.1.4	OK	24	192.168.1.24	OK	44	192.168.1.44	-	64	192.168.1.64	-
5	192.168.1.5	OK	25	192.168.1.25	OK	45	192.168.1.45	-	65	192.168.1.65	-
6	192.168.1.6	OK	26	192.168.1.26	OK	46	192.168.1.46	-	66	192.168.1.66	-
7	192.168.1.7	OK	27	192.168.1.27	OK	47	192.168.1.47	-	67	192.168.1.67	-
8	192.168.1.8	OK	28	192.168.1.28	OK	48	192.168.1.48	-	68	192.168.1.68	-
9	192.168.1.9	OK	29	192.168.1.29	OK	49	192.168.1.49	-	69	192.168.1.69	-
10	192.168.1.10	OK	30	192.168.1.30	OK	50	192.168.1.50	-	70	192.168.1.70	-
11	192.168.1.11	OK	31	192.168.1.31	OK	51	192.168.1.51	-	71	192.168.1.71	-
12	192.168.1.12	OK	32	192.168.1.32	OK	52	192.168.1.52	-	72	192.168.1.72	-
13	192.168.1.13	OK	33	192.168.1.33	-	53	192.168.1.53	-	73	192.168.1.73	-
14	192.168.1.14	OK	34	192.168.1.34	-	54	192.168.1.54	-	74	192.168.1.74	-
15	192.168.1.15	OK	35	192.168.1.35	-	55	192.168.1.55	-	75	192.168.1.75	-
16	192.168.1.16	OK	36	192.168.1.36	-	56	192.168.1.56	-	76	192.168.1.76	-
17	192.168.1.17	OK	37	192.168.1.37	-	57	192.168.1.57	-	77	192.168.1.77	-
18	192.168.1.18	OK	38	192.168.1.38	-	58	192.168.1.58	-	78	192.168.1.78	-
19	192.168.1.19	OK	39	192.168.1.39	-	59	192.168.1.59	-	79	192.168.1.79	-
20	192.168.1.20	OK	40	192.168.1.40	-	60	192.168.1.60	-	80	192.168.1.80	-

### [Operation buttons]

#### (1) Start

Starts network connection verification.

#### (2) Abort

Aborts the network connection verification in progress.

**[Network status setting]****(1) No.**

Equipment number of the exchange, multi interface unit, or IP station.

**(2) IP Address**

IP address of the exchange, multi interface unit, or IP station.

**(3) Status**

"OK" is displayed when the unit connection is established.

**8. OPERATION LOG**

Click "Operation Log" on the menu on the left side of the screen.

The operation log displays the equipment's operating records. Up to 1,000 events can be stored.

The screen below is an example for the AN-8000EX.

**AN-8000EX**  
**Installation**  
**Setup**

**Menu**

- [TOP](#)
- [Network Setting](#)
- [Operation Status](#)
- [Line Status](#)
- [Network Status](#)
- [Operation Log](#)
- [Stream Log](#)
- [System Management](#)

**Operation Log**

Sep/16/2004 13:45:36

Log Save Latest Prev. page Next Page Number Indication Detail Indication

page 1

Time	Category	Contents	Line1	Line2	Line3
Sep/16/2004 13:39:24	System	Master clock mode	-	-	-
Sep/16/2004 13:39:15	System	System start	-	-	-
Sep/16/2004 13:39:08	System	Restart	-	-	-
Sep/16/2004 13:38:46	System	Firmware update start	-	-	-
Sep/16/2004 13:26:34	System	Master clock mode	-	-	-
Sep/16/2004 13:26:25	System	System start	-	-	-
Sep/16/2004 13:26:17	System	Restart	-	-	-
Sep/16/2004 13:26:13	System	Setting update start	-	-	-
Sep/16/2004 13:17:42	System	Master clock mode	-	-	-
Sep/16/2004 13:17:33	System	System start	-	-	-
Sep/16/2004 13:17:26	System	Restart	-	-	-
Sep/16/2004 13:17:05	System	Firmware update start	-	-	-
Sep/16/2004 13:14:33	System	Master clock mode	-	-	-
Sep/16/2004 13:14:24	System	System start	-	-	-
Sep/16/2004 13:14:17	System	Restart	-	-	-
Sep/16/2004 13:13:56	System	Firmware update start	-	-	-

**AIPHONE®**

Internet

**[Operation buttons]****(1) Log Save button**

Saves operation logs to a PC.

**(2) Latest button**

Updates operation logs.

**(3) Prev. Page button**

Returns the display to the previous page.

**(4) Next Page button**

Advances the display to the next page.

**(5) Number Indication button**

Switches the station display in the line column between "station number" and "line number." The display alternates between station and line numbers whenever this button is pressed.

**(6) Detail Indication button**

Adds any relevant error logs to the operation log display. The display alternates between operation logs and operation logs containing error logs each time this button is pressed.

**[Log items]**

**(1) Time**

Indicates the time that the event occurred.

**(2) Category**

Indicates the type of log.

Exchange Processing:	Line control data
System:	System data
Remote:	Control from PC

**(3) Contents**

Indicates event contents. Errors are indicated in red.

**(4) Line 1, Line 2 and Line 3**

Indicates the line on which an event occurred. Station and IP address numbers are displayed.

**Note**

If the indication "Firmware failed. Please contact our sales office." is displayed, the system is suffering a problem and could fail. In such cases, please contact the AIPHONE sales office immediately.

## 9. STREAM LOG

Click "Stream Log" on the menu on the left side of the screen.

The stream log is a history of voice communications (both conversations and paging) carried over the IP network. Displays can be switched between current and past histories. Up to 1,000 events can be stored.

### [Current stream screen]

The screen below is an example for the AN-8000EX.

**AN-8000EX**  
Installation  
Setup

**Stream Log**

Feb/19/2004 09:38

Log Save  Current  Past

---

**Current Stream**

Refresh

Time	Duration	Source	Link	Direction	Fs	Delay	Packets	Loss	Silence
Feb/19/2004 10:30:51	0:00:56	192.168.1.31	1	Transmission	16kHz	80ms	560	0	0
Feb/19/2004 10:30:51	0:00:56	192.168.1.31	1	Reception	16kHz	80ms	560	0	0
Feb/19/2004 10:31:21	0:00:36	192.168.1.32	2	Transmission	16kHz	80ms	360	0	0
Feb/19/2004 10:31:21	0:00:36	192.168.1.32	2	Reception	16kHz	80ms	360	10	10
Feb/19/2004 10:31:21	0:02:00	192.168.1.32	3	Transmission	16kHz	80ms	1000	0	0
Feb/19/2004 10:31:21	0:02:00	192.168.1.32	3	Transmission	16kHz	80ms	1000	0	0
Feb/19/2004 10:31:21	0:02:00	192.168.1.32	3	Transmission	16kHz	80ms	1000	0	0
Feb/19/2004 10:31:21	0:02:00	192.168.1.32	3	Transmission	16kHz	80ms	1000	0	0
Feb/19/2004 10:31:21	0:02:00	192.168.1.32	3	Transmission	16kHz	80ms	1000	0	0

**AIPHONE®**

### [Operation buttons]

#### (1) Log Save button

Saves stream logs to a PC.

#### (2) Current button and Past button

The Current button displays the current stream log; the Past button displays finished stream logs.

### [Current stream operation buttons]

#### (1) Refresh button

Updates stream logs.

**[Past stream screen]**

The screen below is an example for the AN-8000EX.

**AN-8000EX**  
Installation Setup

Menu  
[TOP](#)  
[Network Setting](#)  
[Operation Status](#)  
[Line Status](#)  
[Network Status](#)  
[Operation Log](#)  
[Stream Log](#)  
[System Management](#)

**Stream Log**

Feb/19/2004 09:38:16

Log Save  Current  Past

**Past Stream**

Refresh Prev. Page Next Page

page 1

Time	Duration	Source	Link	Direction	Fs	Delay	Packets	Loss	Silence
Feb/19/2004 10:30:51	0:00:09	192.168.1.31	1	Transmission	16kHz	80ms	147	0	0
Feb/19/2004 10:30:51	0:00:09	192.168.1.31	1	Reception	16kHz	80ms	147	20	20
Feb/19/2004 09:37:33	0:15:13	192.168.1.33	1	Transmission	16kHz	80ms	14385	0	0
Feb/19/2004 08:00:20	0:00:10	192.168.1.32	1	Transmission	16kHz	80ms	141	0	0
Feb/19/2004 07:37:33	0:15:13	192.168.1.33	1	Transmission	16kHz	80ms	14385	0	0
Feb/19/2004 06:00:20	0:00:10	192.168.1.32	1	Transmission	16kHz	80ms	141	0	0
Feb/19/2004 05:37:33	0:15:13	192.168.1.33	1	Transmission	16kHz	80ms	14385	0	0
Feb/18/2004 14:00:20	0:00:10	192.168.1.32	1	Transmission	16kHz	80ms	141	0	0
Feb/18/2004 13:37:33	0:15:13	192.168.1.33	1	Transmission	16kHz	80ms	14385	0	0
Feb/18/2004 12:00:20	0:00:10	192.168.1.32	1	Transmission	16kHz	80ms	141	0	0

**[Past stream operation buttons]**

- (1) **Refresh**  
Displays the last sixteen finished streams.
- (2) **Prev. Page button**  
Returns the display to the previous page.
- (3) **Next Page button**  
Advances the display to the next page.

**[Log items] (common to current and past stream logs)**

- (1) **Time**  
Time the stream began.
- (2) **Duration**  
Duration of the communication stream.
- (3) **Source**  
IP address of the exchange the station is connected to.

- (4) **Link**  
Speech path number.
- (5) **Direction**  
Sending or receiving.
- (6) **Fs**  
Sampling frequency, either 8 kHz or 16 kHz.
- (7) **Delay**  
Time between voice input and output.
- (8) **Packets**  
Number of packets transmitted or successfully received.
- (9) **Loss**  
Number of packets lost due to network failures, which is counted at the receiving end only.
- (10) **Silence**  
When voice output is reproduced as silence due to packet loss or late packet arrival (due to high network traffic), the number of packets in which silence data is embedded is counted at the receiving end.

## 10. SYSTEM MANAGEMENT

Click "System Management" on the menu on the left side of the screen.  
The screen below is an example for the AN-8000EX.

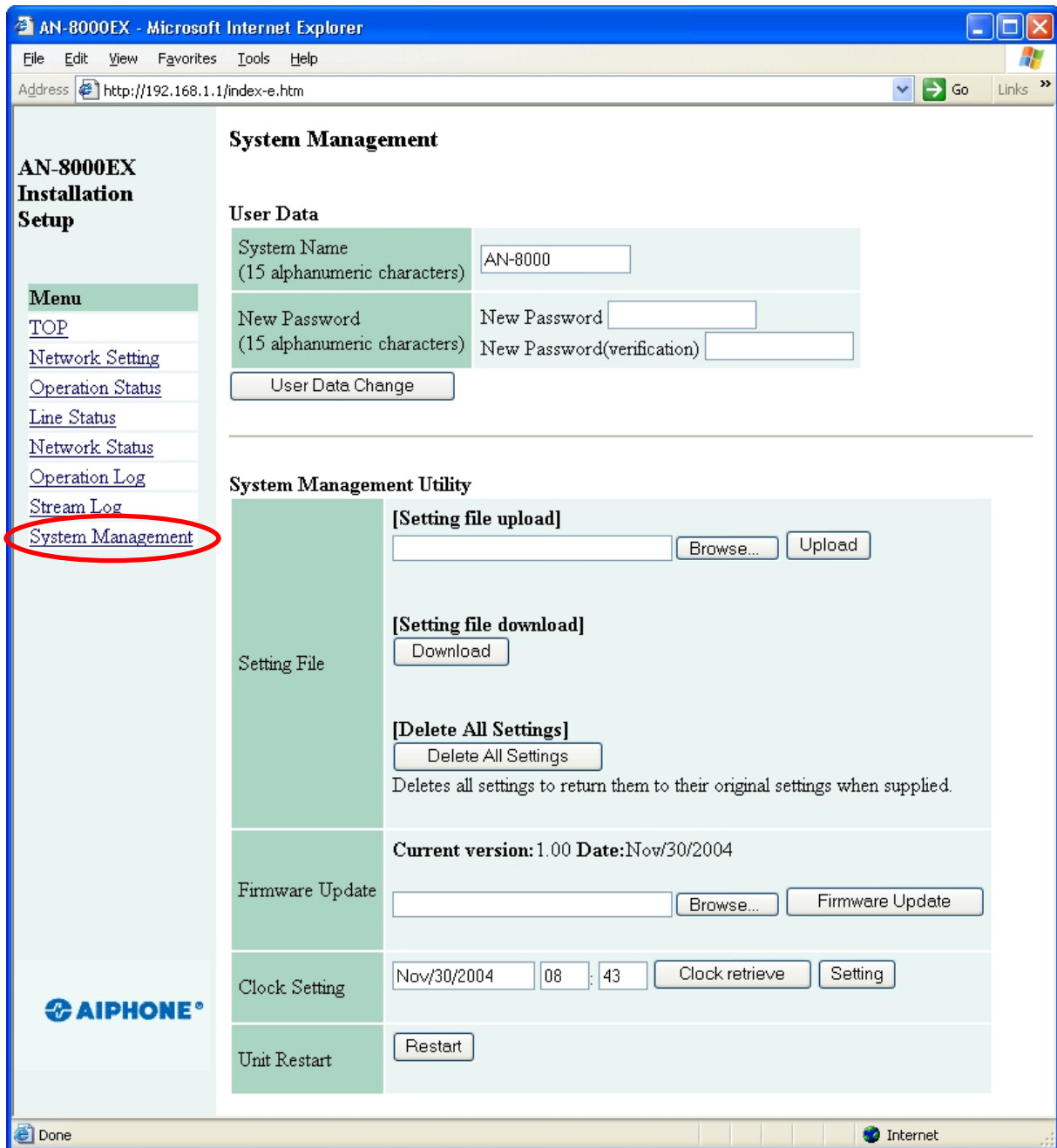

### [User Data]

The system name and password can be changed (refer to [p. 6-22](#)).

#### (1) System Name

Displays the user name entered on the user authentication screen when the browser was started (refer to [p. 6-3](#)).

#### (2) New Password

Enter a new password.

#### (3) New Password (verification)

Enter the same password again for confirmation.



**(4) User Data Change button**

Pressing this button registers the newly changed user data.

**([System Management Utility])**

**(1) Upload button**

Used to write backed-up settings files into the exchange, multi interface unit, or IP station connected to the PC. (refer to [p. 6-22](#)).

**(2) Browse button**

A file selection dialog appears.

**(3) Download button**

Saves the equipment's settings data (files) to the PC (refer to [p. 6-23](#)).

**(4) Delete All Settings button**

Deletes all settings and returns the exchange to its initial factory settings shown below.

IP address: 192.168.1.1

System name: AN-8000

Password: guest

Confirm other settings online using the AN-8000 software.

**(5) Firmware Update button**

Updates firmware (refer to [p. 6-24](#)).

Use the latest version of firmware.

**Tips**

- Please contact to the AIPHONE sales office to obtain the up-to-date version for firmware.
- The current version is displayed above the Firmware Update button.

**(6) Clock retrieve button**

Pressing this button displays the date and time of the connected PC's clock (refer to [p. 6-25](#)).

**(7) Setting button**

Used to set the equipment's clock (refer to [p. 6-25](#)).

**(8) Restart button**

Restarts the equipment.

**Note**

Never restart the equipment while changing settings files or performing a firmware update.

## 10.1. Changing System Names and Passwords

When adding an exchange, multi interface unit, or IP station, or initializing exchange, multi interface unit, or IP station settings, the system name and password can be changed remotely using the browser even from locations where the system settings PC is not available.

- Set the same system name and password as previously set using the AN-8000 software. The AN-8000 software cannot be used for centralized administration if different passwords have been used within the same system.

**Step 1.** Enter a new system name in "System Name box."

Enter a new system name up to fifteen characters long. This name is case-sensitive, and cannot include colons (:).

**Step 2.** Enter a new password in the "New Password" box.

Enter a new password up to fifteen characters long. This password is case-sensitive, and cannot include colons (:).

**Step 3.** Enter a new password that has been entered in step 2 in "New Password (confirmation)" box for confirmation.

**Step 4.** Press User Data Change button.

**Note**

The status indicator located on the exchange, multi interface unit, or IP station remains lit during update. Do not restart the system or turn off the power while this light is on.

## 10.2. Uploading Setting File

**Step 1.** Press "Browse..." button to display "File Selection" dialog.

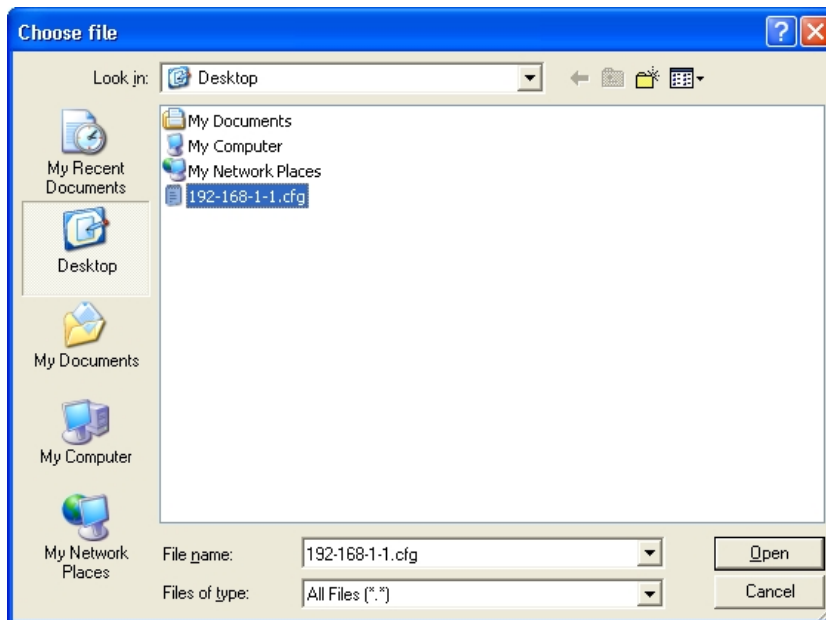

**Step 2.** Select "Backup file (extension cfg)", then press "Open" button.

**Step 3.** Press "Upload" button.

**Note**

The status indicator located on the exchange, multi interface unit, or IP station remains lit during update. Do not restart the system or turn off the power while this light is on.

### 10.3. Downloading Setting File

**Step 1.** Press "Download" button to display "File Download" dialog.

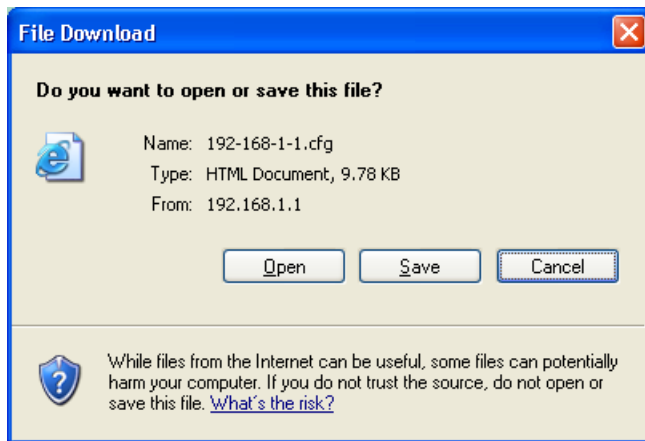

**Step 2.** Press "Save" button to display the dialog.

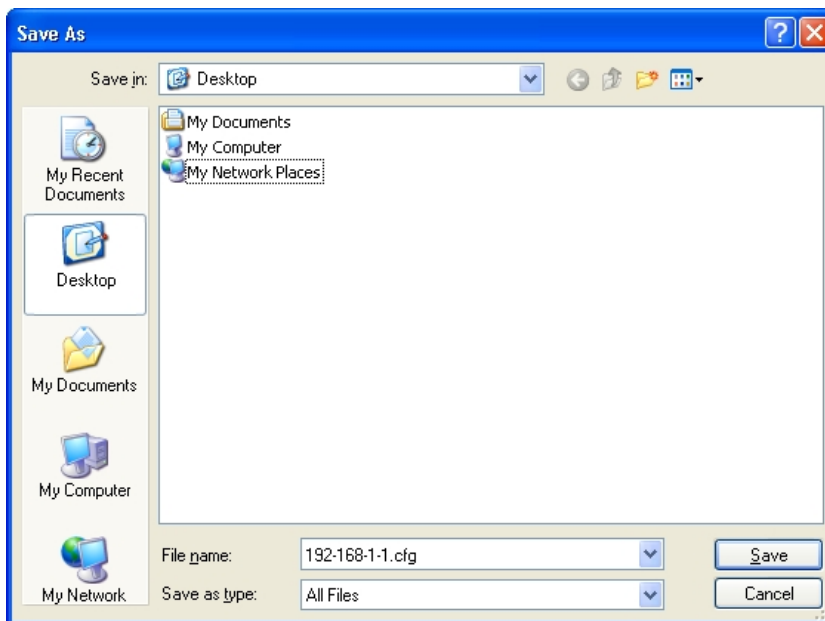

**Step 3.** Select saving location, then enter file name.

**Tip**

The file name is factory-preset to [IP address] .cfg.

**Step 4.** Select "All Files" in the file type box, then press "Save" button.

## 10.4. Updating Firmware

### Note

Updating the firmware may erase the set data (the settings reverts to the factory default settings) depending on the updated contents.

Before update, be sure to save the current setting file to the PC first.

After update completion, perform network settings, and change the system name and password, then upload the stored setting file using the AN-8000 Software program. Review the settings and correct them if changed.

**Step 1.** Press "Browse..." button to display "Choose file" dialog.

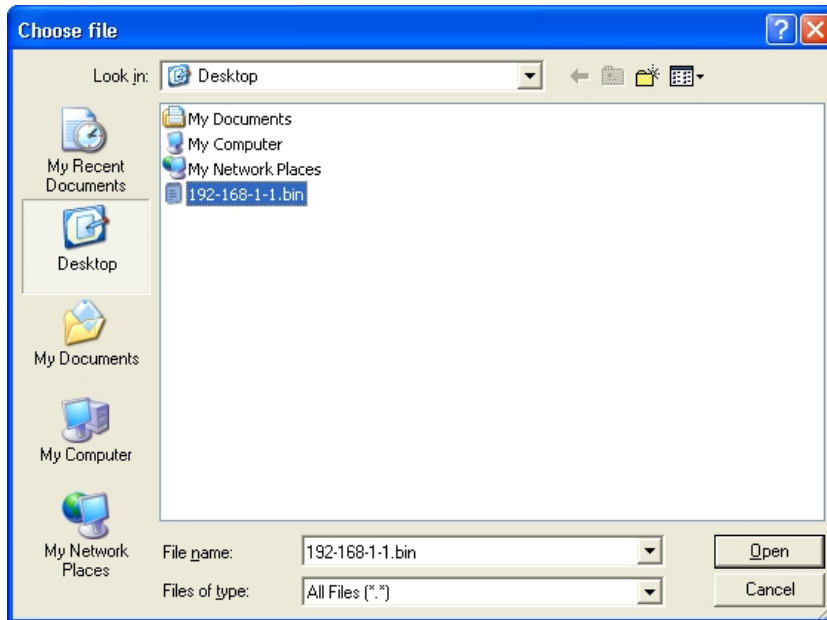

**Step 2.** Select the firmware (extension cfg), then press "Open" button.  
Use the latest version of firmware.

### Tips

- Please contact to the AIPHONE sales office to obtain the up-to-date version for firmware.
- The current firmware version can be confirmed on the browser's system management screen.

**Step 3.** Press "Firmware Update" button to start firmware updating.

### Note

The status indicator located on the exchange, multi interface unit, or IP station remains lit during update. Do not restart the system or turn off the power while this light is on.

## 10.5. Clock Settings

If there is a time difference between exchange, multi interface units, or IP stations connected to the system, each exchange's time can be adjusted individually. When the red indication "Clock not set." is displayed in the "Clock setting" box, this indicates that the clock has never been set in the past or the power has long been turned off. In such cases, perform clock settings.

### **Clock adjustment using the Clock Retrieve button**

The date and time of the exchange, multi interface unit, or IP station can be adjusted to those of the PC.

**Step 1.** Press "Clock retrieve" button.

**Step 2.** Press "Setting" button.

### **Clock adjustment using a PC**

Permits the time to be entered. It is impossible to change the date with this method.

**Step 1.** Move the cursor to the "hours" and "minutes" cells and enter the time in 24-hour formats.

**Step 2.** Press "Setting" button.

# ***Chapter 7***

---

## ***MULTIFUNCTIONAL STATION MENU SCREEN OPERATION (AN-8000MS/8500MS ONLY)***

This chapter describes the settings and displays available using the menu screen of the Multi-Functional Station and IP Multi-Functional Station.

## 1. KEYS USED FOR MENU SCREEN OPERATION

The following keys are used to operate the menu screen of the AN-8000MS Multifunctional Master Station and the AN-8500MS IP Multifunctional Master Station.

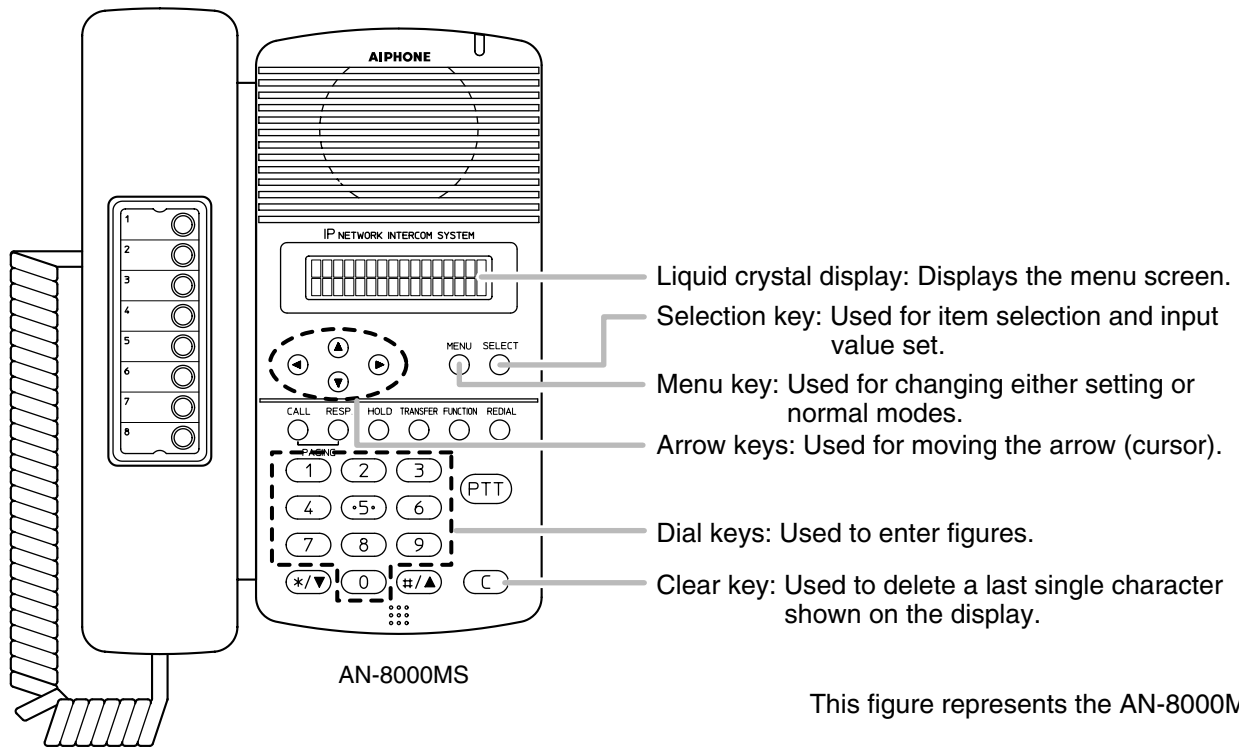

## 2. MENU ITEMS

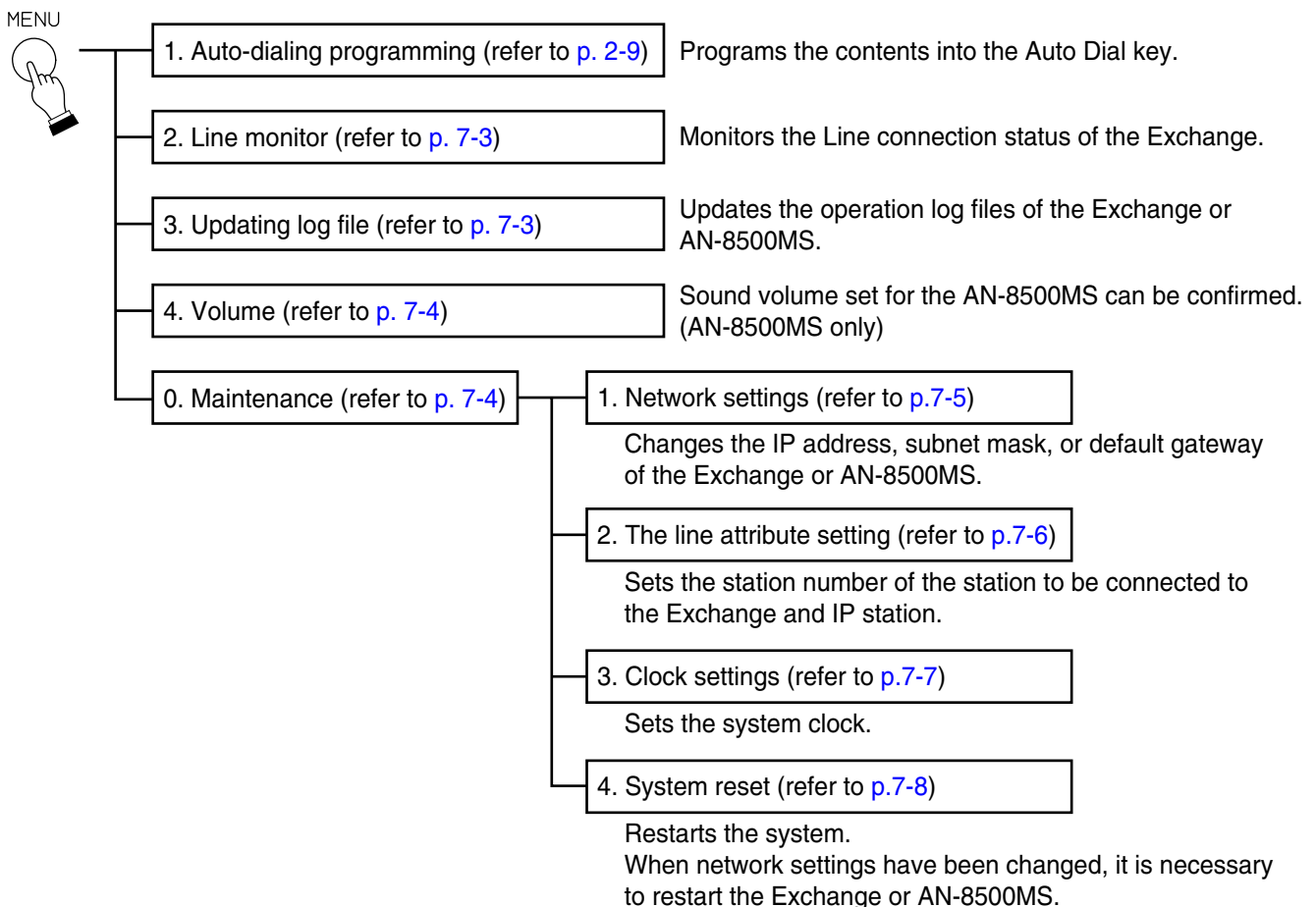

### 3. MONITORING LINE STATUS

Causes the station's LCD to display the connection status for all sixteen lines associated with the exchange to which the AN-8000MS is connected.

The AN-8500MS does not have the monitoring function.

**Step 1.** Press the Menu key to place the display in setting mode.



→1: Auto-dialing  
2: Line monitor

**Step 2.** Use the down arrow key or the [2] key to move the cursor to "2: Line monitor."



1: Auto-dialing  
→2: Line monitor

**Step 3.** Press the Select key to display the connection status for all sixteen lines. Lines are listed in order from left to right as Line 1, Line 2, and so on up to Line 16.



2: Line monitor  
000X000XX00FF000

Display symbol	Contents	Details
O	Connected (Normal)	Station is connected to the line and communications are being performed correctly between the exchange and station.
X	Unconnected	Station is not connected to the line or a wire is broken.
F	Connected (Abnormal)	Station is connected to the line, but communications are not being performed correctly.

"No Information" is displayed on the AN-8500MS's LCD.

**Step 4.** Press the Menu key to return the display to its normal standby mode.



10:08 AM  
2000

### 4. UPDATING LOG FILES

Update the file that stores the operation logs for the exchange or AN-8500MS\*.

Use this function when some malfunction has made it impossible to view the operation log via a PC (refer to p. 6-15, Browser Operation Log Display). Follow the procedures below to update the log file at the station, then restart the exchange.

\* Exchange when the station performing update is AN-8000MS, and the AN-8500MS itself when it is the AN-8500MS.

**Step 1.** Press the Menu key to place the display in setting mode.



→1: Auto-dialing  
2: Line monitor

**Step 2.** Use the down arrow key or the [3] key to move the cursor to "3: Log file."



2: Line monitor  
→3: Log file

**Step 3.** Press the Select key to update the log file of the exchange to which the station is connected or AN-8500MS.



3: Log file  
Updated

**Note**

The status indicator located on the exchange's front panel or AN-8500MS remains lit during the update process. Do not restart the system or turn off the power while this light is on.

**Step 4.** Press the Menu key to return the display to its normal standby mode.



10:08 AM  
2000



## 5. CONFIRMING THE SET SOUND VOLUME (AN-8500MS ONLY)

The microphone sensitivity and speaker output volume set for the AN-8500MS can be confirmed.

**Step 1.** Press the Menu key to place the display in setting mode.



→1: Auto-dialing  
2: Line monitor

**Step 2.** Use the down arrow key or the [4] key to move the cursor to "4: Volume."



3: Log file  
→4: Volume

**Step 3.** Press the Select key.

Both set levels for microphone sensitivity (MIC) and speaker output (SP) are displayed.

The MIC level is indicated in 3 steps from 1 (min.) to 3 (max.), and the SP level in 5 steps from 1 (min.) to 5 (max.).



4: Volume  
MIC: 2 SP: 3

**Step 4.** Press the Menu key to return the display to its normal standby mode.



10:08 AM  
2000

## 6. SYSTEM SETTINGS

Only a portion of system setting items can be set at the Multifunctional Station.

### 6.1. Entering Maintenance Screen

**Step 1.** Press the Menu key to place the display in setting mode.



→1: Auto-dialing  
2: Line monitor

**Step 2.** Use the up or down arrow keys or the [0] key to move the cursor to "0: Maintenance."



3: Log file  
→0: Maintenance

**Step 3.** Press the Select key to display the password entry screen.



Password  
→=\*\*\*\*

**Step 4.** Enter 4-digit-password by pressing dial keys, then press the Select key.

The default factory setting is 0000. It can be changed using the AN-8000 Software. (Refer to [p. 5-64.](#))

**[Example]**

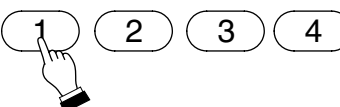

After password has been entered correctly, system setting screen is displayed.



→1: Network set  
2: LineAttribute

## 6.2. Network Settings

It is possible to change the IP address, subnet mask, and default gateway of the exchange or AN-8500MS\*.

\* Exchange when the station performing setting is AN-8000MS, and the AN-8500MS itself when it is the AN-8500MS.

**Step 1.** Using the up or down arrow keys or the [1] key on the maintenance screen, move the cursor to "1: Network set."



→ 1: Network set  
2: LineAttribute

**Step 2.** Press the Select key to display the IP address of the exchange to which the station is connected or of the AN-8500MS.



IP Address  
→ 192.168.001.128

**Step 3.** Using the dial keys, enter the desired IP address, then press the Select key. When not changing the IP address, press the Select key only. The subnet mask of the exchange or AN-8500MS is displayed.

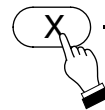

IP Address  
→ 192.168.005.064

- The periods (.) within the IP address need not be entered. Enter numerals consecutively.
- If a number separated by a period is a single or double digit number, add the prefix [0] or [00] to make them 3-digit numbers. For example, enter the IP address "192.168.5.64" as "192168005064."



Subnet mask  
→ 255.255.255.000

**Step 4.** Using the dial keys, enter the desired subnet mask, then press the Select key. When not changing the subnet mask, press the Select key only. The default gateway of the exchange or AN-8500MS is displayed.

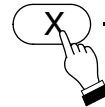

Subnet mask  
→ 255.255.000.000

**Note**

For entering figures, follow the same process as **Step 3**.



Default gateway  
→ 192.168.001.254

**Step 5.** Using the dial keys, enter the desired default gateway, then press the Select key. When not changing the default gateway, press the Select key only.

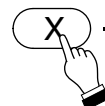

Dafault gateway  
→ 192.168.254.001

The screen reverts to the system setting item selection display, completing the change in network settings.

**Note**

For entering figures, follow the same process as **Step 3**.



→ 1: Network set  
2: LineAttribute

**Step 6.** Press the Menu key to return the display to its normal standby mode.



10:08 AM  
2000

**Note**

Network settings are not immediately updated, but must be made effective by restarting the exchange or AN-8500MS.

To restart the exchange, press the Reset key located on the front panel of the exchange or use the exchange reset screen (refer to [p. 7-8](#)).

To restart the AN-8500MS, use the exchange reset screen (refer to [p. 7-8](#)).

### 6.3. Station Number Settings

It is possible to set the station number for all stations and IP stations.

**Step 1.** Using the up or down arrow keys or the [2] key on the maintenance screen, move the cursor to "2: Line Attribute."



1: Network set  
→ 2: Line Attribute

**Step 2.** Press the Select key to display the line attribute setting screen.

SELECT



Line attribute  
→ Exchange No.:

**Step 3.** Enter the equipment number (01 to 80) of the Exchange or IP station to be set with the dial keys (2-digit number), then press the Select key.

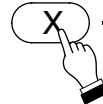

Line attribute  
→ Exchange No.: 24

SELECT



**Step 4.** Enter the line number (01 – 16) of the line to be set with the dial keys (2-digit number), then press the Select key.  
For IP stations, select the line number 01.

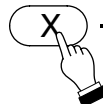

EX 24: → LINE 01  
No programming

SELECT



EX 24: LINE 01  
→ No programming

**Step 5.** Use the arrow keys or dial key to select the type of station connected to the designated line, then press the Select key.  
The types of stations selectable at this point are as follows.



EX 24: LINE 01  
→ Multifunction

SELECT



Dial key	Indication	Type of stations	Corresponding model
0	No programming	—	Non
1	8000MS	Multifunctional master station, IP Multifunctional master station	AN-8000MS/8500MS
2	8010MS	Standard master station	AN-8010MS
3	8011MS	Hands-free master station	AN-8011MS
4	8020MS	Industrial-use master station	AN-8020MS
5	8031MS	Flush-mount master station	AN-8031MS
6	8050DS	Door station, IP door station	AN-8050DS/8540DS

Selecting "No programming" only completes the registration and reverts the screen back to **Step 2**, permitting the next Exchange number to be entered for the line attribute setting.

Line attribute  
→ Exchange No.:

**Step 6.** Enter the station number (00-999999) of the designated line using the dial keys, then press the Select key.  
Only if "8050DS" has been selected, the designated master station number setting screen appears. Proceed to **Step 7**.  
When other items are selected, the registration is completed and the screen reverts to **Step 2**, permitting the next Exchange number to be entered for the line attribute setting.



SELECT



**Step 7.** (Door station and IP door station only)  
Enter the designated master station number (00-999999) using the dial keys, then press the Select key.  
The registration is completed and the screen reverts to **Step 2**, permitting the next Exchange number to be entered for the line attribute setting.

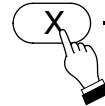

SELECT



**Step 8.** Press the Menu key to return the display to its normal standby mode.

MENU

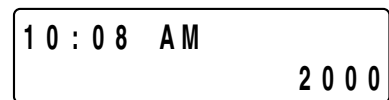

## 6.4. System Clock Settings

The clock of the exchange or AN-8500MS\* can be set as needed. This function is useful if there are time differences among exchanges connected to the system.

\* Exchange when the station performing setting is AN-8000MS, and the AN-8500MS itself when it is the AN-8500MS.

**Step 1.** Using the up or down arrow keys or the [3] key on the maintenance screen, move the cursor to "3: Clock set."



**Step 2.** Press the Select key to display the clock setting screen.

SELECT

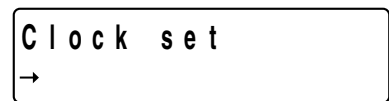

**Step 3.** Use the dial keys to enter the time to be set for the exchange or AN-8500MS in two-digit sets in the order Hours:Minutes:Seconds.  
• Enter the time in 24-hour format.  
• Colons (:) need not be entered.

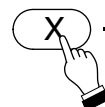

**Step 4.** Press the Select key to revert the screen to **Step 1**.

SELECT



**Step 5.** Press the Menu key to return the screen to ordinary standby mode with the updated time displayed.

MENU

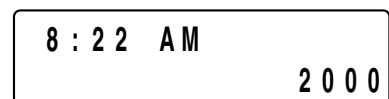

## 6.5. Restarting the Equipment

Restart the exchange or AN-8500MS\* when network settings have been changed. The exchange can be restarted at the Multifunctional Station even without pressing "Reset" key located on the exchange's front panel.

\* Exchange when the station performing restart is AN-8000MS, and the AN-8500MS itself when it is the AN-8500MS.

### Note

Before restarting the exchange, ensure that no paging, conversation, or firmware update is in progress.

**Step 1.** Using the up or down arrow keys or the [4] key on the maintenance screen, move the cursor to "4:Reset EX."



```
3 : C l o c k   s e t t i n g
→ 4 : R e s e t   E X
```

**Step 2.** Press the Select key to display verification screen.



```
R e s e t   E X .   O K ?
Y e s → N o
```

**Step 3.** Pressing the left or right arrow keys, move the cursor to "Yes."



```
R e s e t   E X .   O K ?
→ Y e s   N o
```

**Step 4.** Press the Select key to revert the screen to **Step 1**, then the Exchange or AN-8500MS restarts. Dialing operations are refused during restarting. When restart has been completed, the display returns to its normal standby mode.



```
3 : C l o c k   s e t t i n g
→ 4 : R e s e t   E X
```

```
8 : 2 2   A M
                                     2 0 0 0
```

# ***Chapter 8***

---

## ***APPENDIX***

# 1. BASIC KNOWLEDGE ABOUT NETWORKS

## 1.1. IP Networks and Address

The IP networks that the Exchanges, Multi interface units and IP stations can use include Local Area Networks (LAN) used in small-scale area, such as within or on the premises of a company, and the Internet, which covers a wide area over remote distances.

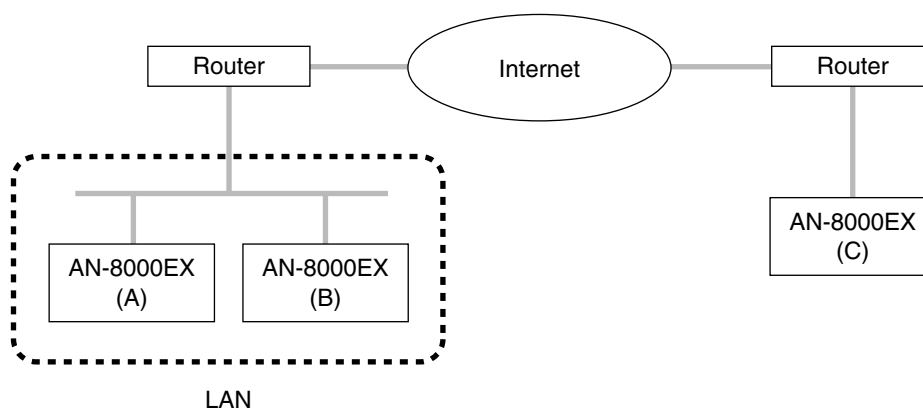

LANs differ from the Internet in the IP address to be used.

Local IP address (private IP address):

This address is used and can be freely set within the LAN.

Global IP address:

This is the only one address that is used to access the Internet.

To use the Exchanges, Multi interface units and IP stations through the Internet, a fixed global IP address must be acquired and assigned to each unit. When using the router, set the global IP address to it.

When a connection is made from Unit B to Unit A in the above figure, the local address can be used. However, when a connection is made from Unit C to Unit A, the global IP address must be used.

The fixed global IP address must be assigned to the units connected via the Internet.

Consult with a network administrator or IPS (Internet service provider) for the acquisition of a fixed global IP address.

### Note

The Internet is not guaranteed quality. Packet loss may result if the network is congested, possibly causing voice communications to be interrupted or noise to be generated.

## 1.2. Network Address Port Translation (NAPT, IP Masquerade) and AN-8000 Software Program

Because the Internet cannot be accessed using the local IP address, the local IP address must be converted into global IP address by means of Network Address Port Translation (NAPT, IP Masquerade).

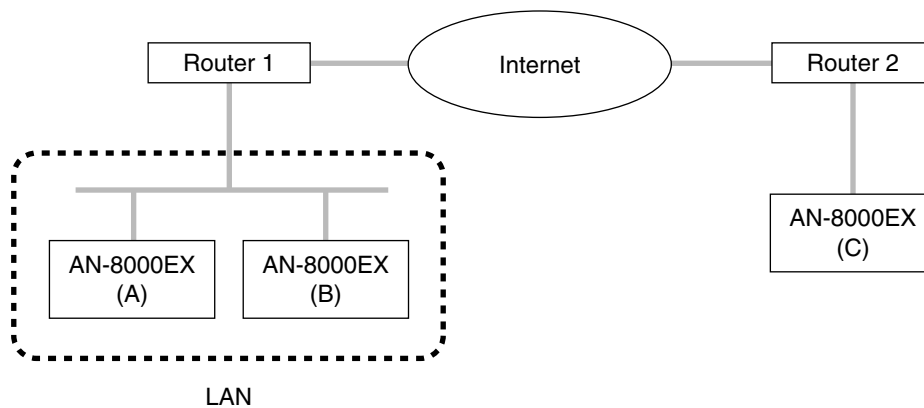

Connection can be made from Unit C to Unit A using the global IP address. The global IP address used for the connection is converted into the local address for Unit A by Router 1.

The AN-8000 Software program is designed for full compatibility with the NAPT (IP Masquerade). When performing settings for the equipment connected by means of NAPT (IP Masquerade), tick the "NAPT compatible" item displayed by pressing on the "Network setting tab" of the Exchange, Multi interface unit, or IP station, and enter the router's IP address and Port No. (Refer to [p.5-24](#), [5-31](#) and [5-42](#).)



### 1.3. Unicast vs. Multicast Communications

When making paging calls via multiple exchanges, multi interface units, or IP stations connected to a network, either "unicast" or "multicast" may be selected as the communication method. For unicast communications, separate data packets are created and sent individually to each destination IP address. For multicast communications, however, a single data packet is transmitted to a special IP address, which offers the advantage of allowing the communication band to be compressed. Note, however, that multicast communications require routers and other networking equipment connected to the network (excluding non-intelligent hubs and switches) that support appropriate protocols like the Internet Group Management Protocol (IGMP) to enable packet transmission to special multicast addresses. The valid multicast address range for the AN-8000 System is from 225.0.0.0 to 238.255.255.255.

- Consult your network administrator regarding the details of setting the multicast address, including confirming whether or not such communications are possible.  
To use the unicast method, the number of transmission source communication bands must equal the number of transmission destination exchanges, multi interface units, or IP stations.

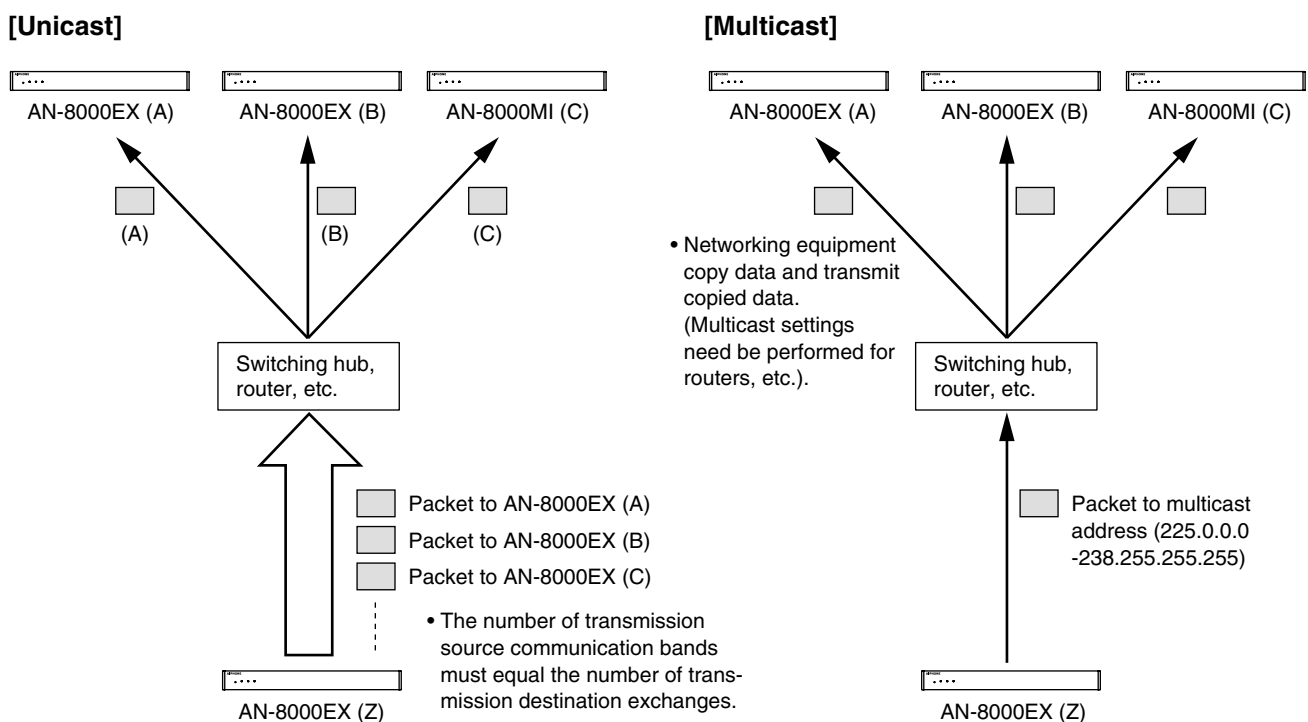

### 1.4. Network Paging Restrictions

When performing unicast or multicast paging via a network, the numbers of paging destinations are restricted as follows.

- Multicast Paging: Up to 79 destinations
- Unicast Paging: Up to 16 destinations
- Multicast/Unicast Combined paging: Up to 79 destinations combined (including up to 15 unicast destinations)

## 1.5. Unit Scan and Broadcast Communications Domains

The broadcast communications method is utilized to detect equipment (exchange, multi interface unit, or IP station) connected to a network. Therefore, only equipment within the network's multicasting range will be detected. This range is called the "broadcast domain." The broadcast address used for detection is 255.255.255.255. Normally, a broadcast packet does not reach beyond a router, even within a local area network.

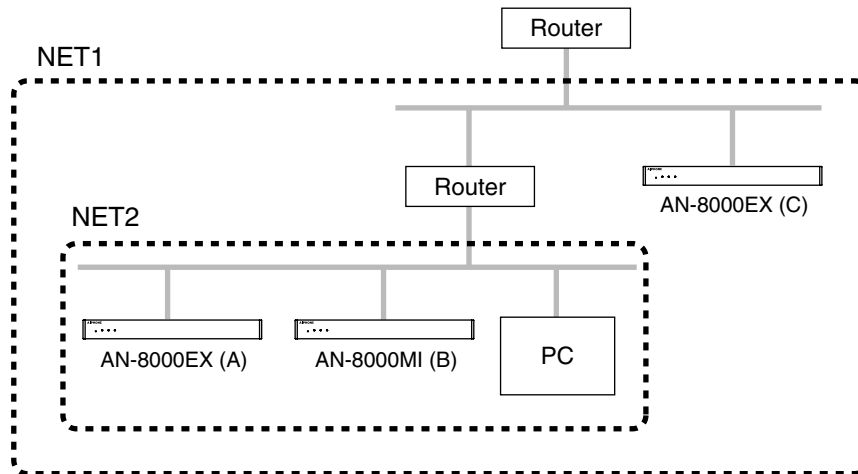

In the above figure, NET 1 represents a network, while NET 2 is the valid broadcasting range. In this example, if the PC performs equipment detection, it will not be able to detect Equipment C despite its location within the same local area network.

Consult your network administrator regarding the valid broadcast range.

## 1.6. Sampling Frequency Correction (AN-8000EX/8000MI only)

This function is used to correct and synchronize the operating clocks for all exchanges and multi interface units on the system to the same value. Failure to synchronize operating clocks in this way may result in word dropout during broadcasts over two minutes.

By default, automatic correction is enabled for equipment within the above broadcast domain. To correct sampling frequencies between equipment connected to different networks divided by a router or other equipment (for example "Network A" and "Network B"), first correct the sampling frequency setting for one of the exchanges or multi interface units connected to Network A, and designate the IP address of one of the exchanges or multi interface units connected to Network B as a corrected data transmission destination, then perform the correction data receiving setting for that Network B exchange.

The number of destinations to which correction data can be transferred to is limited to 16 total for unicast and multicast combined.

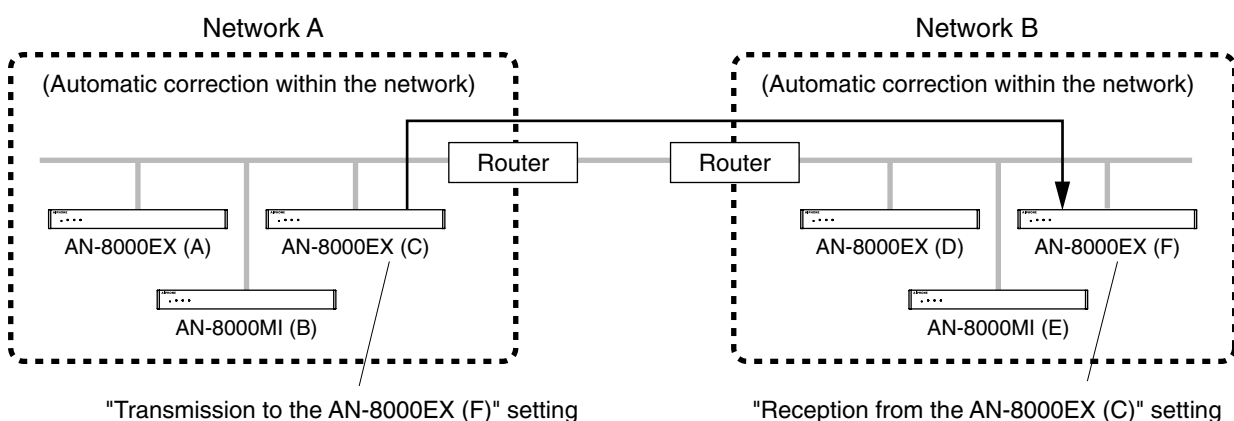

## 2. IF TROUBLE OCCURS:

Symptom	Potential Cause/Place to Inspect	Remedy
The exchange or multi interface unit does not operate.	Power and cables may not be connected correctly.	Connect the power source and cables properly.
	All indicators located on the equipment's front panel may be out.	Make sure the power is turned on.
	Check to see if the equipment's front panel Status indicator remains lit or if flashes repeatedly three times at one-second intervals.	Refer to "Indicator Status & Troubleshooting" on <a href="#">p. 8-8</a> .
The IP station does not operate.	Power and cables may not be connected correctly.	Connect the power source and cables properly.
	Check to see if the Status indicator remains lit or if flashes repeatedly three times at one-second intervals.	Refer to "Indicator Status & Troubleshooting" on <a href="#">p. 8-8</a> .
The AN-8000 Software fails to recognize the exchange, multi interface unit, or IP station. (Includes the case when network setting is available)	The PC on which the AN-8000 Software is installed may not be connected or set correctly.	Set and connect the PC's IP address, subnet mask, and default gateway correctly.
	The equipment's IP address, subnet mask, default gateway, or port number may not be set correctly.	Set the equipment's IP address, subnet mask, default gateway, and port number correctly. (See <a href="#">p. 5-9</a> , <a href="#">6-5</a> .)
	If connected to another network via a router, the router may not be connected correctly.	Confirm with your network administrator that the router is connected correctly.
The browser setting screen fails to display correctly. (Includes the case when network setting is available)	The PC used for exchange data settings via browser may not be connected correctly to the network, or the browser may not be set correctly.	Perform settings or connections correctly. (See <a href="#">p. 6-2</a> .)
	The setting screen uses Java Script. The browser used may not support Java Script, or the Java Script function may be disabled.	When using Internet Explorer, select [Tool] → [Internet option] → [Security] → [Customize level] on the menu, then set [Script] → [Active script] → [Validate] or → [Display dialog].
	The browser is set to the option "Via a proxy."	The screen may not be correctly displayed if "Via a proxy" is selected for the browser. Consult your network administrator to find work-around measures.

Symptom	Potential Cause/Place to Inspect	Remedy
No voice is output or the sound is distorted.	The exchange or multi interface unit may not be connected correctly to the amplifiers and/or speakers.	Connect the amplifiers and/or speakers correctly.
	The amplifier's audio input volume control may not be adjusted correctly.	Adjust the audio input volume control correctly.
	The amplifier's audio input level selector switch may not be set correctly.	Set the audio input level selector switch correctly.
	Voice and sound settings may not be performed correctly.	Perform the "Broadcast Specification" setting correctly. (See p. 5-24, 5-31, 5-42.)
Voice signals include intermittent noise or break up.	The network may be congested. Check the contents of log.	When the network is congested, consult with the network administrator.
No sound is output from the station's internal or external speaker. (AN-8000MS/8020MS/8500MS only).	The speaker selector switch may not be set correctly.	Set the speaker selector switch located on the station's bottom surface to the speaker type you want to use.
The exchange generates excessive heat.	Check to see if the exchange's front panel-mounted Status indicator flashes continuously.	The exchange may be malfunctioning. Contact your nearest AIPHONE sales office immediately.
The system temporarily stops operating but is restored after a few seconds.	Check to see if the indication "Firmware failed. Please contact our sales office." is displayed in the operation log.	A problem has occurred and the system has been reset. Nonetheless, since there is a chance that the system may fail again, please contact your nearest AIPHONE sales office immediately.
The LNK/ACT indicator does not illuminate for exchange or multi interface unit. The FD indicator does not illuminate for IP station.	The LAN cable may not be connected correctly. Check to see if the switching hub is connected to an appropriate port with the correct type of cable.	Connect the LAN cable correctly.
	The switching hub may not be turned on.	Turn on the switching hub.
Station does not operate.	The cable may not be connected correctly.	Connect the cable correctly.
A password has been forgotten.	—	Contact your nearest AIPHONE sales office .

### 3. INDICATOR STATUS & TROUBLESHOOTING

#### [Exchange and multi interface unit]

The following table shows the Status indicator mode, its corresponding equipment condition or symptom, and any measures to be taken in the event of system failure.

AN-8000EX/8000MI front panel

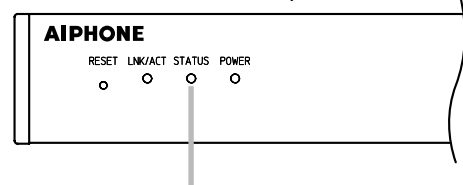

Status indicator

Status Indicator	Equipment Condition	Action to Take
OFF	Normal operation or power OFF	—
Rapid flashing* (in a cycle of 200 ms)	Failure of fan (exchange is operating normally)	Contact your nearest AIPHONE sales office.
Flashes three times in a row (in a cycle of 200 ms) at one-second intervals.	Failure	Contact your nearest AIPHONE sales office.
Lights for a few seconds repeatedly at certain intervals.	Accessing flash memory (normal operation).	Never turn off the power or press the Reset key until the indicator extinguishes completely.
Remains lit (for long hours).	Failure	Contact your nearest AIPHONE sales office.
Flashes slowly (in a cycle of 4 s)	Operation in progress in a mode not usually used.	Press the Reset key to return to normal operation mode.

\* Applicable to the exchange only

#### [IP station]

Station status can be confirmed by checking the status indicator while the station is in normal standby mode.

Take appropriate measures according to the equipment condition referring to the table below.

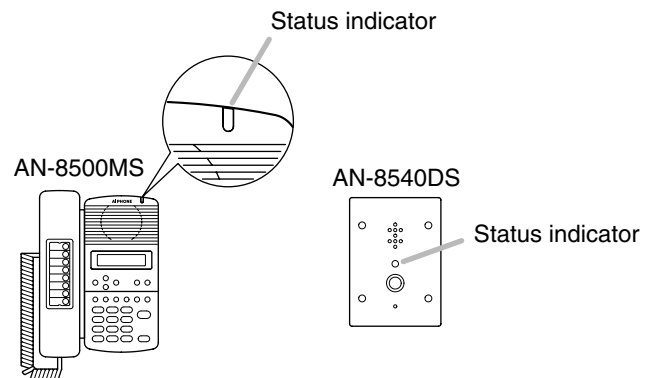

Status Indicator	Equipment Condition	Action to Take
OFF	Normal operation or power OFF	—
Flashes three times in a row (in a cycle of 200 ms) at one-second intervals.	Failure	Contact your nearest AIPHONE sales office.
Lights for a few seconds repeatedly at certain intervals.	Accessing flash memory (normal operation).	Never turn off the power nor restart the station until the indicator extinguishes completely.
Flashes slowly (in a cycle of 4 s)	Operation in progress in a mode not usually used.	Restart the station to return to normal operation mode.

## 4. SPECIFICATIONS

### 4.1. AN-8000EX IP Intercom Exchange

Power Source	AC Mains, 50/60 Hz
Power Consumption	50 W (rated), 75 W (max.)
Type of Speech Path	Space sharing/Time sharing
Speech Link	Internal: 4, External: 8 (both Half duplex/Full duplex use)
Hands-free Speech Method	Simultaneous conversation by way of echo canceller or Half duplex conversation by way of voice switch
Line Capacity	Up to 16 stations
Wiring Method	Non-polar one pair stranded wire system
Transmission System	2-wire 160 kbps echo canceller transmission system
Signal Level	Under 0 dB*
Transmission Range	Max. 1,500 m (ø 0.65 mm, Loop resistance: 170 Ω or less)
Power Supply to Station	48 V DC, Max. 70 mA
Paging Output	Audio : 2 lines, Max. 0 dB*, 600 Ω, balanced, removable terminal block Control: 2 channels, no-voltage make contact output (24 V DC/0.5 A), removable terminal block
Connecting Terminal	Dedicated connectors
Others	Firmware update function, System registration data entry hold facility, Time of day hold facility, Forced air-cooling, Reset switch (front panel)
Network Section	
Network I/F	10BASE-T/100BASE-TX (Automatic switching)
Network Protocol	TCP/IP, UDP, ARP, ICMP, HTTP, RTP, IGMP
Audio Packet Transmission System	Unicast (simultaneous paging to up to 16 zones) Multicast (simultaneous paging to up to 79 zones)
Connector	RJ-45 connector
Voice Sampling Frequency	16 kHz, 8 kHz (switchable on the software)
Quantifying Bit Number	16 bits
Voice Encoding Method	Sub-band ADPCM, Cryptosystem
Audio Packet Loss Compensation System	Silence insertion
Audio Delay Time	80 ms, 320 ms (switchable on the software)
Indication	Network LNK/ACT indication, Status Lamp, Power-on indication lamp
Installation Method	Rack, Desk-top, Surface mounting
Operating Temperature	0°C to +40°C
Operating Humidity	Under 90% RH (no condensation)
Finish	Pre-coated steel plate, black, 30% gloss
Dimensions	420 (w) x 44.3 (h) x 356 (d) mm
Weight	4.1 kg

\* 0 dB = 1 V

**Note:** The design and specifications are subject to change without notice for improvement.

#### • Accessories

AC power cord (2 m) .....	1	Rack mounting bracket .....	2
CD (for PC setting, maintenance use) .....	1	Tapping screw 3 x 8 .....	8
Removable terminal plug (4 pins) .....	2	Rack mounting screw with plain washer .....	4
Mini-clamp connector (2 pins) .....	20	Wall mounting bracket .....	2
Plastic foot .....	4	Wood screw 3.5 x 20 .....	4
Machine screw M4 x 20 .....	4		

## 4.2. AN-8000MI Multi Interface Unit

Power Source	CE version: 230 V AC, 50/60 Hz, CU version: 120 V AC, 50/60 Hz
Power Consumption	CE version: 19 W (180 mA) (at rated), 24 W (230 mA) (max.) CU version: 16 W (250 mA) (at rated), 21 W (330 mA) (max.)
Audio Input	Input : 2 inputs (2 P/input), Max. 0 dB* <sup>1</sup> , under 600 Ω, balanced, with a semi-fixed volume for adjustment (0 to -25 dB) Control: 2 inputs (2 P/input), no-voltage make contact input, open voltage: 12 V DC, short-circuit current: 10 mA Removable terminal block (8 pins)
Audio Output	Output : 2 outputs (2 P/output), Max. 0 dB* <sup>1</sup> , under 600 Ω, balanced Control: 2 outputs (2 P/output), relay contact output, contact capacity: 24 V DC/0.5 A Removable terminal block (8 pins)
Contact Input	16 inputs, no-voltage make contact input, open voltage: 12 V DC, short-circuit current: under 10 mA, removable terminal block (9 pins)
Contact Output	16 outputs, relay contact output, contact capacity: 24 V DC/0.5 A, removable terminal block (9 pins)
PBX I/F	PBX input and output: 2 channels, Max., under 0 dB* <sup>2</sup> , average: under -15 dB* <sup>2</sup> , 600 Ω, balanced, mini-clamp connector (2 pins), with adjustment functions for both input and output (input: 0 to +15 dB, Output: -15 to 0 dB), Analog E & M interface
Others	Firmware update function, System registration data entry hold facility, Time of day hold facility, Reset switch (front panel)
Network Section	
Network I/F	10BASE-T/100BASE-TX (auto sensing)
Network Protocol	TCP/IP, UDP, ARP, ICMP, HTTP, RTP, IGMP
Audio Packet Transmission System	Unicast (simultaneous paging to up to 16 zones) Multicast (simultaneous paging to up to 79 zones)
Connector	RJ-45 connector
Voice Sampling Frequency	16 kHz, 8 kHz (switchable on the software)
Quantifying Bit Number	16 bits
Voice Encoding Method	Sub-band ADPCM, Cryptosystem
Audio Packet Loss Compensation System	Silence insertion
Audio Delay Time	80 ms, 320 ms (switchable on the software)
Indication	Network LNK/ACT indication, Status Lamp, Power-on indication lamp
Installation Method	Rack, Desk-top, Surface mounting
Operating Temperature	0°C to +40°C
Operating Humidity	Under 90% RH (no condensation)
Finish	Pre-coated steel plate, black, 30% gloss
Dimensions	420 (w) x 44.3 (h) x 239.5 (d) mm
Weight	2.8 kg

\*<sup>1</sup> 0 dB = 1 V      \*<sup>2</sup> 0 dB = 0.775 V

**Note:** The design and specifications are subject to change without notice for improvement.

### • Accessories

AC power cord (2 m) .....	1	Machine screw M4 x 20 .....	4
CD (for PC setting, maintenance use) .....	1	Rack mounting bracket .....	2
Removable terminal plug (9 pins) .....	4	Tapping screw 3 x 8 .....	8
Removable terminal plug (8 pins) .....	2	Rack mounting screw with plain washer .....	4
Mini-clamp connector (2 pins) .....	10	Wall mounting bracket .....	2
Plastic foot .....	4	Wood screw 3.5 x 20 .....	4

### 4.3. AN-8500MS IP Multifunctional Master Station

Power Source	Power supply device that complies with IEEE802.3af standard or 12 V DC (supplied from the AC adapter AD-1210P)
Power Consumption	4.2 W (rated), 6 W (max.)
Speech Method	Hands-free or handset conversation
Audio Frequency Range	300 – 7,000 Hz
Hands-Free	Speaker: 5.7 cm cone-type, 0.6 W, 8 Ω Microphone: Omni-directional electret condenser microphone
Handset	Receive path: Cone-type, Send path: Electret condenser microphone
Headset Terminal	Speaker: 3 mW, 32 Ω, Microphone: –49 dB*, ø 3.5 mm mini jack
External Speaker Terminal	0.6 W, 8 Ω, screwless connector (2pins)
Network Section	
Network I/F	10BASE-T/100BASE-TX (Automatic switching)
Network Protocol	TCP/IP, UDP, ARP, ICMP, HTTP, RTP, IGMP
Audio Packet Transmission System	Unicast (1 speech link, simultaneous paging to up to 16 zones) Multicast (simultaneous paging to up to 79 zones)
Connector	LAN: RJ-45 connector (PoE compatible) PC: RJ-45 connector (not-compatible with PoE)
Voice Sampling Frequency	16 kHz, 8 kHz (switchable on the software)
Quantifying Bit Number	16 bits
Voice Encoding Method	Sub-band ADPCM, Cryptosystem
Audio Packet Loss Compensation System	Silence insertion
Audio Delay Time	80 ms, 320 ms (switchable on the software)
Display	LCD: Alphanumeric characters (16 characters x 2 lines)
Installation Method	Desk-top/Surface mounting (When mounting on the wall, use the optional YC-280.)
Operating Temperature	0°C to +40°C
Operating Humidity	Under 90% RH (no condensation)
Finish	Body, Handset: ABS resin, black
Dimensions	148 (w) x 208 (h) x 70.5 (d) mm
Weight	810 g

\* 0 dB = 1 V

**Note:** The design and specifications are subject to change without notice for improvement.

#### • Accessories

CD (for PC setting, maintenance use) ..... 1  
Ferrite clamp ..... 1

#### • Optional products

Wall mounting bracket: YC-280  
AC adapter: AD-1210P



#### 4.4. AN-8540DS IP Door Station

Power Source	Power supply device that complies with IEEE802.3af standard or 12 V DC (supplied from the AC adapter AD-1210P)
Power Consumption	4.2 W (rated), 6 W (max.)
Speech Method	Hands-free or handset conversation
Audio Frequency Range	300 – 7,000 Hz
Hands-Free	Speaker: 3.5 cm cone-type, 1 W, 8 Ω Microphone: Omni-directional electret condenser microphone
Contact Output	Open collector output, withstand voltage: 30 V DC, control current: 50 mA, one shot: can be set from 1 to 9 sec, screw terminal (polarized)
Network Section	
Network I/F	10BASE-T/100BASE-TX (Automatic switching)
Network Protocol	TCP/IP, UDP, ARP, ICMP, HTTP, RTP, IGMP
Audio Packet Transmission System	Unicast (1 speech link, simultaneous paging to up to 16 zones) Multicast (simultaneous paging to up to 79 zones)
Connector	RJ-45 connector (PoE compatible)
Voice Sampling Frequency	16 kHz, 8 kHz (switchable on the software)
Quantifying Bit Number	16 bits
Voice Encoding Method	Sub-band ADPCM, Cryptosystem
Audio Packet Loss Compensation System	Silence insertion
Audio Delay Time	80 ms, 320 ms (switchable on the software)
Installation Method	Flush/Surface mounting
Operating Temperature	-10°C to +50°C
Operating Humidity	Under 90% RH (no condensation)
Finish	Plate: Stainless steel (SUS304), hairline
Dimensions	115 (w) x 162 (h) x 53.5 (d) mm
Weight	700 g

\* 0 dB = 1 V

**Note:** The design and specifications are subject to change without notice for improvement.

##### • Accessories

Oval head slotted screw UNC No.6 x 18 .....	4
Oval head combination screw M4 x 25 .....	4
Ferrite clamp .....	1

##### • Optional products

Back box:	YC-150 (For flush mounting)
Wall-mount Box:	YS-13A (For surface mounting)
AC adapter:	AD-1210P

#### 4.5. AN-8000MS Multifunctional Master Station

Power Source	48 V DC (supplied from the AN-8000EX IP Intercom Exchange)
Power Consumption	1.8 W (rated), 2.4 W (max.)
Wiring Method	Non-polar one pair stranded wire system
Transmission System	2-wire 160 kbps echo canceller transmission system
Signal Level	Under 0 dB*
Speech Method	Hands-free or handset conversation
Audio Frequency Range	300 – 7,000 Hz
Transmission Range	Max. 1,500 m ( $\varnothing$ 0.65 mm, Loop resistance 170 $\Omega$ or less)
Hands-Free	Speaker: 5.7 cm cone-type, 0.6 W, 8 $\Omega$ Microphone: Omni-directional electret condenser microphone
Handset	Receiver: Cone-type Microphone: Electret condenser microphone
Display	Alphanumeric characters (16 characters x 2 lines LCD)
Line Connecting Terminal	RJ-11 modular jack
Headset Terminal	Speaker: 3 mW, 32 $\Omega$ , Microphone: -49 dB*, $\varnothing$ 3.5 mm mini jack
External Speaker Terminal	0.6 W, 8 $\Omega$ , screwless connector (2pins)
Installation Method	Desk-top/Surface mounting (When mounting on the wall, use the optional YC-280.)
Operating Temperature	0°C to +40°C
Operating Humidity	Under 90% RH (no condensation)
Finish	Body, Handset: ABS resin, black
Dimensions	148 (w) x 208 (h) x 70.5 (d) mm (excluding the handset cord)
Weight	800 g

\* 0 dB = 1 V

**Note:** The design and specifications are subject to change without notice for improvement.

##### • Accessories

Connection cord (3 m) ..... 1

##### • Optional product

Wall mounting bracket: YC-280

## 4.6. AN-8010MS Standard Master Station

Power Source	48 V DC (supplied from the AN-8000EX IP Intercom Exchange)
Power Consumption	1.8 W (rated), 2.4 W (max.)
Wiring Method	Non-polar one pair stranded wire system
Transmission System	2-wire 160 kbps echo canceller transmission system
Signal Level	Under 0 dB*
Speech Method	Hands-free or handset conversation
Audio Frequency Range	300 – 7,000 Hz
Transmission Range	Max. 1,500 m ( $\varnothing$ 0.65 mm, Loop resistance 170 $\Omega$ or less)
Hands-Free	Speaker: 5.7 cm cone-type, 0.6 W, 8 $\Omega$ Microphone: Omni-directional electret condenser microphone
Handset	Receiver: Cone-type Microphone: Electret condenser microphone
Line Connecting Terminal	RJ-11 modular jack
Installation Method	Desk-top/Surface mounting (When mounting on the wall, use the optional YC-280.)
Operating Temperature	0°C to +40°C
Operating Humidity	Under 90% RH (no condensation)
Finish	Body, Handset: ABS resin, black
Dimensions	148 (w) x 208 (h) x 70.5 (d) mm (excluding the handset cord)
Weight	700 g

\* 0 dB = 1 V

**Note:** The design and specifications are subject to change without notice for improvement.

### • Accessories

Connection cord (3 m) ..... 1

### • Optional product

Wall mounting bracket: YC-280

#### 4.7. AN-8011MS Standard Hands-Free Master Station

Power Source	48 V DC (supplied from the AN-8000EX IP Intercom Exchange)
Power Consumption	1.8 W (rated), 2.4 W (max.)
Wiring Method	Non-polar one pair stranded wire system
Transmission System	2-wire 160 kbps echo canceller transmission system
Signal Level	Under 0 dB*
Speech Method	Hands-free conversation
Audio Frequency Range	300 – 7,000 Hz
Transmission Range	Max. 1,500 m ( $\phi$ 0.65 mm, Loop resistance 170 $\Omega$ or less)
Hands-Free	Speaker: 5.7 cm cone-type, 0.6 W, 8 $\Omega$ Microphone: Omni-directional electret condenser microphone
Line Connecting Terminal	RJ-11 modular jack
Installation Method	Desk-top/Surface mounting (When mounting on the wall, use the optional YC-290.)
Operating Temperature	0°C to +40°C
Operating Humidity	Under 90% RH (no condensation)
Finish	Body: ABS resin, black
Dimensions	92 (w) x 195 (h) x 56.1 (d) mm
Weight	400 g

\* 0 dB = 1 V

**Note:** The design and specifications are subject to change without notice for improvement.

##### • Accessories

Connection cord (3 m) ..... 1

##### • Optional product

Wall mounting bracket: YC-290

#### 4.8. AN-8020MS Industrial-Use Master Station

Power Source	48 V DC (supplied from the AN-8000EX IP Intercom Exchange)
Power Consumption	1.8 W (rated), 2.4 W (max.)
Wiring Method	Non-polar one pair stranded wire system
Transmission System	2-wire 160 kbps echo canceller transmission system
Signal Level	Under 0 dB*
Speech Method	Hands-free or handset conversation
Audio Frequency Range	300 – 7,000 Hz
Transmission Range	Max. 1,500 m ( $\varnothing$ 0.65 mm, Loop resistance 170 $\Omega$ or less)
Hands-Free	Speaker: 5.7 cm cone-type, 0.6 W, 8 $\Omega$ Microphone: Omni-directional electret condenser microphone
Handset	Receiver: Cone-type Microphone: Electret condenser microphone
Dial-in Contact Output	Open collector output (polarized), withstand voltage: Max. 30 V DC, control current: Max. 50 mA, screwless connector (2 pins)
Line Connecting Terminal	RJ-11 modular jack
External Speaker Terminal	0.6 W, 8 $\Omega$ , screwless connector (2 pins)
Installation Method	Desk-top/Surface mounting (When mounting on the wall, use the optional YC-280.)
Operating Temperature	-10°C to +50°C
Operating Humidity	Under 90% RH (no condensation)
Dust/Water Protection	IP54
Finish	Body, Handset: ABS resin, gray
Dimensions	170 (w) x 220 (h) x 97.8 (d) mm (excluding the handset cord and projection sections)
Weight	1 kg

\* 0 dB = 1 V

**Note:** The design and specifications are subject to change without notice for improvement.

##### • Accessories

Rubber cap ..... 2

##### • Optional product

Wall mounting bracket: YC-280

## 4.9. AN-8031MS Flush-Mount Master Station

Power Source	48 V DC (supplied from the AN-8000EX IP Intercom Exchange)
Power Consumption	1.8 W (rated), 2.4 W (max.)
Wiring Method	Non-polar one pair stranded wire system
Transmission System	2-wire 160 kbps echo canceller transmission system
Signal Level	Under 0 dB*
Speech Method	Hands-free conversation (Handset conversation can be established in conjunction with the RS-191.)
Audio Frequency Range	300 – 7,000 Hz
Transmission Range	Max. 1,500 m ( $\phi$ 0.65 mm, Loop resistance 170 $\Omega$ or less)
Hands-Free	Speaker: 5.7 cm cone-type, 0.6 W, 8 $\Omega$ Microphone: Omni-directional electret condenser microphone
Line Connecting Terminal	Pin header (2 pins)
External Dial Input	No-voltage make contact input, screwless connector (5 pins)
Installation Method	Flush/Surface mounting
Operating Temperature	0°C to +40°C
Operating Humidity	Under 90% RH (no condensation)
Finish	Panel: Stainless steel (SUS304), hairline
Dimensions	115 (w) x 254 (h) x 54.6 (d) mm
Weight	850 g

\* 0 dB = 1 V

**Note:** The design and specifications are subject to change without notice for improvement.

### • Accessories

Oval head slotted screw UNC No.6 x 18 .....	4
Oval head combination screw M4 x 25 .....	4
Removable terminal plug (2 pins, preinstalled on the unit) .....	1
Headset jumper (8 pins, preinstalled on the unit) .....	1

### • Optional products

Back Box:	YC-241 (For flush mounting)
Wall-mount Box:	YC-251 (For surface mounting)
Option Handset:	RS-191

#### 4.10. AN-8050DS Door Station

Power Source	48 V DC (supplied from the AN-8000EX IP Intercom Exchange)
Power Consumption	1.8 W (rated), 2.4 W (max.)
Wiring Method	Non-polar one pair stranded wire system
Transmission System	2-wire 160 kbps echo canceller transmission system
Signal Level	Under 0 dB*
Speech Method	Hands-free conversation
Audio Frequency Range	300 – 7,000 Hz
Transmission Range	Max. 1,500 m (ø 0.65 mm, Loop resistance 170 Ω or less)
Hands-Free	Speaker: 3.5 cm cone-type, 1 W, 8 Ω Microphone: Omni-directional electret condenser microphone
Contact Output	Open collector output, withstand voltage: Max. 30 V DC, control current: Max. 50 mA, one-shot make duration: 1 to 9 s (adjustable), screw terminal (polarized)
Line Connecting Terminal	2-wire screw terminal (non-polar)
Installation Method	Flush/Surface mounting
Operating Temperature	-10°C to +50°C
Operating Humidity	Under 90% RH (no condensation)
Housing Protection	(EN50102): IK02 equivalent
Dust/Water Protection	IP44 (note that panel edges must be sealed at installation.)
Finish	Plate: Stainless steel (SUS304), hairline Call button: Metal
Dimensions	115 (w) x 162 (h) x 52 (d) mm
Weight	680 g

\* 0 dB = 1 V

**Note:** The design and specifications are subject to change without notice for improvement.

##### • Accessories

Oval head slotted screw UNC No.6 x 18 ..... 4  
Oval head combination screw M4 x 25 ..... 4

##### • Optional products

Back box: YC-150 (For flush mounting)  
Wall-mount Box: YS-13A (For surface mounting)

#### 4.11. YC-280 Wall Mounting Bracket

Finish	Surface-treated steel plate, gray, paint
Dimensions	100 (w) x 140 (h) x 31.8 (d) mm
Weight	120 g

**Note:** The design and specifications are subject to change without notice for improvement.

##### • Accessories

Wood screw 3.5 x 20 ..... 2  
Rubber foot ..... 4

##### • Applicable models

AN-8000MS/8010MS/8020MS

#### 4.12. YC-290 Wall Mounting Bracket

Finish	Surface treated steel sheet, gray, paint
Dimensions	64 (w) x 131.5 (h) x 31.8 (d) mm
Weight	100 g

**Note:** The design and specifications are subject to change without notice for improvement.

- **Accessories**

Wood screw 3.5 x 20 ..... 2  
 Rubber foot ..... 4

- **Applicable model**

AN-8011MS

#### 4.13. YC-241 Back Box

Finish	Colored chrome plating
Dimensions	119 (w) x 276 (h) x 67 (d) mm
Weight	100 g

**Note:** The design and specifications are subject to change without notice for improvement.

- **Applicable model**

AN-8031MS

#### 4.14. YC-251 Wall-Mount Box

Finish	Surface-treated steel plate, white
Dimensions	124 (w) x 258.5 (h) x 50.5 (d) mm
Weight	1,060 g

**Note:** The design and specifications are subject to change without notice for improvement.

- **Applicable model**

AN-8031MS

#### 4.15. YC-150 Back Box

Finish	Zinc-plating, t1.6
Dimensions	184 (w) x 119 (h) x 57 (d) mm
Weight	700 g

**Note:** The design and specifications are subject to change without notice for improvement.

- **Applicable model**

AN-8050DS



#### 4.16. YS-13A Wall-Mount Box

Finish	Surface treated steel sheet, ivory, paint
Dimensions	116.5 (w) x 163.5 (h) x 55 (d) mm
Weight	550 g

**Note:** The design and specifications are subject to change without notice for improvement.

##### • Accessories

Machine screw M3 x 12 .....	4	Rubber foot .....	4
Wood screw 3.8 x 16 .....	4	Bushing .....	1

##### • Applicable model

AN-8050DS

#### 4.17. E-7000TB Terminal Board

Line Capacity	80 (40 lines)
Line Connection Terminal	Clip terminal
Finish	Panel: Surface treated steel plate, black, 30% gloss
Dimensions	482 (w) x 132.6 (h) x 108.8 (d) mm
Weight	2.5 kg

**Note:** The design and specifications are subject to change without notice for improvement.

##### • Accessories

Rack mounting screw 5 x 12 .....	4	Name plate .....	4
Fiber washer M5 .....	4	Cord clamp .....	6

#### 4.18. RS-191 Option Handset

Handset Receiver	Dynamic type
Handset Microphone	Electret condenser type
Operating Temperature	0°C to +40°C (Temperature range not to freeze the speaker and switch)
Finish	Surface treated steel sheet, ivory, paint
Dimensions	116 (w) x 220 (h) x 70 (d) mm
Weight	330 g

**Note:** The design and specifications are subject to change without notice for improvement.

##### • Accessories

Oval head slotted screw UNC No.6 x 18 .....	4
Oval head combination screw M4 x 25 .....	4

##### • Applicable model

AN-8031MS

#### 4.19. AD-1210P AC Adapter

Power Source	AC Mains, 50/60 Hz
Output	12 V DC, 1 A
Current Consumption	200 mA (rated output)
Cord Length	1.8 m
Plug	RC6705, center "+"
Operating Temperature	0°C to +40°C
Finish	Case: Noryl resin, black
Weight	470 g

**Note:** The design and specifications are subject to change without notice for improvement.

- **Applicable model**

AN-8500MS/8540DS

## WARRANTY

Aiphone warrants its products to be free from defects of material and workmanship under normal use and service for a period of two years after delivery to the ultimate user and will repair free of charge or replace at no charge, should it become defective upon which examination shall disclose to be defective and under warranty.

Aiphone reserves unto itself the sole right to make the final decision whether there is a defect in materials and/or workmanship; and whether or not the product is within the warranty.

This warranty shall not apply to any Aiphone product which has been subject to misuse, neglect, accident, or to use in violation of instructions furnished, nor extended to units which have been repaired or altered outside of the factory.

This warranty does not cover batteries or damage caused by batteries used in connection with the unit.

This warranty covers bench repairs only, and any repairs must be made at the shop or place designated in writing by Aiphone.

Aiphone will not be responsible for any costs incurred involving on site service calls.