

Configuring an IX-RS Sub Station as a Master Station

Introduction

Most IX Series installations use IX-MV7 master stations or IX-SOFT PC master station software to answer calls from door stations. For smaller sites that will not use video features, it is possible to use an IX-RS sub station in place of a master station.

Limitations

This solution works best for sites where a single door station calls an IX-RS substation(s). This is because the IX-RS can only have a single call destination, so it can struggle to manage multiple door stations. It will not be clear which door is calling the IX-RS, and it will only be able to initiate a call to a single door. A full master station is recommended for these sites.

This document shows the IX-RS working with an IX-SSA door station. This is because the IX-SSA has multiple contact inputs and outputs, allowing the IX-RS to call it and be automatically answered without losing door release. This is useful in situations where the sub station needs to resume communication with the visitor at the door if the call times out, or monitor what is happening outside. The IX-DV and IX-DVF video door stations have the same features available.

IX-SS-2G, IX-EA, IX-DVM, and IX-NVP door stations can also be used with the IX-RS. However, since they only have a single contact input and output, they cannot automatically answer calls from the IX-RS and unlock the door on the same station. Either auto answering or door release will need to be chosen.

On legacy IX-BA and IX-DA door stations, there is not a way to have the IX-RS initiate a call to the door station. The IX-RS can still receive calls from these door stations and unlock them.

Sites that require paging features will need to use a full master station, since the IX-RS cannot initiate a page.

IX Support Tool Settings

Program the system using the IX Support Tool and following the IX Series Quick Start Programming Guide. Once the stations are configured, these steps will allow the door station to call the sub station, and allow the sub station to unlock the door station.

Call Settings

Navigate to **Call Settings**, Called Stations (Door/Sub Stations). The Called Stations will be empty, since door and sub stations are not set to call each other by default. Use the drop-down menus to change the blank to **U**. Click **Update**.

- Call Settings
- Station Information
- Called Stations (Master Station)
- Called Stations (Door/Sub Stations)
- Call Origination
- Incoming Call
- Contactless Call

Station Information					Call Settings		
#	Identification				Total	Called Stations (Door/Sub Stations)	
	Number	Name	Location	Station Type		Group 01	Number / Name / Station Type
0001	0001	IX-SSA		IX-SSA(-*)	1	0001 / IX-SSA / IX-SSA(-*)	0002 / IX-RS / IX-RS-*
0002	0002	IX-RS		IX-RS-*	1	U	

Navigate to **Call Settings**, Station Information. Set the door station's Call Button Function to **Call, Answer Call, End Communication**. Click **Update**.

- Call Settings
- Station Information
- Called Stations (Master Station)
- Called Stations (Door/Sub Stations)
- Call Origination
- Incoming Call
- Contactless Call

Station Information					Call Settings	
#	Identification				Station Information	
	Number	Name	Location	Station Type	Call Button Function	
0001	0001	IX-SSA		IX-SSA(-*)	Call, Answer Call, End Communication	
0002	0002	IX-RS		IX-RS-*	Call	

Configuring the Door Station Relays for Auto Answer

IX door stations do not automatically answer calls from sub stations. This can be resolved by using connecting one of the relay outputs on the door station to one of the option inputs. The wiring will be covered on the next page.

Navigate to **Option Input/Relay Output Settings**, Option Input. This will display Option Input 1, which is what this guide will show. Use the drop-down to set the door station's Function to **Answer Call/Page**, and set the Type to **Break**. Click **Update**.

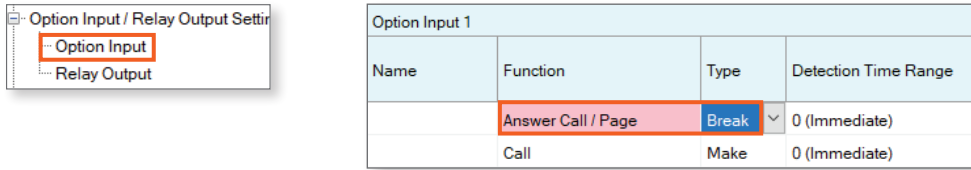

The screenshot shows the 'Option Input / Relay Output Settings' window with 'Option Input' selected. The main table displays the configuration for 'Option Input 1':

Name	Function	Type	Detection Time Range
	Answer Call / Page	Break	0 (Immediate)
Call		Make	0 (Immediate)

Navigate to **Option Input/Relay Output Settings**, Relay Output. This will display Relay Output 1, but the first relay output will be used for door release. Instead, use the drop-down under [Display Settings] to select Relay Output 2.

Under Relay Output 2, make sure that the Function is set for **Status Output**. Under Status Output 2, remove the check boxes under Status Output 2, and check off all three call priority levels under Incoming Call. Click **Update**.

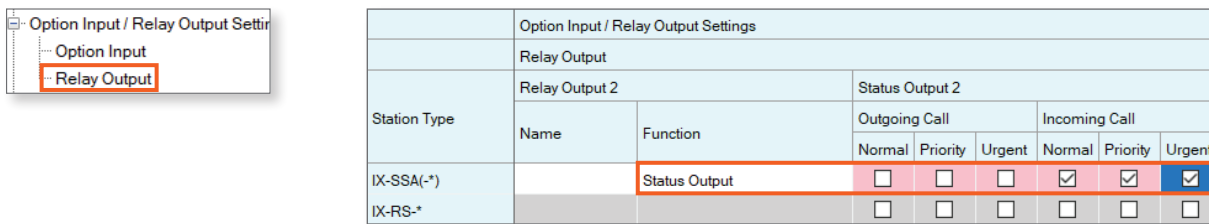

The screenshot shows the 'Option Input / Relay Output Settings' window with 'Relay Output' selected. The main table displays the configuration for 'Relay Output 2':

Station Type	Name	Function	Status Output 2					
			Outgoing Call			Incoming Call		
			Normal	Priority	Urgent	Normal	Priority	Urgent
IX-SSA(-*)		Status Output	<input type="checkbox"/>	<input type="checkbox"/>	<input type="checkbox"/>	<input checked="" type="checkbox"/>	<input checked="" type="checkbox"/>	<input checked="" type="checkbox"/>
IX-RS-*			<input type="checkbox"/>	<input type="checkbox"/>	<input type="checkbox"/>	<input type="checkbox"/>	<input type="checkbox"/>	<input type="checkbox"/>

Enabling Door Release by IX-RS

Navigate to **Station Settings**, Door Release Assignment. Scroll all the way to the right and set the drop-down menu under Door Release by IX-RS to **Enable**. Click **Update**.

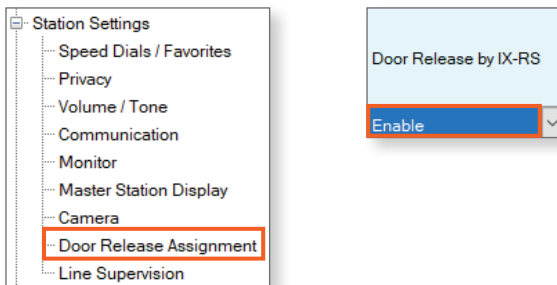

The screenshot shows the 'Station Settings' window with 'Door Release Assignment' selected. The 'Door Release by IX-RS' dropdown menu is set to 'Enable'.

Navigate to **File**, Upload Settings to Station. Select all stations and click **Settings**.

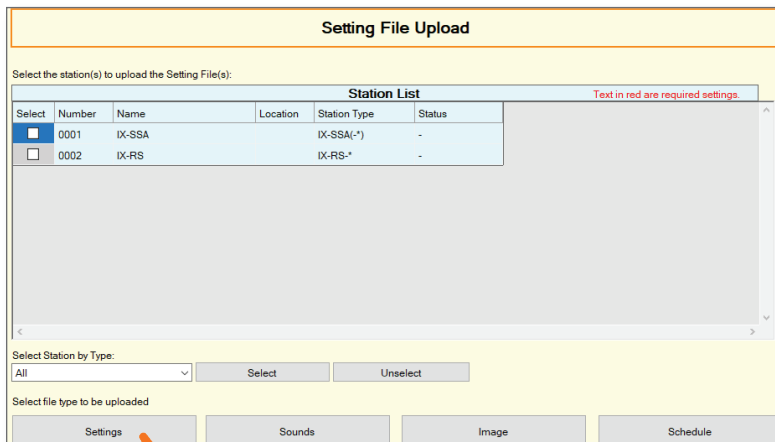

The screenshot shows the 'Setting File Upload' dialog box. The 'Station List' table is visible:

Select	Number	Name	Location	Station Type	Status
<input checked="" type="checkbox"/>	0001	IX-SSA		IX-SSA(-*)	-
<input type="checkbox"/>	0002	IX-RS		IX-RS-*	-

At the bottom, the 'Select file type to be uploaded' section has 'Settings' selected, indicated by an orange hand icon.

Wiring the Door Station Relays for Auto Answer

Once the door station's input and output have been configured, the programmed relays will need to be connected.

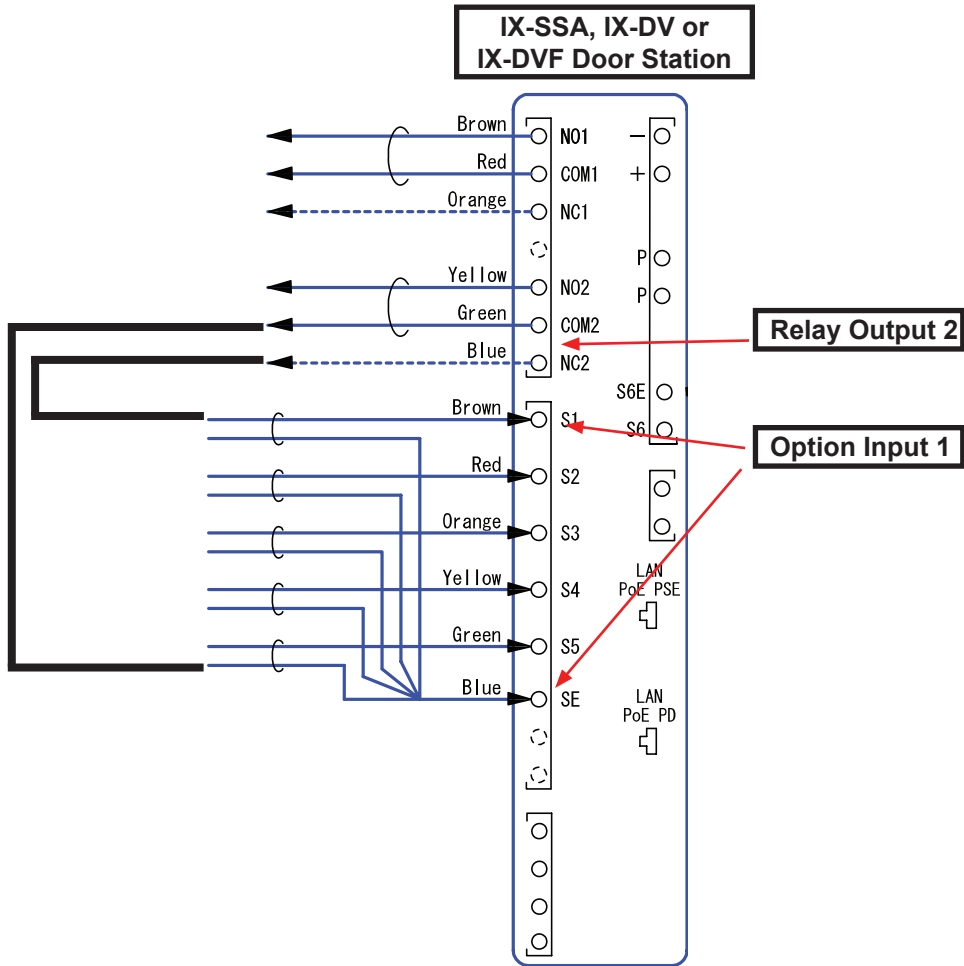

i Both the input and output wires are nonpolar, so the colored wires can be reversed.